

OWNERS MANUAL

89DF HIMTLC PLUS

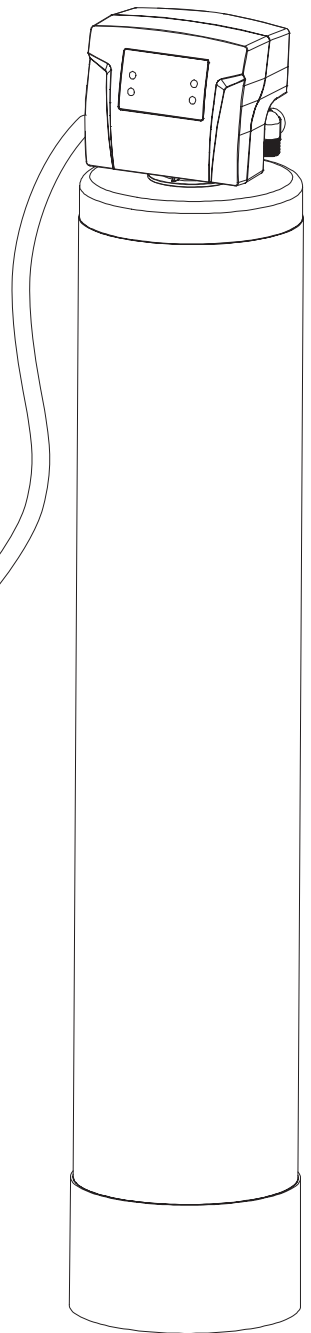
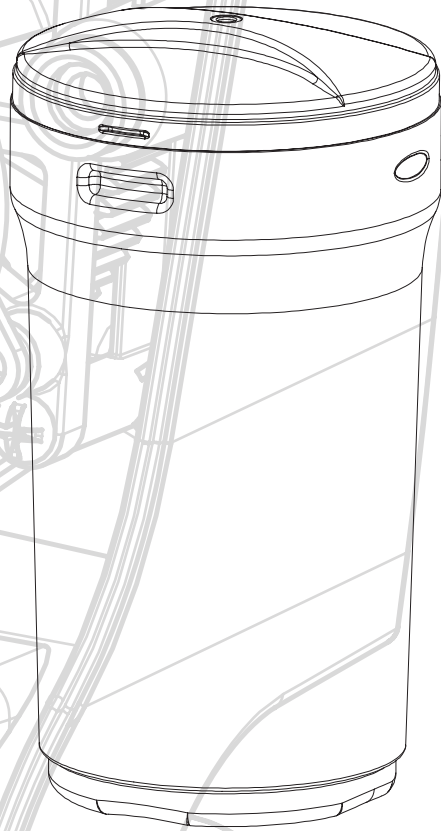

NOTE: This media solution is not designed for lake water/ open water sources, except where the source water has been pre-treated by chlorine and de-chlorinated. Organics in open water sources will foul this media. It should only be applied to well water.

1. Read all instructions carefully before operation.
2. Avoid pinched o-rings during installation by applying (provided with install kit) NSF certified lubricant to all seals.
3. This system is not intended for treating water that is microbiologically unsafe or of unknown quality without adequate disinfection before or after the system.

Canada West

855 Park St., Unit 1
Regina, SK S4N 6M1

7503 35th St. SE
Calgary, AB T2C 1V3

Canada East

490 Pinebush Rd., Unit 1
Cambridge, ON N1T 0A5

U.S.A.

7229 University Avenue, NE
Fridley, MN 55432

9760 Mayflower Park Drive
Suite 110
Carmel, IN 46032

4655 McDowell Rd. W
Phoenix, AZ 85035

56 Lightcap Road
Pottstown, PA 19464

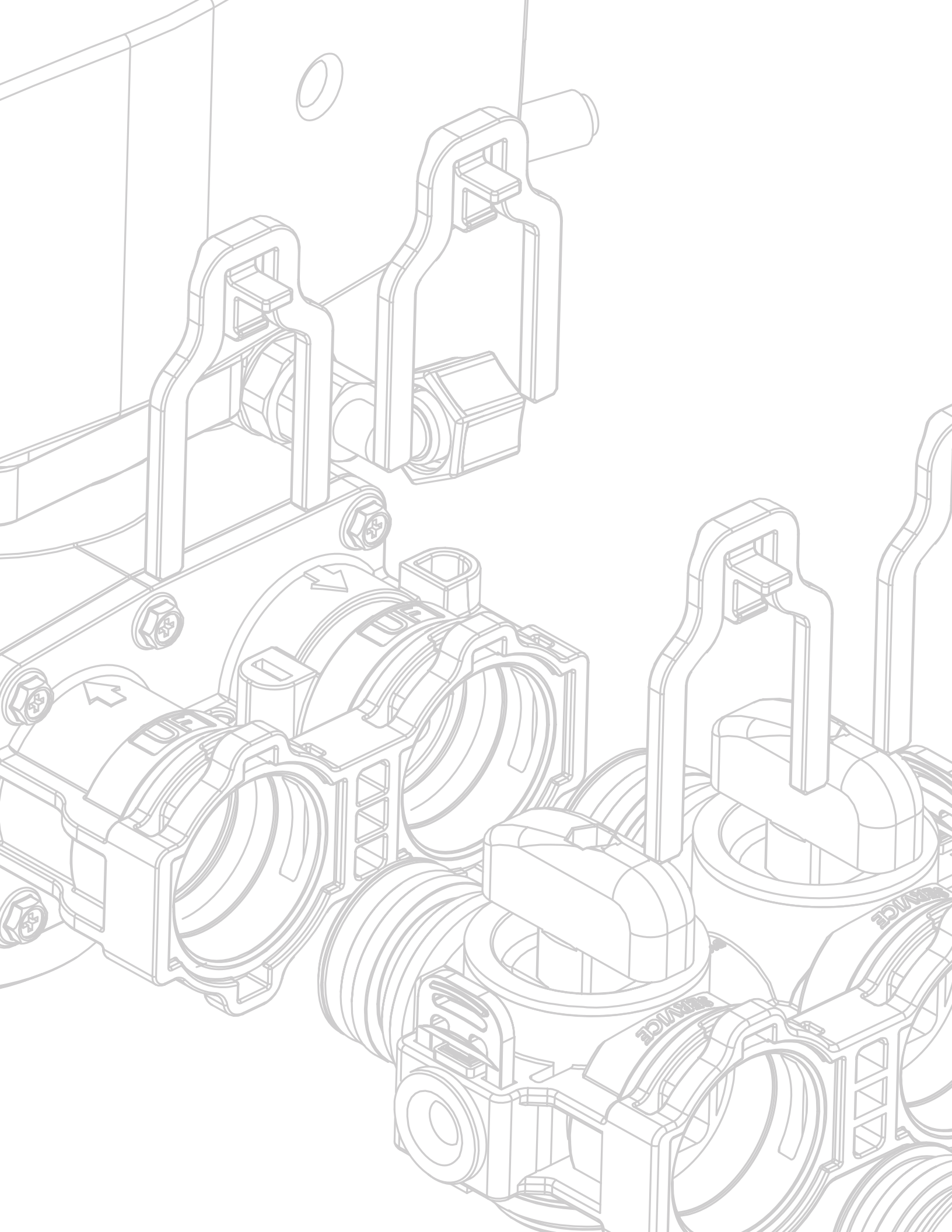

Table of Contents

READ THIS MANUAL FIRST	4
SPECIFICATION/SYSTEM DIMENSIONS/HOW A SPECIALTY SYSTEM WORKS	5
UNPACKING/INSPECTION OF TWIN TANK MODEL	6
BEFORE INSTALLATION	9
INSTALLATION STEPS/PREPARATIONS	11
STARTUP INSTRUCTIONS	15
SYSTEM CHECK LIST/DURING REGENERATION/PLUMBING SYSTEM CLEAN-UP	17
WATER BYPASS/OPERATING CONDITIONS	18
SERVICING 89 VALVE	19
TIMER REPLACEMENT/PISTON AND/OR BRINE VALVE ASSEMBLY REPLACEMENT	20
METER ASSEMBLY REPLACEMENT/CLEAN INJECTOR ASSEMBLY	21
METER ASSEMBLY REPLACEMENT/REPLACE MOTOR/REPLACE MICROSWITCHES	22
CIRCUIT BOARD REPLACEMENT/AFTER SERVICING	23
PARTS BREAKDOWN	24
TROUBLE SHOOTING GUIDE	29
MASTER PROGRAMMING GUIDE	30
MAIN MENU 89 DOWNFLOW	33
DIAGNOSTIC SCREEN	34
WARRANTY	48

READ THIS MANUAL FIRST

NOTE: This media solution is not designed for lake water/ open water sources, except where the source water has been pre-treated by chlorine and de-chlorinated. Organics in open water sources will foul this media. It should only be applied to well water.

- ▶ This system must be put into one complete regeneration cycle upon installation. The media bed has self leveling properties and must be regenerated upon installation in order to work correctly.
- ▶ Read this manual thoroughly to become familiar with the device and its capabilities before installing or operating your Specialty System. Failure to follow instructions in this manual could result in personal injury or property damage. This manual will also help you to get the most out of your Softener.
- ▶ This system and its installation must comply with state and local regulations. Check with your local public works department for plumbing and sanitation codes. In the event the codes conflict with any content in this manual the local codes should be followed. For installations in Massachusetts, Massachusetts Plumbing Code 248 CMR shall be adhered to. Consult your licensed plumber for installation of this system.
- ▶ This Specialty System is designed to operate on pressures of 30 psi to 125 psi. If the water pressure is higher than the maximum use a pressure reducing valve in the water supply line to the Softener.
- ▶ This unit is capable of operating at temperatures between 40°F and 110°F (4°C - 43°C). Do not use this Specialty System on hot water supplies.
- ▶ Do not install this unit where it may be exposed to wet weather, direct sunlight, or temperatures outside of the range specified above.
- ▶ Avoid pinched o-rings during installation by applying (provided with install kit) NSF certified lubricant to all seals.
- ▶ These systems are commonly exposed to high levels of iron, manganese, sulfur, and sediments. Damage to pistons, seals, and or spacers within the control valve are not covered in this warranty due to the harsh environment.
- ▶ It is recommended to regularly inspect and service the control valve on an annual basis. Cleaning and or replacement of piston, seals, and or spacers may be necessary depending on how harsh the conditions are. An Annual Maintenance kit (Part # 60010307) is available for this purpose
- ▶ Do not use water that is microbiologically unsafe without adequate disinfection before or after this system.
- ▶ This publication is based on information available when approved for printing. Continuing design refinement could cause changes that may not be included in this publication. Canature WaterGroup™ reserves the right to change the specifications referred to in this literature at any time, without prior notice.

Safety Messages

Watch for the following safety messages in this manual:

NOTE: used to emphasize installation, operation or maintenance information which is important but does not present a hazard.

Example: NOTE: Check and comply with you state and local codes. You must follow these guidelines.

CAUTION: used when failure to follow directions could result in damage to equipment or property.

Example:



CAUTION! Disassembly while under pressure can result in flooding.

WARNING: used to indicate a hazard which could cause injury or death if ignored.

Example:

WARNING! ELECTRICAL SHOCK HAZARD! UNPLUG THE UNIT BEFORE REMOVING THE COVER OR ACCESSING ANY INTERNAL CONTROL PARTS

NOTE: Do not remove or destroy the serial number. It must be referenced on request for warranty repair or replacement



SPECIFICATION

Specifications	HIMTLC PLUS -150	HIMTLC PLUS -200	HIMTLC PLUS -250	HIMTLC PLUS -300
Salt Used - Per Regeneration	9.0 lbs	12.0 lbs	15.0 lbs	18.0 lbs
Water Used - Regeneration	74.6 ga l	98.9 ga l	126.6 ga l	153.0 ga l
Hardness Removal- Grains	17,100	22,800	28,500	34,200
Advanced Exchange Media (ft3)	1.32ft3	1.76 ft3	2.20 ift3	2.64 ft3
Tank Size	10x54	12x52	13x54	14x65
Top Cone	Yes	Yes	Yes	Yes
Tank Jacket / Media Loaded	Yes	No	No	No
Brine Tank (Inches)	20.3 x 37.4	20.3 x 37.4	20.3 x 37.4	23.0 x 40.5
Salt Storage Capacity	350 lbs	350 lbs	350 lbs	420 lbs
Critical Service Flow Rate	4-6 gpm	6-8 gpm	8- 0 gpm	10-12 gpm
Back Wash Flow Rate	2.4 gpm	4.0 gpm	5.0 gpm	7.0 gpm
Shipping Weight	141lbs	158 lbs	198 lbs	244 lbs
Hardness	Maximum 45 gpg			
Iron	Maximum 15 ppm			
Manganese	Maximum 3 ppm			
Tannins	Maximum 5 ppm/ TOC17 ppm			
Ammonium	Maximum 4 ppm			
pH	5-9			
Other	Free Chlorine < 1ppm, TOS < 4000 ppm			
Regeneration Type	Down Flow			
Plumbing Connections	Includes 3/4" 90° Elbows & 1" Straight NPT			
Electrical Requirements	Input 120V 60 Hz - Output 12V 650mA			
Water Temperature	Min 39 - Max. 100°F			
Water Pressure	Min. 20 - Max. 125 psi			

Working Temperature = 34-110°F (1-43°C)
 (Do not subject the unit to freezing temperatures)
 Working Pressure = 30-125 PSIG (137-861 kPa)
 Voltage = 120V / 60 Hz
 Pipe Size = 3/4" or 1"

- At the stated service flow rates, the pressure drop through these devices will not exceed 15 psig.
- Changing salt settings from factory setting may require changing injector sizes to achieve stated capacities
- The manufacturer reserves the right to make product improvements which may deviate from the specifications and descriptions stated herein, without obligation to change previously manufactured products or to note the change.

* Do not use water that is microbiologically unsafe without adequate disinfection before or after the system.

SYSTEM DIMENSIONS

Models	A (Inches)	B (Inches)	C (Inches)
150	63"	10"	15"
200	61"	12"	16"
300	63"	13"	17"

Twin Tank Model

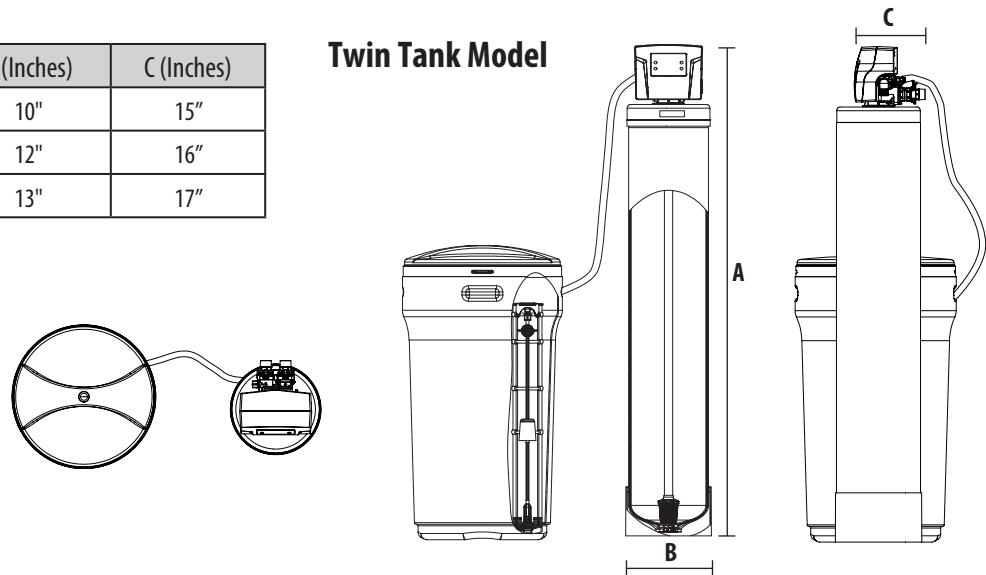

HOW A SPECIALTY SYSTEM WORKS

The multilayer media of this Specialty System is a single solution for Hardness, Iron, Manganese, Tannins and Ammonium. The media gets regenerated using salt when the capacity depletes.

UNPACKING / INSPECTION OF TWIN TANK MODEL

Be sure to check the entire unit for any shipping damage or parts loss. Also note damage to the shipping cartons. Contact the transportation company for all damage and loss claims. The manufacturer is not responsible for damages in transit.

Small parts, needed to install the Softener, are in a parts box. To avoid loss of the small parts, keep them in the parts bag until you are ready to use them.

What is included in the box?

For Models 75,10,15,20, you will expect the following:

1. Control Valve
2. Tank
3. Parts Box
4. Owners Manual
5. Drain Hose & Clamp (Not included in some brands)
6. Brine Tank Assembly

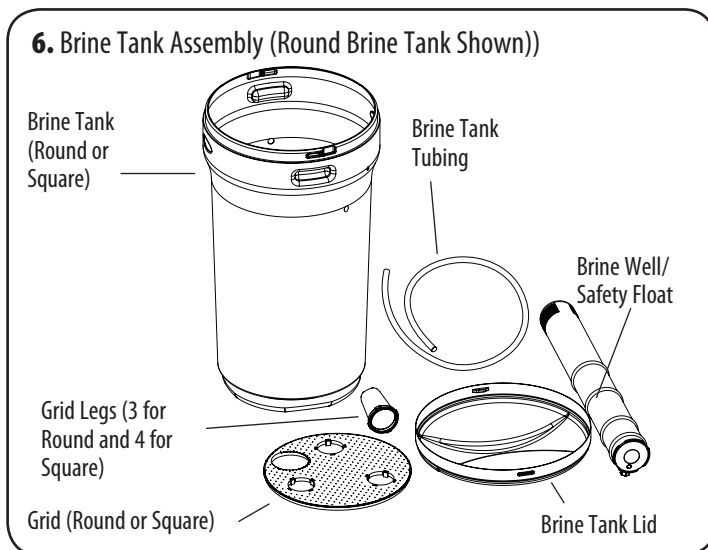
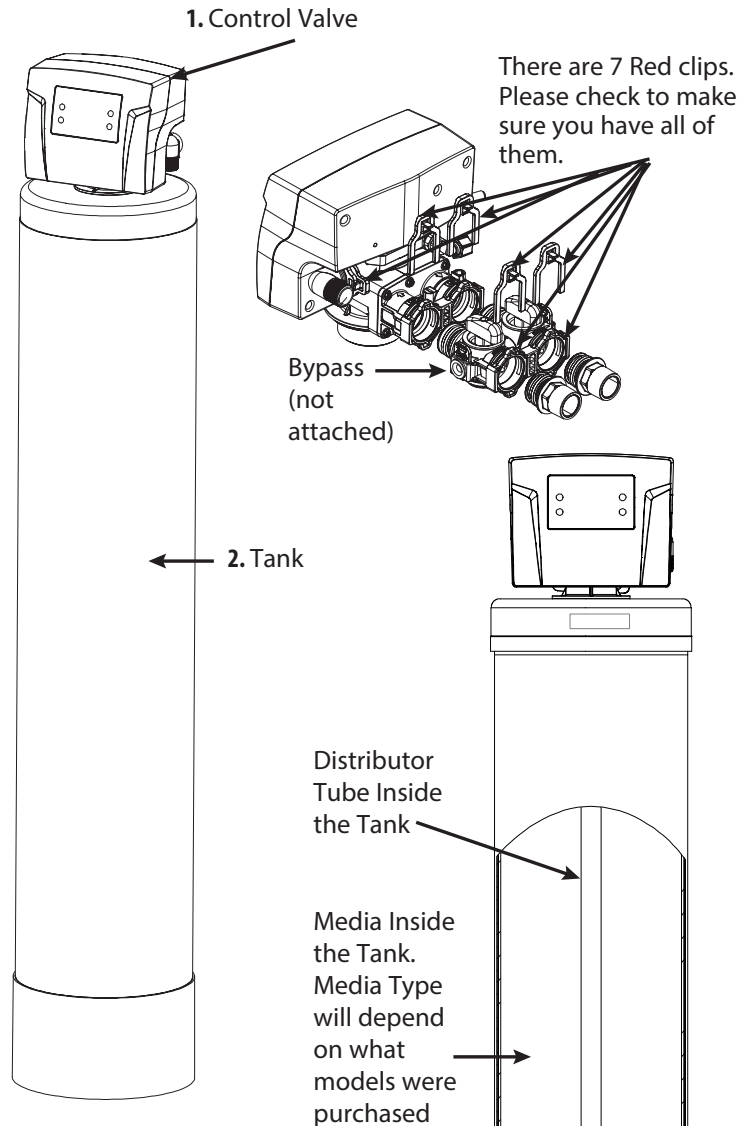
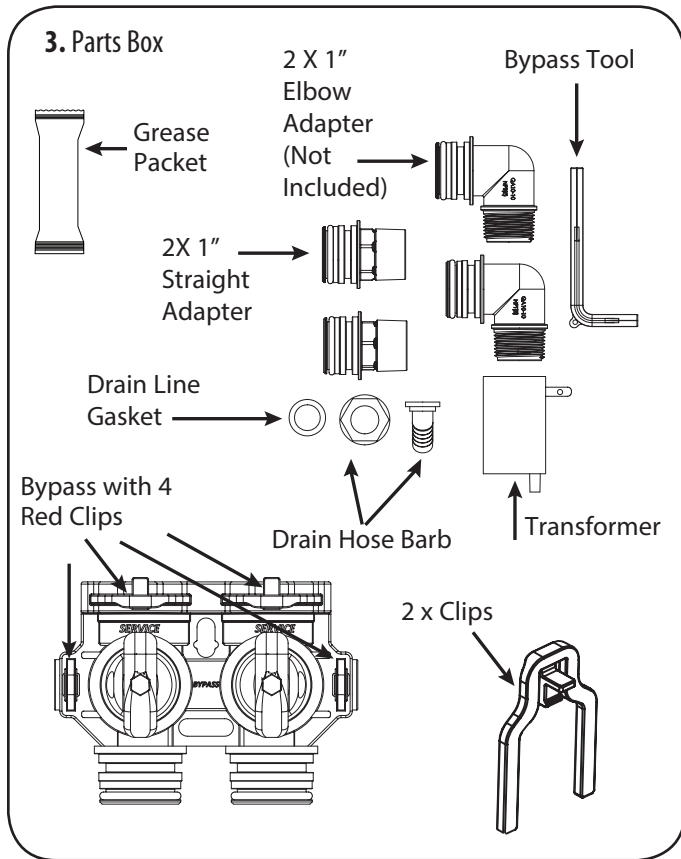

For Models 200, 250 and 300 the media and Control Valve is packaged separately in carton and bags

What is included with 200 and 250 models?

1. Tank (Models 200 and 250 will get an Adapter and Oring attached to the tank)
2. Control Valve with Parts Box
3. Media Boxes (Qty 3 for 200 and Qty 4 for 250)
4. Drain Line and Hose Clamp (Not Included with some models)
5. Brine Tank Assembly

Models 200, 250 will get Adaptor and Oring Shown

2. Control Valve

There are 7 Red clips. Please check to make sure you have all of them.

Bypass (not attached)

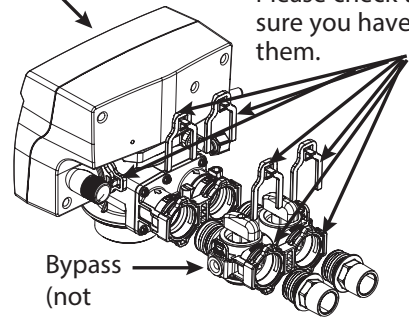

1. Tank

Distributor Tube Inside the Tank

Media Inside the Tank. Media Type will depend on what models were purchased

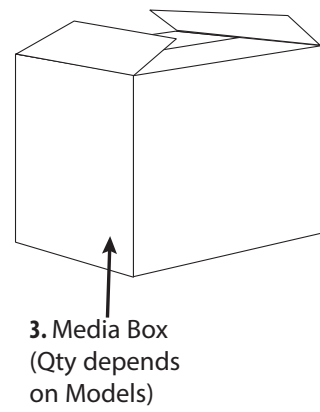
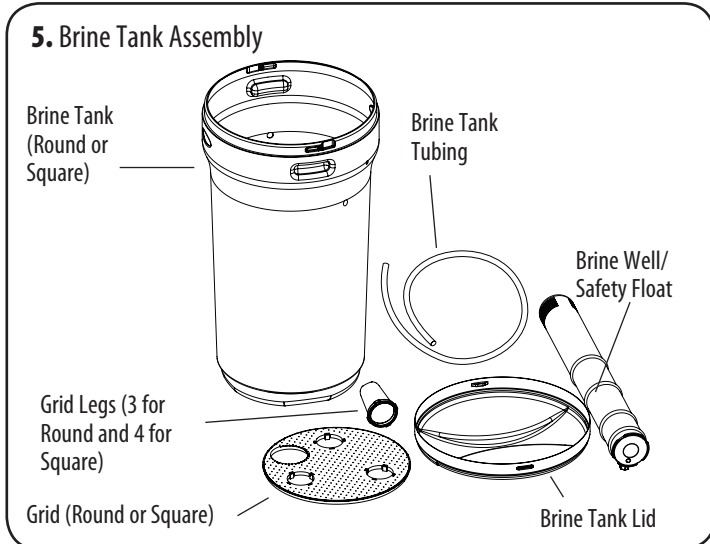
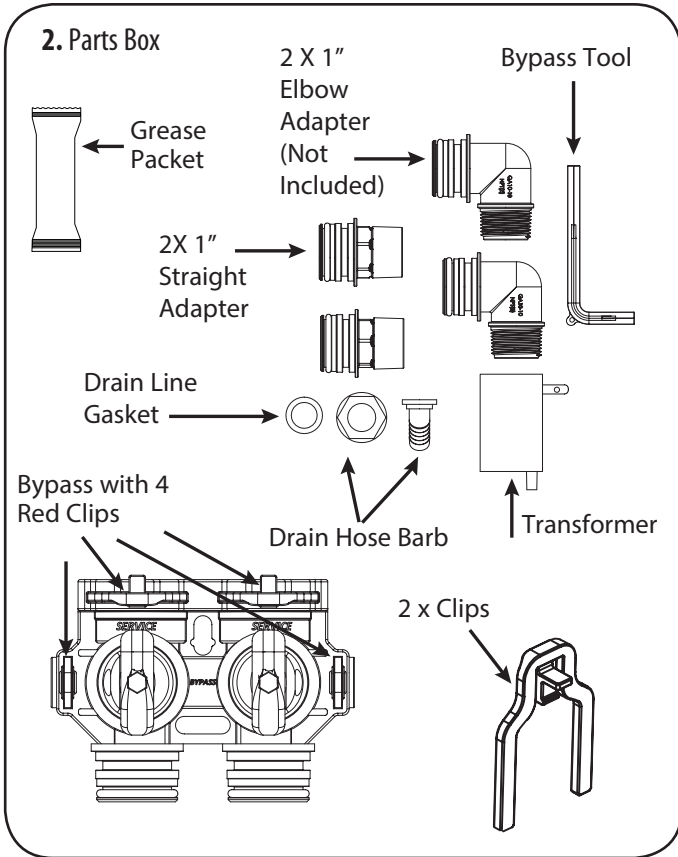
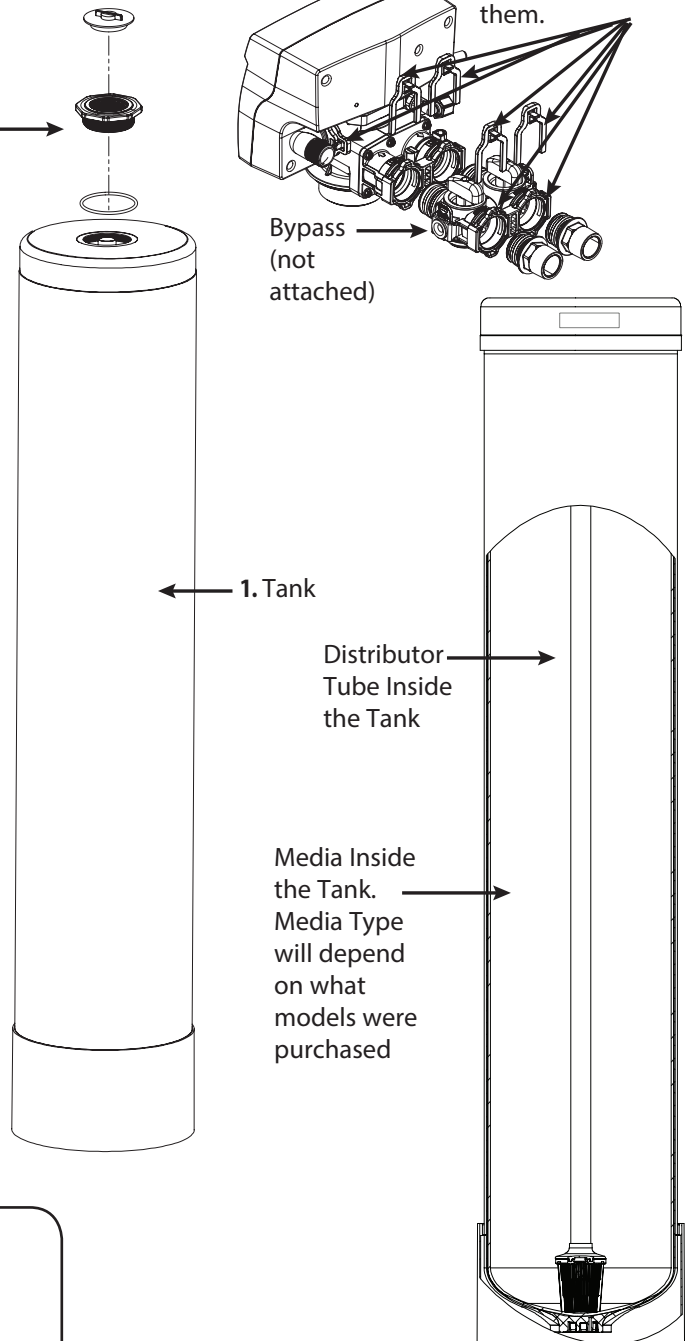

Check Valve Type and Valve Serial

Check to make sure the valve type is what you ordered. The serial # label on the left will show 890 (DF) for downflow valve and 890 (UF) for Upflow valve The right Sticker shows the serial # of the control valve. The middle Sticker is dataplate which provides information of Serial # and Date of Manufacture of complete system. Both Serial # labels are important for troubleshooting.

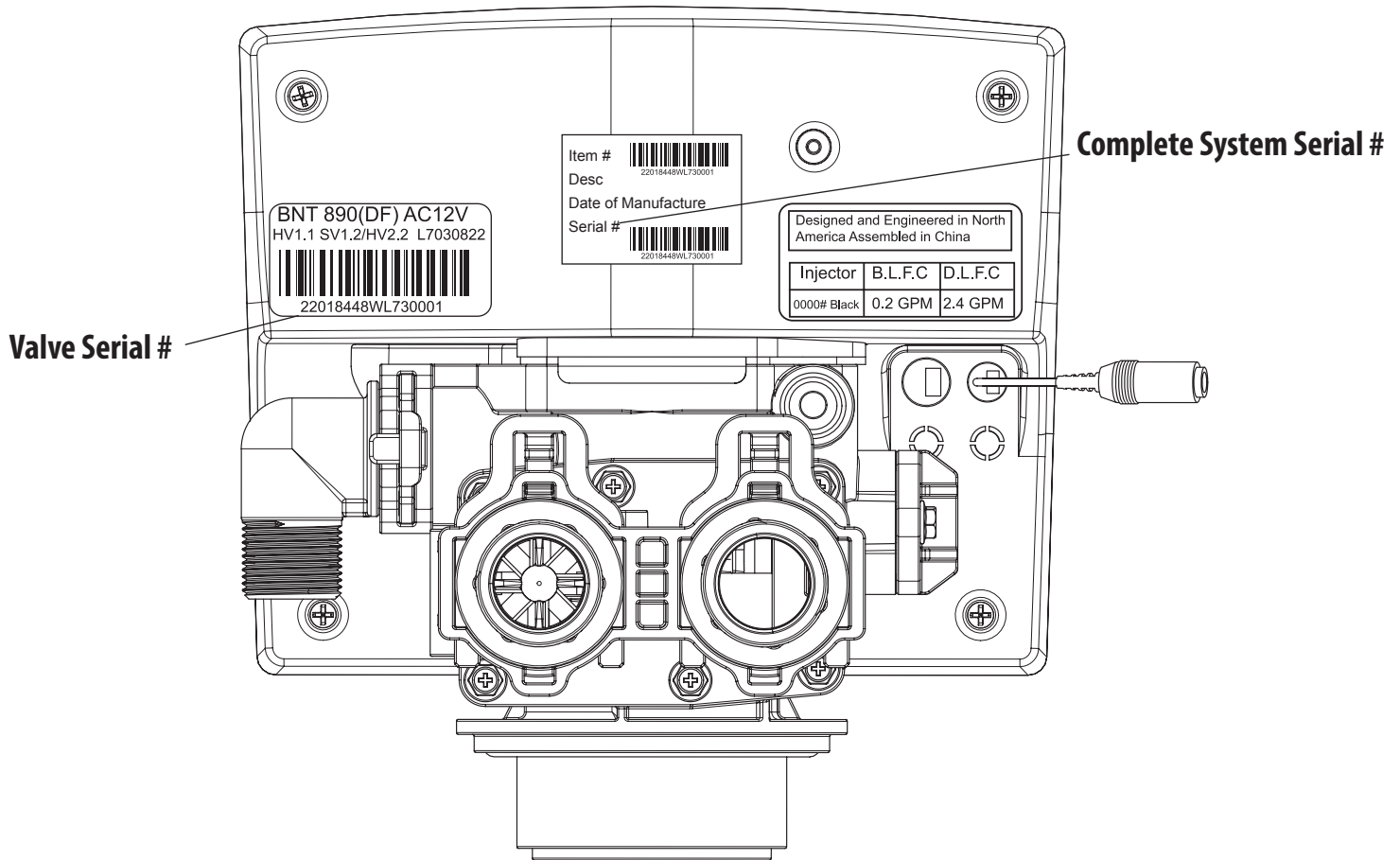

Valve Serial #:

22018448WL730001

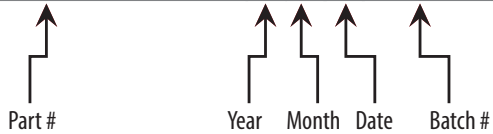

(22018448W): Part #

(L)Year: "M" stand for 2016 year, "L" stand for 2015, "K" stand for 2014, "J" stand for 2013

(7)Month: 1 (Jan) 2(Feb) 3(Mar) 4(April) 5(May) 6(June) 7(July) 8(Aug) 9(Sep) A(Oct) B(Nov) C(Dec)

(3)Date: 1 2 3 4 5 6 7 8 9 A(10) B(11) C(12) D(13) E(14) F(15) G(16) H(17) I(18) J(19) K(20) L(21) M(22) N(23) O(24) P(25) Q(26) R(27) S(28) T(29) U(30) V(31)

(0001): Batch code

BEFORE INSTALLATION

Contact your local distributor to use Canature WaterGroup™ laboratory for complete water analysis free of cost and no obligation to you.

The laboratory addresses can be found on the front page of the manual.

Check your water hardness. Use test strips (Part # 2793828-20) to get an estimation of water hardness and contact your local distributor to use Canature WaterGroup laboratory for complete water analysis free of cost and no obligation to you.

All government codes and regulations governing the installation of these devices must be observed.



If the ground from the electrical panel or breaker box to the water meter or underground copper pipe is tied to the copper water lines and these lines are cut during installation of the Noryl bypass valve and/or poly pipe, an approved grounding strap must be used between the two lines that have been cut in order to maintain continuity. The length of the grounding strap will depend upon the number of units being installed and/or the amount of copper pipe being replaced with plastic pipe. See below.

In all cases where metal pipe was originally used and is later interrupted by poly pipe or the Noryl bypass valve or by physical separation, an approved ground clamp with no less than #6 copper conductor must be used for continuity, to maintain proper metallic pipe bonding.

NOTE: Check your local electrical code for the correct clamp.

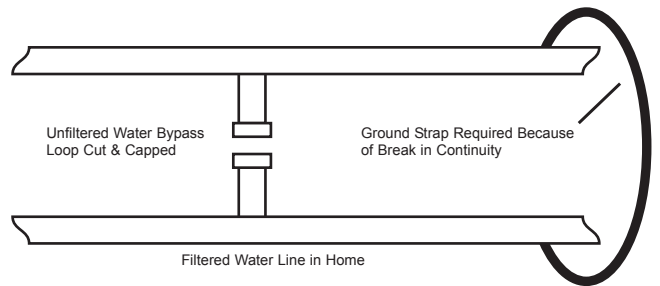
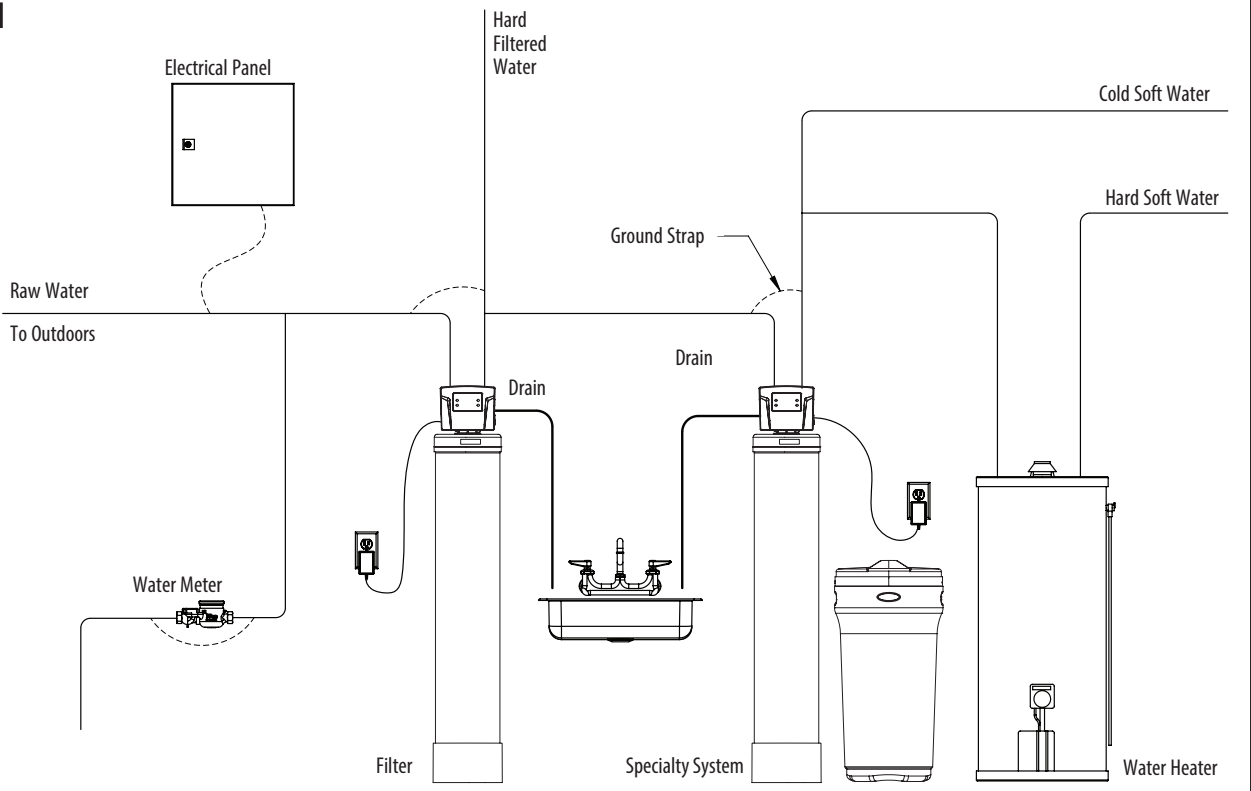

Figure 1



Inspecting and Handling Your 89 Specialty System

Inspect the equipment for any shipping damage. If damaged, notify the transportation company and request a damage inspection. Damage to cartons should also be noted.

Handle the Softener unit with care. Damage can result if it is dropped or set on sharp, uneven projections on the floor.

Do not turn the Softener unit upside down.

NOTE: If a severe loss in water pressure is observed when the Specialty System is initially placed in service, the Specialty System tank may have been laid on its side during transit. If this occurs, backwash the Specialty System to "reclassify" the media.

Check Your Water Pressure and Pumping Rate

Two water system conditions must be checked carefully to avoid unsatisfactory operation or equipment damage:

1. Minimum water pressure required at the Softener tank inlet is 30 psi.
2. The pumping rate of your well pump must at least equal the required backwash flow rate of your model (see Specifications on Page 5 for backwash flow rates).

To measure the pumping rate of your pump, follow these instructions:

- a. Make certain no water is being drawn. Open spigot nearest pressure tank. When pump starts, close spigot and measure time (in seconds) to refill pressure tank (when pump shuts off). This figure represents cycle time.
- b. With the pressure tank full, draw water into a container of known volume and measure the number of gallons drawn until the pump starts again. This is draw-down. Divide this figure by cycle time and multiply the result by 60 to arrive at the pumping rate in gallons per minute (gpm).

To aid in your calculation, insert the data in the following formula:

$$\text{DRAWDOWN} \frac{\text{_____}}{\text{(gals)}} \div \text{CYCLE TIME} \frac{\text{_____}}{\text{(seconds)}} \times 60 \\ = \text{PUMPING RATE} \frac{\text{_____}}{\text{(gpm)}}$$

EXAMPLE: DRAWDOWN is 6 gals; CYCLE TIME is 53 secs; then, PUMPING RATE equals:
 $6 \text{ gals} \div 53 \text{ secs} \times 60 = 6.8 \text{ gpm}$

See Specifications on page 5 for minimum flow rates.

NOTE: If the plumbing system is used as the ground leg of the electric supply, continuity should be maintained by installing ground straps around any nonconductive plastic piping used in installation.

Tools Required for Installation:

- ▶ Two adjustable wrenches
- ▶ Additional tools may be required if modification to home plumbing is required.
- ▶ Plastic inlet and outlet fittings are included with the softener. To maintain full valve flow, 3/4" or 1" pipes to and from the softener fittings are recommended. You should maintain the same, or larger, pipe size as the water supply pipe, up to the softener inlet and outlet.
- ▶ Use copper, brass, or PEX pipe and fittings.
- ▶ Some codes may also allow PVC plastic pipe.
- ▶ ALWAYS install the included bypass valve, or 3 shut-off valves. Bypass valves let you turn off water to the Softener for repairs if needed, but still have water in the house pipes.
- ▶ 5/8" OD drain line is needed for the valve drain. A 10' length of hose is not included with some brands.

Locate Water Conditioning Equipment Correctly

Select the location of your Softener tank with care. Various conditions which contribute to proper location are as follows:

1. Locate as close as possible to the water supply source.
2. Locate as close as possible to a floor or laundry tub drain.
3. Locate in correct relationship to other water conditioning equipment (see Fig. 1).
4. Softener should be located in the supply line before the water heater. Temperatures above 120°F damage softeners.
5. Do not install a softener in a location where freezing temperatures occur. Freezing may cause permanent damage to this type of equipment and will void the factory warranty.
6. Allow sufficient space around the unit for easy servicing.
7. If your water source is a community water supply, a public water supply or you wish to bypass water used for a geothermal heat pump, lawn sprinkling, out-buildings or other high demand applications, refer to Fig. 1.
8. Keep the softener out of direct sunlight. The sun's heat may soften and distort plastic parts.

INSTALLATION STEPS

Determine the best location for your Specialty System, bearing in mind the location of your water supply lines, drain line and 120 volt AC electrical outlet. Subjecting the Softener to freezing or temperatures above 43°C (110°F) will void the warranty.

Please notice the inlet and outlet labels on the valve as shown here to determine the position of the equipment:

For DF Specialty System - The inlet should be on the left hand side of the valve and out on the right hand side

Downflow Valve

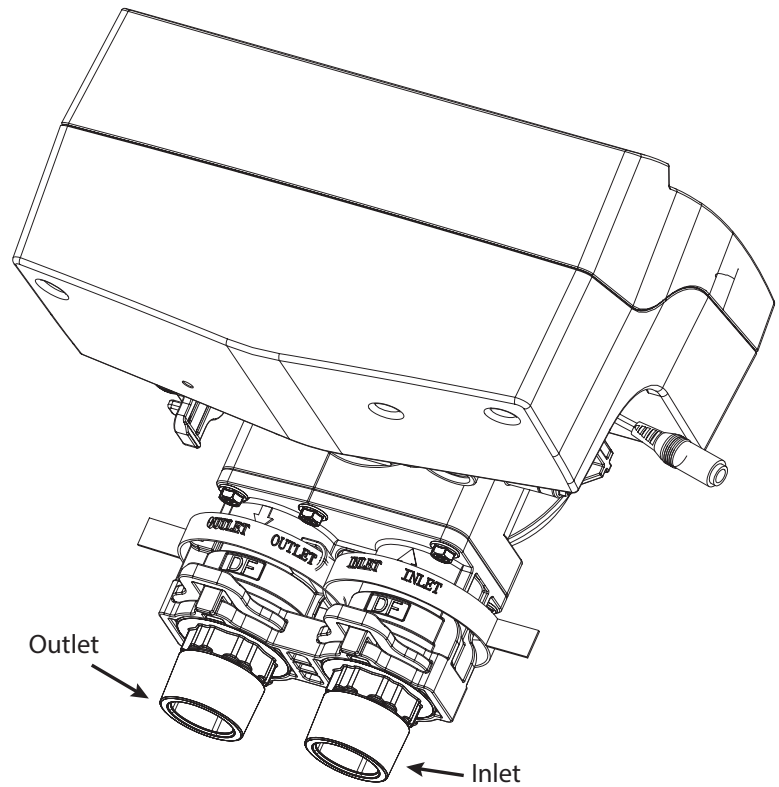

PREPARATIONS

- 1. Media Installation (When Necessary).** Models including and higher than 2 CF (Models 250,300) of media are shipped with separate media in pails or boxes. Models lower than 2 CF of media come loaded with media and this step can be skipped for new installation.



CAUTION! The unit should be de-pressurized before installing or replacing media

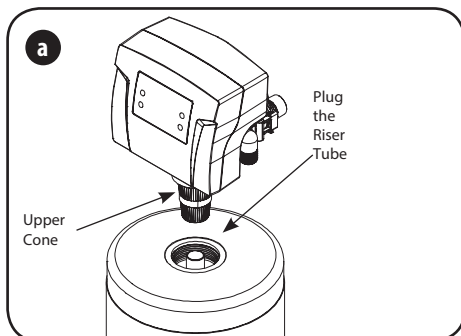

- a)** Lube the bottom oring (picture **d**) and attach the upper cone to the valve.

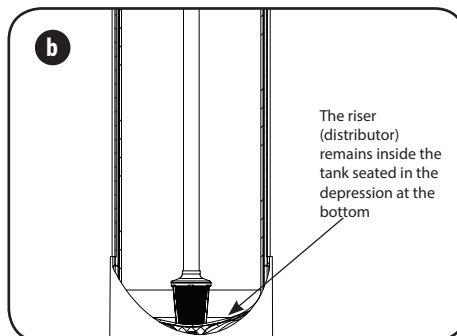

- b)** Temporarily plug the open end of the riser tube to ensure that no resin or gravel falls down into the distribution. The riser (distributor) remains inside the tank seated in the depression at the bottom.
- Plug tube with a tape. Remove after media is loaded.

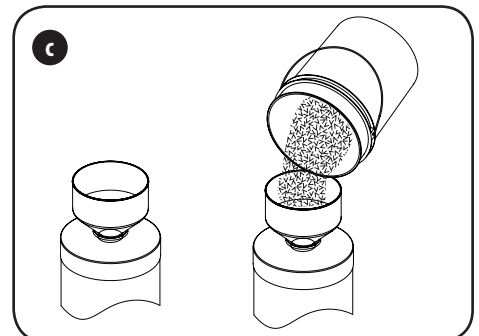

- c)** Fill support bed first.
- The media will not always spill down inside the tank and may need to be swept inside.
- The large funnel (sold separately makes filling the tank easier and neater. (Or an empty 1 gallon or 4 liter container with the bottom cut out makes a good funnel.)

PREPARATIONS

1. Media Installation (continued)

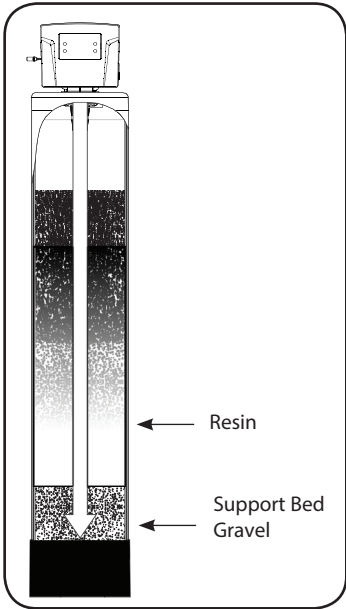

Fill tank one quarter full of water to protect distribution during gravel installation.

Place the media into the tank in the order indicated above. Slowly and carefully add the gravel support bed and the filtration media leveling each layer as it is placed into the tank.

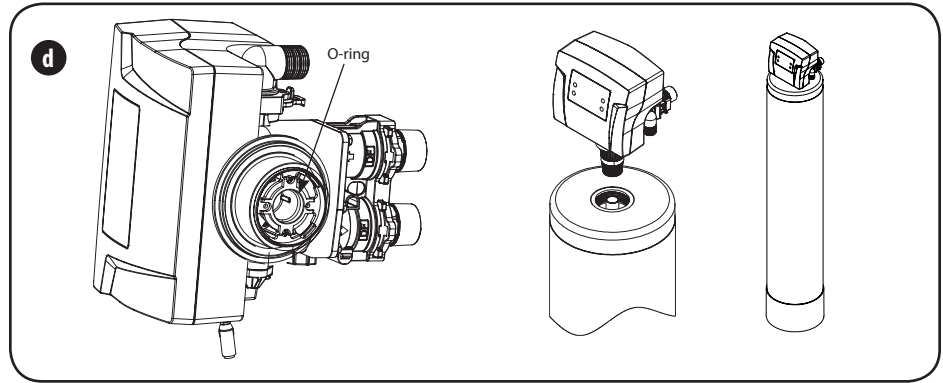

d) Unplug the riser tube, carefully position the valve over it and turn the valve into the threads in the fiberglass tank, tightening securely into tank. Note: Ensure that the internal O-ring in the valve fits securely over the riser tube. Silicone grease (part # 92360) or other food grade lubricant may be applied to the O-ring to ease installation of the riser tube.

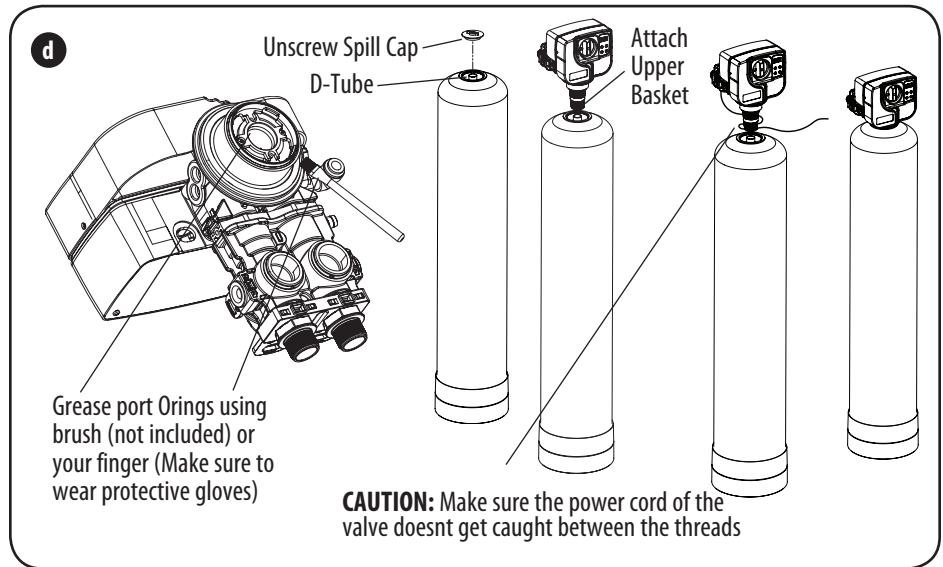

d) Lube the bottom Valve Orings with the grease supplied, Attach the Upper Basket. Unscrew the spill cap. Carefully Slide the D-Tube inside the Valve and Screw the Valve inside the Tank such that the power cord doesn't get caught between the valve and the tank.

NOTE: This media solution is not designed for lake water/ open water sources, except where the source water has been pre-treated by chlorine and de-chlorinated. Organics in open water sources will foul this media. It should only be applied to well water.



CAUTION: Make sure that the unit is de-pressurized before conducting this task.

DO NOT use petroleum based lubricants as they will cause swelling of O-ring seals.

2. Water Lines

Outside faucets used to water lawns and gardens should not supply softened water. A new water line is often required to be connected to supply hard water to the inlet of the Specialty System and to the outside faucets. Cut the water line between where it enters the house and before any lines that branch off to feed the hot water heater or other fixtures in the house and as near the desired location of the Specialty System as possible. Install a tee fitting on the feed end of the cut pipe, and an elbow fitting on the other end. Install piping from the tee to the inlet of the Specialty System and from the elbow to the outlet of the softener. To sever the water lines which branch off to feed any outside faucets, cut the branch lines approximately two inches from the fitting on the main water line. Install an elbow on the end of the pipe nearest the outside faucet and a cap on the end connected to the existing water line. Install piping from the tee installed on the inlet line to the Specialty System to the elbow installed on the pipe to the outside faucet. Following this procedure will result in all lines in the house, with the exception of the outside faucets, but including the water heater and therefore the hot water lines, being supplied with soft water.

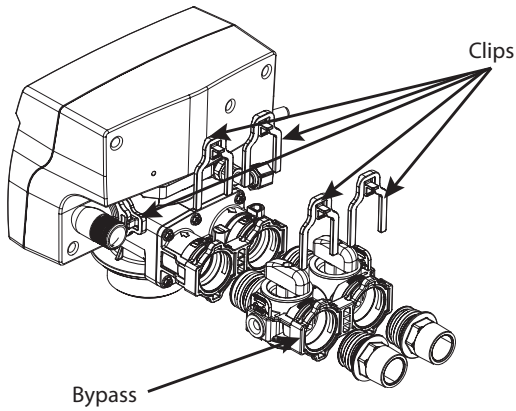

3. Attaching Bypass to Valve

Make sure the bypass is attached well to the control valve. Connect the straight or elbow connectors to the bypass with red clips. Connect the inlet and outlet of the Specialty System to the plumbing of the house. The control valve must not be submitted to temperatures above 43°C (110°F). When sweat fittings are used, to avoid damaging the control valve, solder the threaded copper adapters to the copper pipe and then, using Teflon tape, screw the assembly into the bypass valve.

Do not use pipe thread compound as it may attack the material in the valve body.

4. Drain Line Connection

Using Teflon tape, screw the 1/2" hose barb and attach oring into the drain port in the valve. Attach 1/2" drain hose (Supplied with some models and brands) to the hose barb and tighten securely with a hose clamp (Supplied with some models and brands).

Run the drain line to a floor drain or a laundry drain. Complete any necessary plumbing.

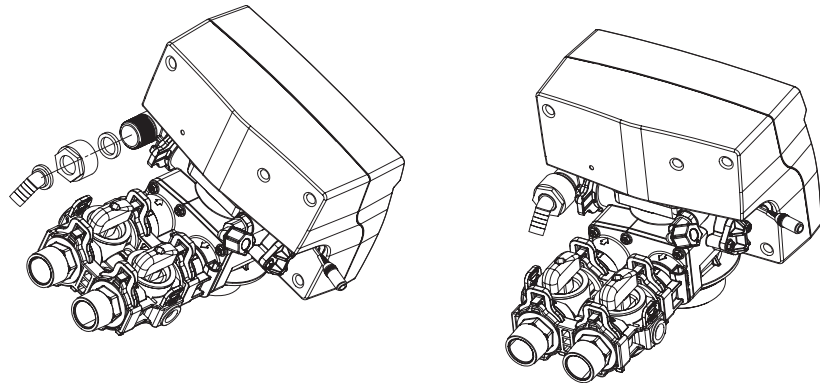

5. Assembling Brine Tank

a) Attach the three brine grid legs to grid plate. The legs will snap on to the tabs of the salt plate making a "click" sound. For square brine tank there are four legs.)

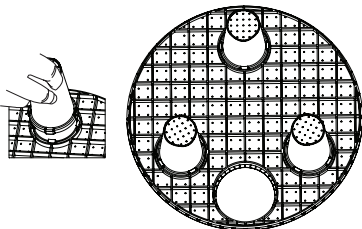

b) Insert the brine well assembly inside the grid plate as well below.

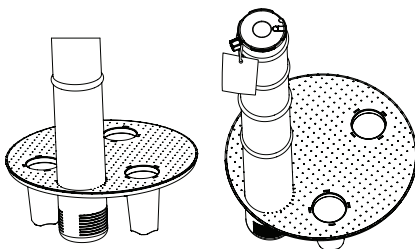

c) Drop the brine grid with brine well inside the brine tank such that the nut fitting faces the hole on the brine tank. Then press the grid evenly inside the brine tank until the brine grid legs touches the bottom of the brine tank.

IMPORTANT: IN ROUND BRINE TANK, IT IS IMPORTANT TO ALIGN THE HANDLE TO THE BRINE WELL AS SHOWN

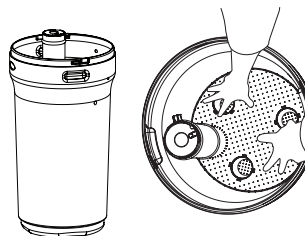

The hole in the brine tank should line up with the brine line as shown for round and square brine tank.

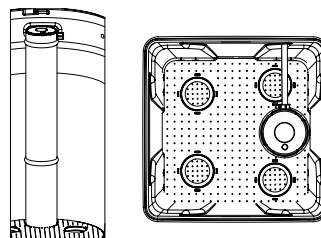

d) Take the brine tube and insert the nut and plastic sleeve as shown below.

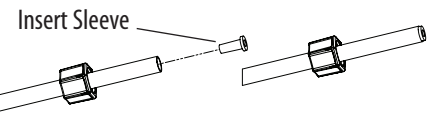

e) Insert the tube in the float assembly elbow and hand tighten the nut. In many cases the brine line already come installed from the factory. Leave the other end of the brine line tube inside the brine tank

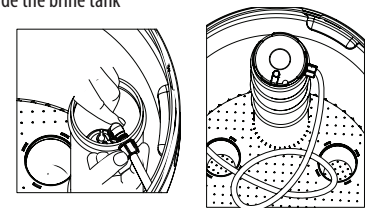

f) For installation of brine tank at the installation site, pull the other end of the brine tube from the hole on the brine tank. The completed assembly is shown below.

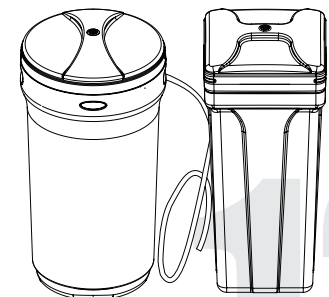

6. Attaching Brine Tubing to the Brine Line of the Valve

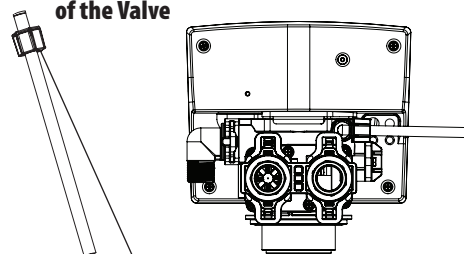

Insert Sleeve inside the Tubing

7. Connect Softener to the House Plumbing Any solder joints near the valve must be done before connecting any piping to the valve. Always leave at least 6" (152 mm) between the valve and joints when soldering pipes that are connected to the valve. Failure to do this could cause damage to the valve.

Downflow Specialty System Installation

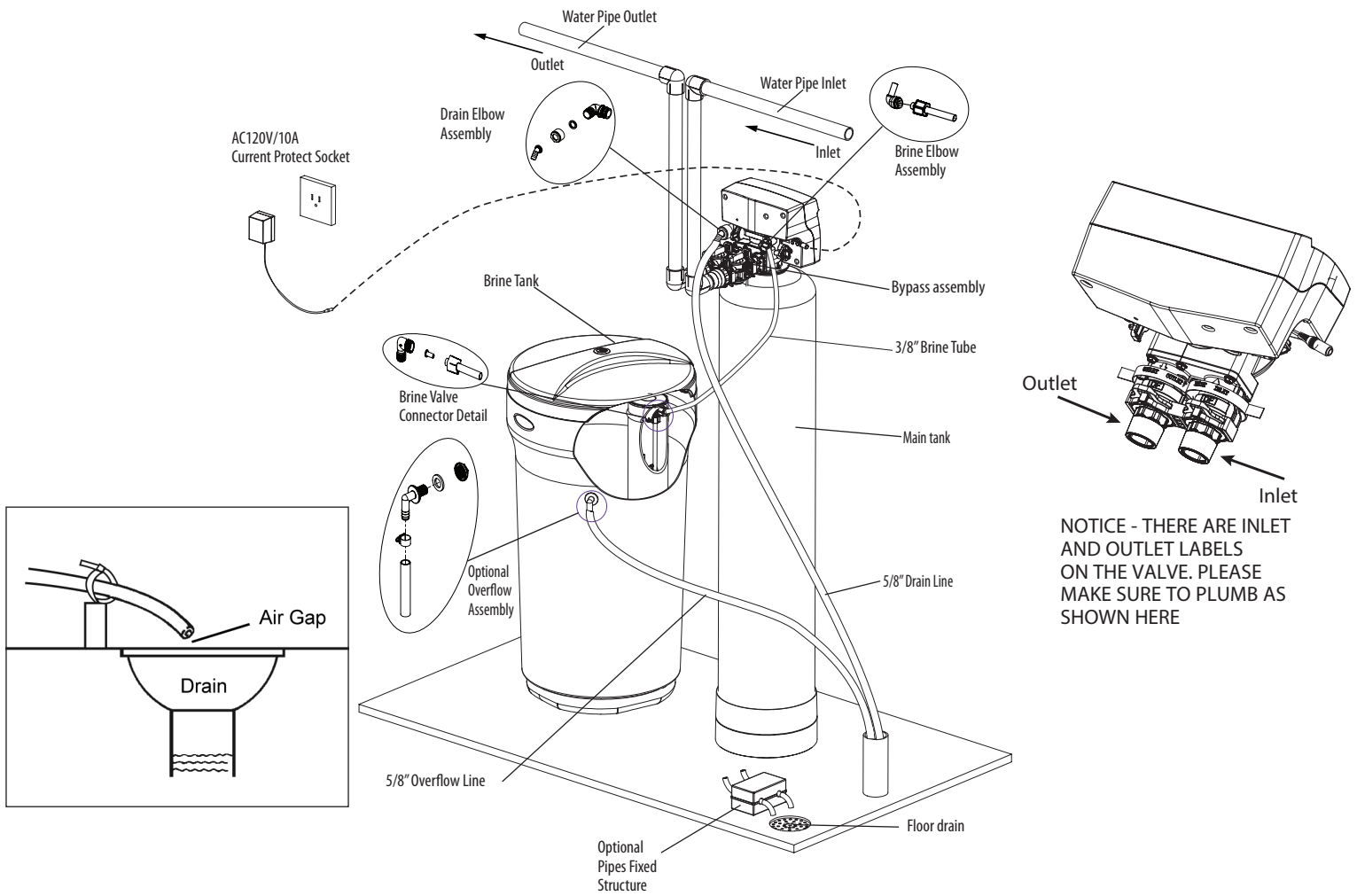
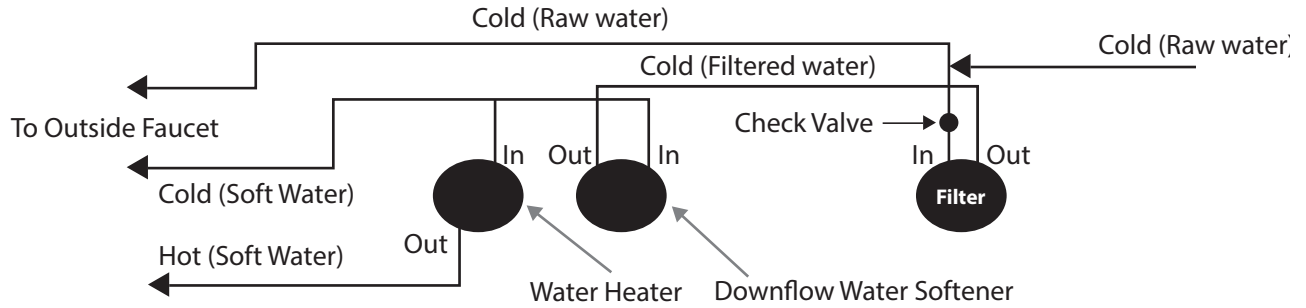

NOTICE - THERE ARE INLET AND OUTLET LABELS ON THE VALVE. PLEASE MAKE SURE TO PLUMB AS SHOWN HERE



Waste connections or drain outlet shall be designed and constructed to provide for connection to the sanitary waste system through an air-gap of 2 pipe diameters or 1 inch (22 mm) whichever is larger.



Never insert drain line directly into a drain, sewer line, or trap. Always allow an air gap between the drain line and the wastewater to prevent the possibility of sewage being back-siphoned into the conditioner.

STARTUP INSTRUCTIONS

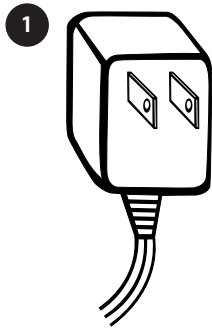
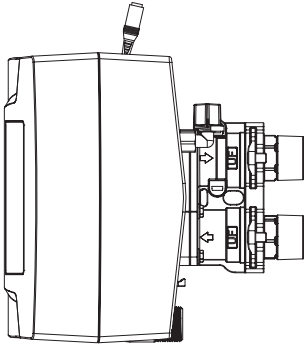

1. Connect the transformer to the valve. Plug the 12-volt transformer into a 120 VAC 60 Hz outlet.
2. Open the brine tank / cabinet salt lid and add water to the brine tank as per the chart below. Do not add salt to the brine tank at this time.
 - BTS-90:** 3 US Gallons
 - BTS-100:** 2.25 US Gallons
 - BTR-100:** 2.5 US Gallons
 - BTR-145:** 6 US Gallons

Familiarize with Button Configuration:

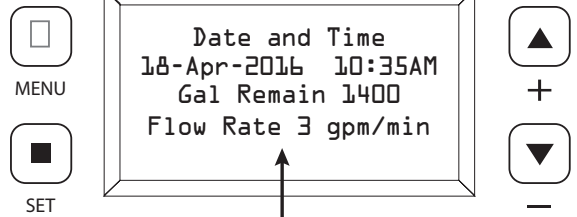



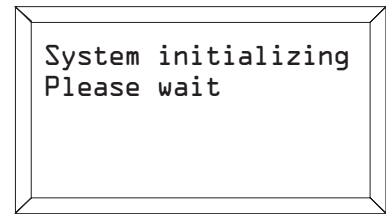

The controller will show the following on the screen - Time, Date and Gallons Remaining for Regeneration

3. When power is supplied to the control, the screen will display "INITIALIZING WAIT PLEASE" while it finds the service position.





Key Pad Configuration:

-  This function is to enter the basic set up information required at the time of installation.
-  This function is to accept the values if changed and advance to the next page in the menu.
-   These buttons are used to increase or decrease the value of the settings while in the programming mode.

4. Manually regenerate the valve. If screen is locked, press Menu Key  for 5 seconds to unlock.

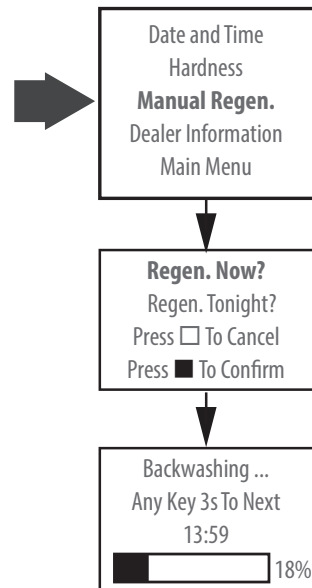
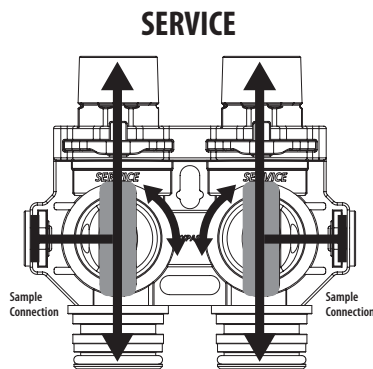

Manual Regeneration

Manually Regenerate the Valve and move it to backwash position. Press Menu Key  and Scroll down  using Up and Down Arrow buttons to "Manual Regen". Press "SET"  Select "Regen Now"



5. Please set up date and time of day and hardness. The Valve is already programmed from factory for Softener Models.

Set Up Current Time of Day and Regeneration Time When Softener Should Regenerate When No one uses Water in House.

Press Menu Key  and Select "Date and Time" using "Set"  button and set For setting the regeneration time, Press Menu Key  and Select Main Menu till you hear a beep and select Regen time

Set up Current Time of the Day and hardness:

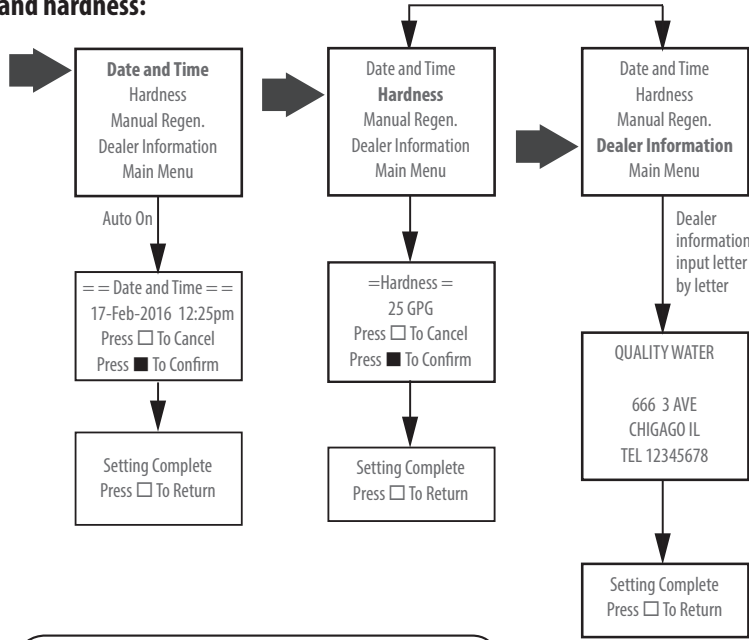

Set up Regeneration Time:

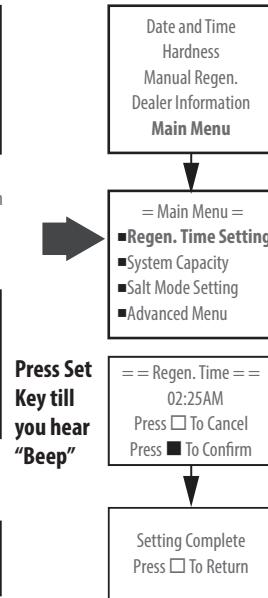

Soak Procedure:

1. Add 3-4 gallons of water to brine tank. (Be sure that salt level is above water level at all times)
2. Allow minimum 2 hours for the water to absorb the salt.
3. Start a manual regeneration.
4. Watch as the water level is decreased in the brine tank. When the water in the brine tank has been drawn into the mineral tank (10-15 minutes), unplug the valve.
5. Turn the bypass handles to the bypass mode.
6. Allow the unit to sit over night (8 hours). This allows a long contact time with the brine and media.
7. After 8 hours plug the power back in.
8. Turn the bypass handles to the service mode.
9. Allow the valve to complete its remaining portion of the regeneration.

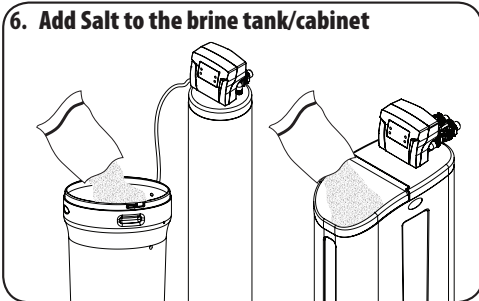

6. Put 40 kgs of crystal Specialty System salt in the brine tank. The unit will automatically fill the water to the correct level when it regenerates.

Key Points :

- ▶ Pay close attention to critical flow rates. If system flow rates exceed the specification for critical flow rates you may lose capacity and experience breakthrough for Iron, Mn, or Tannins. To be safe choose one size larger when sizing.
- ▶ Any oxidative pre-treatment such as air or chemicals is unnecessary and should be avoided.
- ▶ Cleaning chemicals are unnecessary and should be avoided as they may strip important coatings from the media reducing its effectiveness.
- ▶ High amounts of Ferric Iron (precipitated iron) or rust will not be filtered as the HIMTLC PLUS unit uses the ion exchange process. It may be necessary to add a filter ahead of the system to remove excess Ferric Iron or rust.
- ▶ Its very important to not run the system out of salt. In the event the system does run out of salt and

the unit is completely exhausted, an over night "soak" is recommended to clean the media. Soak Procedure is described above.

- ▶ Always be sure the salt tank has enough salt. The salt should always be above the wa-ter level in the tank. If you can see water its time to add salt. Keeping the salt above the water level insures a very high saturated brine solution and a good regeneration.
- ▶ On very bad problem water, the "soak" procedure may be performed regularly (monthly or as needed) to keep the media in good working condition.
- ▶ Units are designed to work with down flow valves only.
- ▶ A good back wash (15 minutes) is required as the friction of the media rubbing togeth-er releases the Iron and Manganese compounds from the surface of the media.

Automatic Raw Water Bypass During Regeneration

The regeneration cycle can last 80 minutes after which Softened water service will be restored. During regeneration, un-Softened water is automatically bypassed for use in the household. Hot water should be used as little as possible during this time to prevent un-Softened water from filling the water heater. This is why automatic regeneration is set for sometime during the night and manual regenerations should be performed when little or no water will be used in the household.

Manual Bypass

In the case of emergency you can isolate your Specialty System from the water supply using the bypass valve located at the back of the control. In normal operation the bypass is open with the on/off knobs in line with the inlet and outlet pipes.

To isolate the Softener, simply rotate the knobs clockwise (as indicated by the word BYPASS and arrow) until they lock. You can use your water related fixtures and appliances as the water supply is bypassing the Softener. However, the water you use will be untreated. To resume water service, open bypass valve by rotating the knobs counterclockwise. **Please make sure bypass knobs are completely open otherwise the unSoftened water could bypass through the valve.**

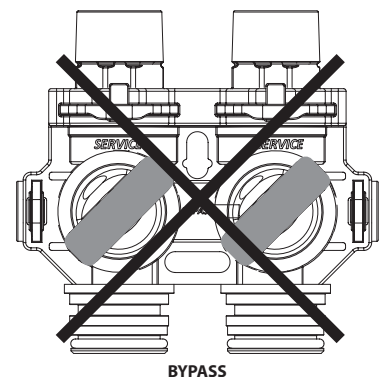

SYSTEM CHECK LIST

More than 90% of problems affecting the efficiency of a chemical iron free softener system can be identified in 9 minutes or less by following this diagnostic schedule. Start with Step 1, then follow each step in sequence to ensure proper diagnostic procedures.

1. Check for Proper Installation

- a. Is the pipe from the pressure tank to the softener unit attached to the inlet port of the control valve? Is the pipe from the softener unit to the water heater attached to the outlet port of the control valve?
- b. Is the drain line of adequate diameter? Drain line must be sized to prevent back pressure from reducing backwash flow rate below minimum for the model installed.

Typical examples of minimum drain line diameters are:

- i) 5/8" ID when drain is up to 15 ft from unit and backwash water discharge point is slightly higher than the control valve
- ii) 3/4" ID when drain is 25 ft away and/or drain is installed overhead
- c. Has the drain line been "kinked"? A kinked drain line must be replaced.
- d. Is the drain line installed in a way that it will freeze in cold weather?
- e. If the system incorporates a standard air-to-water pressure tank, does it have the required deep well air volume control (air release valve) and is it functioning? (Proper installation of this type of pressure tank should have inlet from pump higher than outlet to service.)

2. Check pH, Iron and Manganese Content of Treated Water

Is the treated water pH reading less than 6.7 (8.2 when manganese is present)? If yes, replenish the media with MpH adder and check the bed for "channelling".

3. Check Pumping Rate

Do not refer to a pumping rate curve for this data. Follow the instructions found on Page 7. Is the measured pumping rate less than the backwash rate of the softener? If yes, increase the pumping rate by first reducing the system operating pressure. If the pumping rate is still too low, replace the pump.

4. Determine Other Uses of Water in Addition to Normal Domestic Purposes

(e.g. geothermal heating or cooling, swimming pool fill, lawn irrigation, farm animal watering, etc.) Have any high demand water uses been added subsequent to the installation of the softener system or overlooked when originally sizing the system? (If a high demand situation exists, resize the system using continuous service flow rate data.)

DURING REGENERATION

Automatic Bypass

The regeneration cycle lasts approximately 60 minutes, after which treated water service will be restored. During regeneration, untreated water is automatically bypassed for use in the household. Hot water should be used as little as possible during this time to prevent hard water from filling the water heater.

IMPORTANT: This is why the automatic regeneration is set for sometime during the night and manual regenerations should be performed when little or no water will be used in the household.

New Sounds

You may notice new sounds as your Specialty System operates. The regeneration cycle lasts approximately 2-1/2 hours. During this time, you may hear water running intermittently to the drain.

PLUMBING SYSTEM CLEAN-UP

The following procedures are guidelines only but have proven successful in most instances. Under no circumstances should any procedure outlined below be followed if contrary to the appliance manufacturer's instructions. Should there be any questions concerning the advisability of performing a procedure, it is strongly recommended the manufacturer's authorized service outlet be consulted prior to performing the procedure.

The plumbing system and water using appliances that have been exposed, even for a short time, to iron-fouled water need to be cleaned of the precipitated iron that has collected in them or iron bleed (staining) will continue to be a problem.

Depending on the amount of iron in the water and the length of time the water system has been exposed to iron fouling, select from the following procedures those that apply to the type of system and appliances that need to be cleaned to assure iron-free water at the point of use.

Softener

1. Disconnect brine draw line from the brine cabinet and place the loose end into a five gallon plastic pail filled with a solution of warm water and 4 oz. of resin mineral cleaner.
2. Manually advance control timer to brine draw position (refer to instructions provided with your softener). Allow all the warm mineral cleaner solution to be drawn into mineral bed. Then immediately:
3. Close main water supply valve or turn power off to pump and proceed with Softener installation. During time required to install Softener system, iron- fouled softener resin will be chemically cleaned.

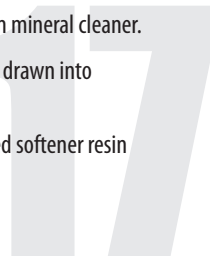

- After Softener installation is completed and final adjustments are made with the water turned on and brine draw tube reconnected, manually reposition timer on softener to backwash position. Allow timer to perform an automatic regeneration cycle. During backwash of softener, all iron cleaned from the resin will be washed down the drain. It is advisable, after chemically cleaning softener, to regenerate system twice to fully restore capacity lost due to iron fouling.

WATER BYPASS

Manual Bypass

In case of an emergency such as Softener maintenance, you can isolate your Specialty System from the water supply using the bypass valve located at the back of the control. In normal operation the bypass is open with the ON/OFF knobs in line with the INLET and OUTLET pipes. To isolate the Softener, simply rotate the knobs clockwise (as indicated by the word BYPASS and arrow) until they lock. You can use your water related fixtures and appliances as the watersupply is bypassing the softener. However, the water you use will be hard. To resume treated service, open the bypass valve by rotating the knobs counterclockwise. **Please make sure bypass knobs are completely open otherwise the unsoftened water could bypass through the valve.**

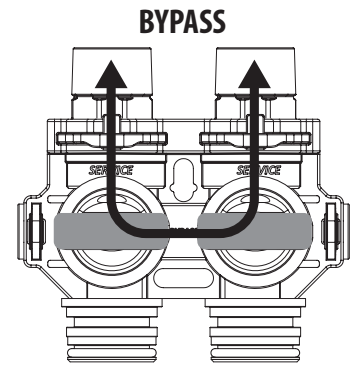
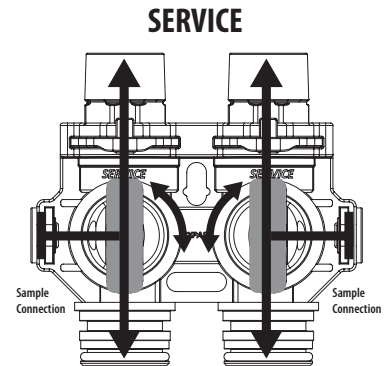
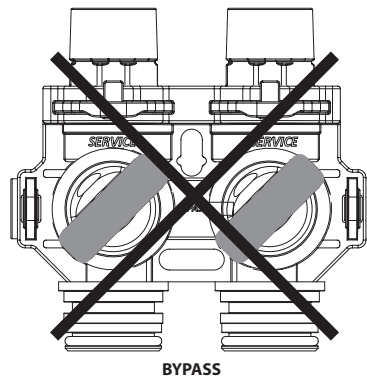

OPERATING CONDITIONS

Water Heater

If the water heater has been exposed to both iron and hardness for a long period of time, replacement of the heater tank maybe the only practical solution to prevent continued staining originating from this source. After completing the installation of the chemical free iron Softener system, clean the water heater by following these instructions:

- Shut off energy supply to water heater and close heater inlet water valve.
- Drain hot water tank completely. Open inlet water valve allowing heater tank to be refilled with iron-free water. Continue flushing until water runs clear to drain.
- If, after approximately 30 minutes flushing, water does NOT clear, terminate flushing operation. Refill hot water heater with water and pour approximately 1/2 gallon of household bleach into top of heater tank. Allow bleach solution to stand in tank for 20 to 30 minutes. Flush tank again until water is clear at drain. Turn energy supply on.

NOTE: If water does not clear in approximately 10 minutes, water heater should probably be replaced.

Dishwasher

Consult owners' handbook and follow manufacturer's instructions.

Toilet Flush Tanks

Prior to commencing installation of the Softener system, pour 4 to 6 ounces of resin mineral cleaner Pro-Rust Out or inhibited muriatic acid into flush tanks and bowls and let stand. When installation is completed, flush toilets several times with iron-free water. If iron deposits or stains remain, repeat procedure until clear.

NOTE: You should not be able to see water

Adding Salt

Use only clean salt labeled for water conditioner use, such as crystal, pellet, nugget, button or solar. The use of rock salt is discouraged because it contains insoluble silt and sand which build up in the brine tank and can cause problems with the system's operation. Add the salt directly to the tank, filling no higher than the top of the brine well.

Bridging

Humidity or the wrong type of salt may create a cavity between the water and the salt. This action, known as "bridging", prevents the brine solution from being made, leading to your water supply being hard.

If you suspect salt bridging, carefully pound on the outside of the plastic brine tank or pour some warm water over the salt to break up the bridge. This should always be followed up by allowing the unit to use up any remaining salt and then thoroughly cleaning out the brine tank. Allow four hours to produce a brine solution, then manually regenerate the softener.

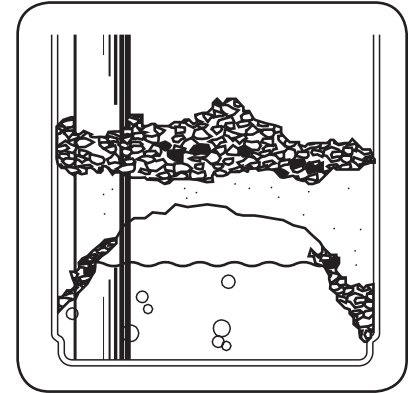

CAUTION: Liquid brine will irritate eyes, skin and open wounds - gently wash exposed area with fresh water. Keep children away from your water conditioner.

Care of Your Specialty System

To retain the attractive appearance of your new Specialty System, clean occasionally with a mild soap solution. Do not use abrasive cleaners, ammonia or solvents. Never subject your softener to freezing or to temperatures above 43°C (110°F).

Servicing Components

- The injector assembly should be cleaned or replaced every year depending on the inlet water quality and water usage.
- The seals and spacer cartridge should be inspected/cleaned or replaced every year depending on the inlet water quality and water usage.

Please refer to the servicing section of this manual for step by step procedure.

Not following the above will void all warranty on the control valve.

Resin Cleaners should never be used on your Specialty System

SERVICING 89 VALVE

Before Servicing

1. Turn off water supply to conditioner :
 - a. If the conditioner installation has a 3 valve bypass system first open the valve in the bypass line, then close the valves at the conditioner inlet & outlet.
 - b. If the conditioner has an integral bypass valve, put it in the bypass position.
 - c. If there is only a shut-off valve near the conditioner inlet, close it.
2. Relieve water pressure in the conditioner by stepping the control into the backwash position momentarily. Return the control to the In Service position.
3. Unplug Electrical Cord from outlet.
4. Disconnect drain line connection.



WARNING! ELECTRICAL SHOCK HAZARD! UNPLUG THE UNIT BEFORE REMOVING THE COVER OR ACCESSING ANY INTERNAL CONTROL PARTS.



CAUTION! Disassembly while under pressure can result in flooding. Always follow these steps prior to servicing the valve.

TIMER REPLACEMENT

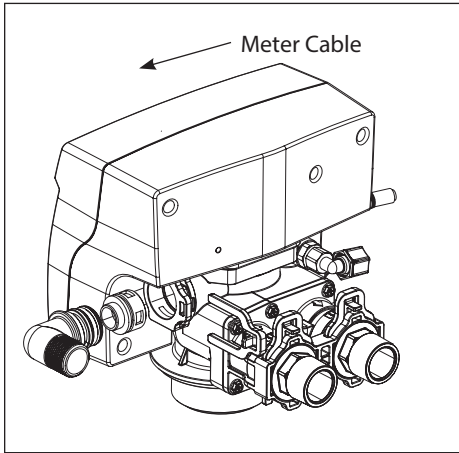

1. Disconnect the meter cable from the meter. (If flow meter is attached)

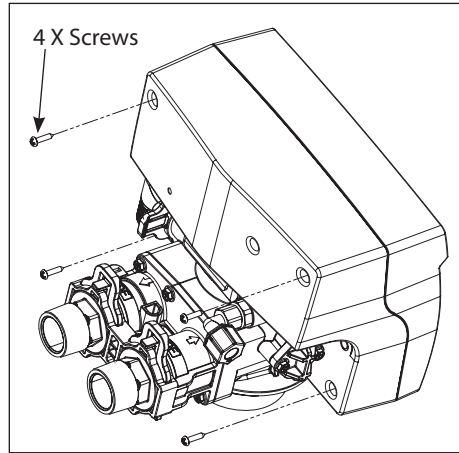

2. Remove four screws from the back of the valve cover

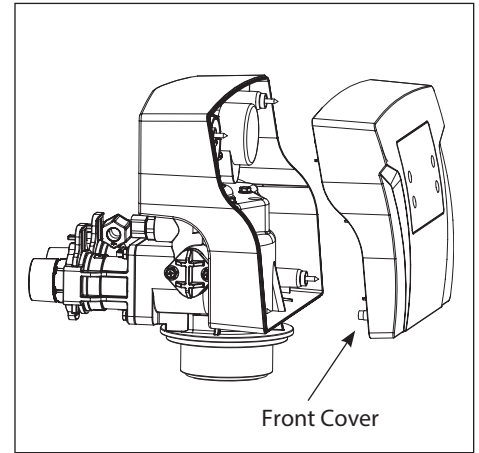

3. Remove the front cover of the valve.

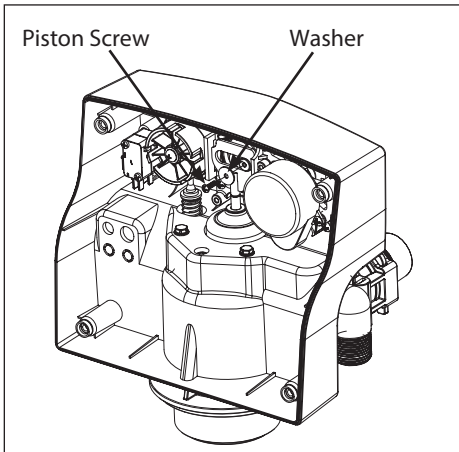

4. Remove the piston screw and washer from the piston rod.

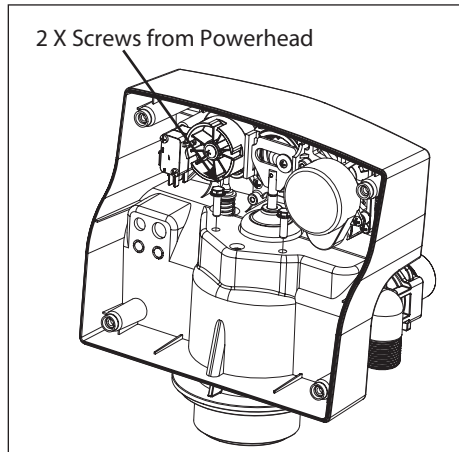

5. Remove the two screws from the powerhead as shown

6. Lift the powerhead from the valve body assembly

7. Replace the powerhead by reverse following the steps in this section

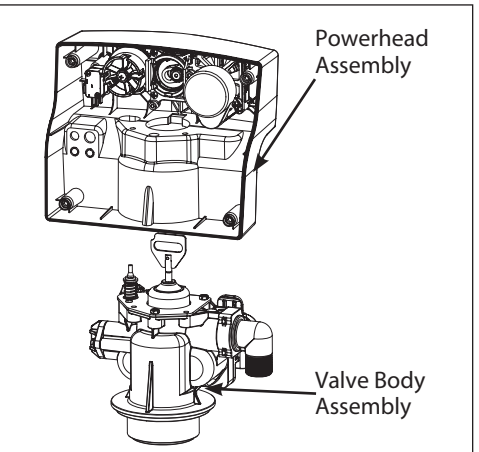

PISTON AND/OR BRINE VALVE ASSEMBLY REPLACEMENT

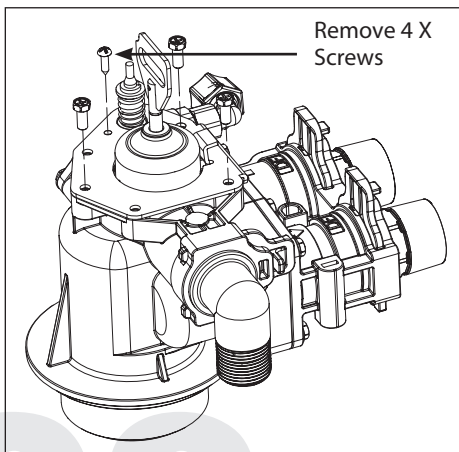

1. Follow steps 1 to 6 of timer /Powerhead replacement.
2. Remove four screws from the plate on the valve body.

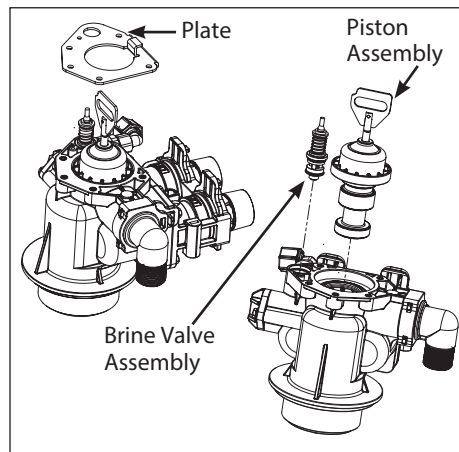

3. Remove the plate from the valve body and pull the Piston Assembly from the valve. The brine valve assembly can also be removed in this stage.

4. Remove the seal spacer assembly, grease it with silicone lubricant and put back in.

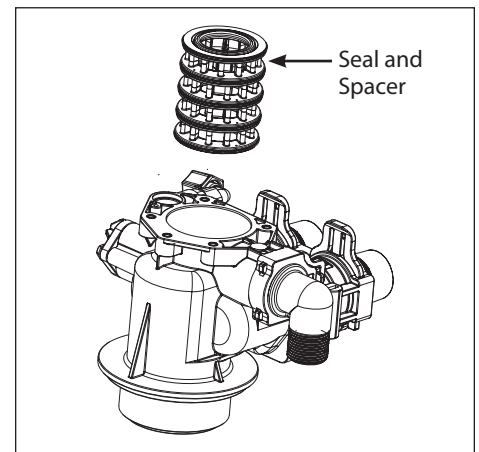

5. Replace piston assembly followed by timer assembly.
6. Replace the piston assembly and reverse following steps in this section

METER ASSEMBLY REPLACEMENT (For Models Manufactured after Valve Serial # Date of November 2015)

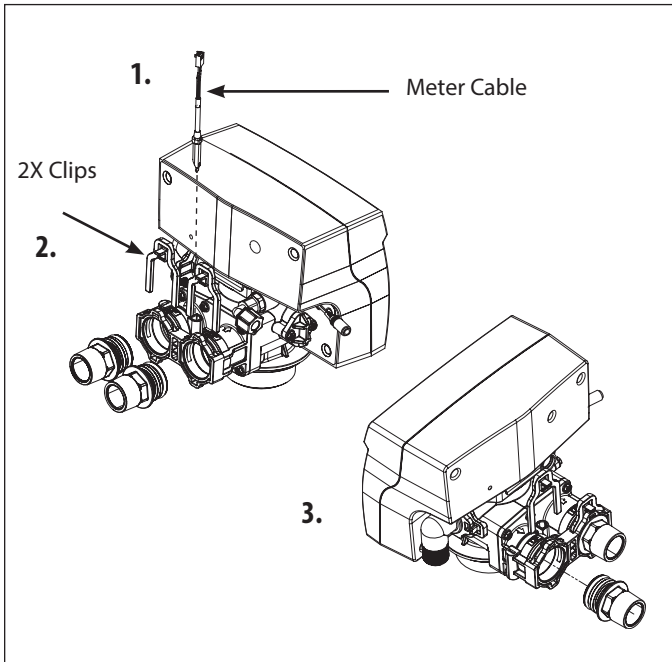

1. Disconnect the meter cable from the meter.
2. Disconnect the valve from bypass by removing clips
3. Remove the coupling adapter from the valve

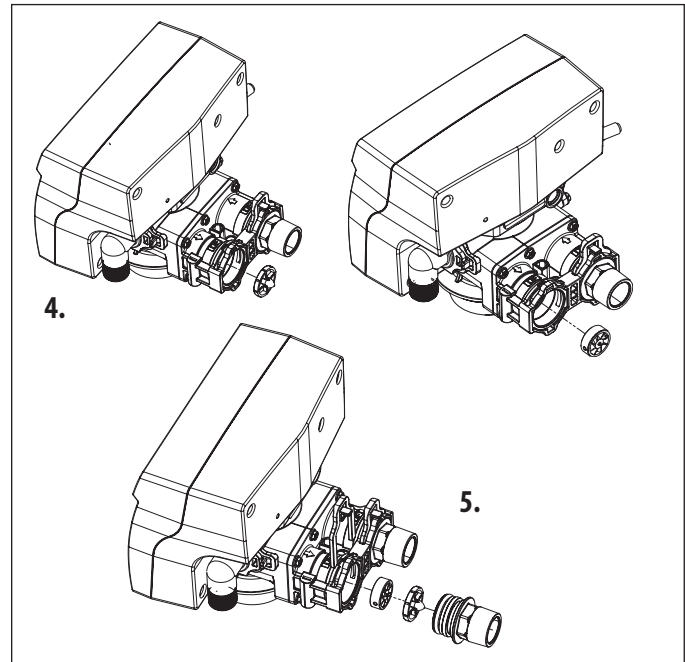

4. Remove the meter support and then the impeller out from the coupling and clean it
5. Replace meter with the help of special tool and re-assemble the removed components back in the section

CLEAN INJECTOR ASSEMBLY

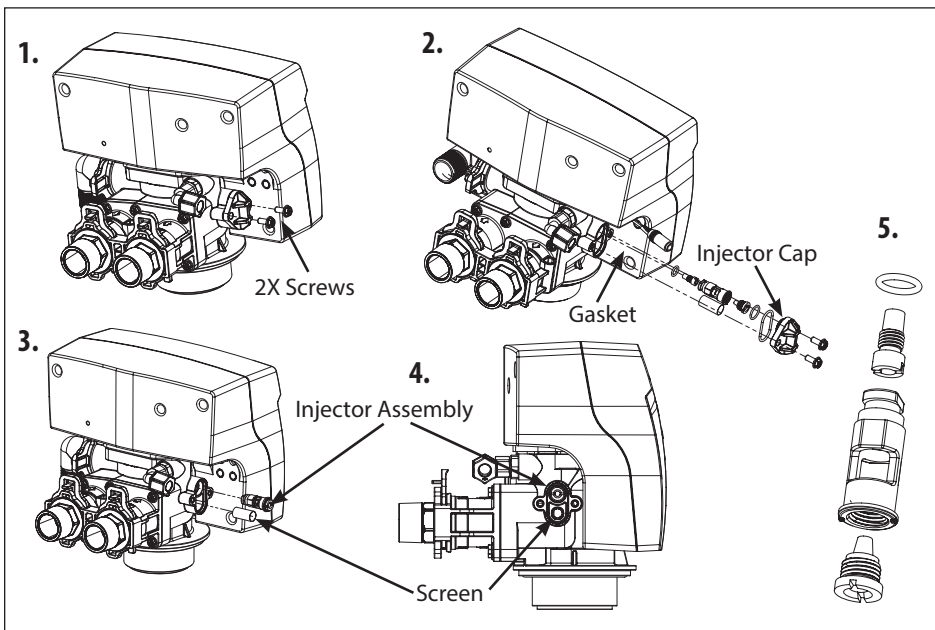

1. Remove the two screws from the injector cap
2. Pull the injector cap and gasket
3. Pull the injector assembly and Screen
4. Replace/Clean screen and injector assembly and put it back in the valve in appropriate location as shown
5. Put back the injector cap. Grease the injector assembly orings and injector cap gasket. Care should be taken to put all orings and gaskets in place and grease them so that they dont pinch

METER ASSEMBLY REPLACEMENT (For Models Manufactured before Valve Serial # Date of November 2015)

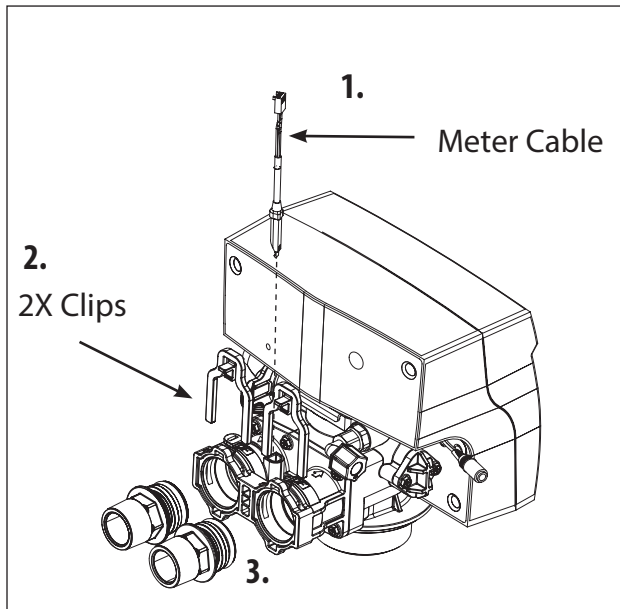

1. Disconnect the meter cable from the meter.
2. Disconnect the valve from bypass by removing clips
3. Remove the coupling adapter from the valve

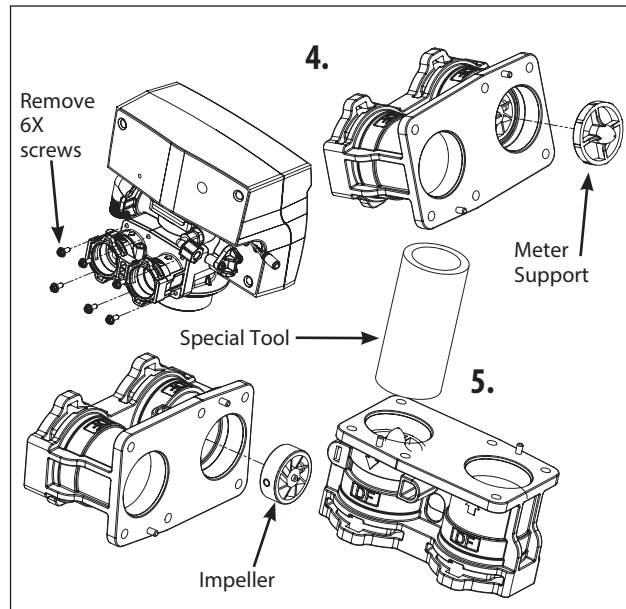

4. Remove six screws and pull out the meter support and impeller.
5. Replace meter with the help of special tool and re-assemble the removed components back in the section

REPLACE MOTOR

1. Remove Screws from the back of the valve and pull the cover
2. Remove all connections from the circuit board
3. Remove the two screws from the motor. Remove the motor and watch for the pin under the motor.
4. Replace the motor, connections and cover

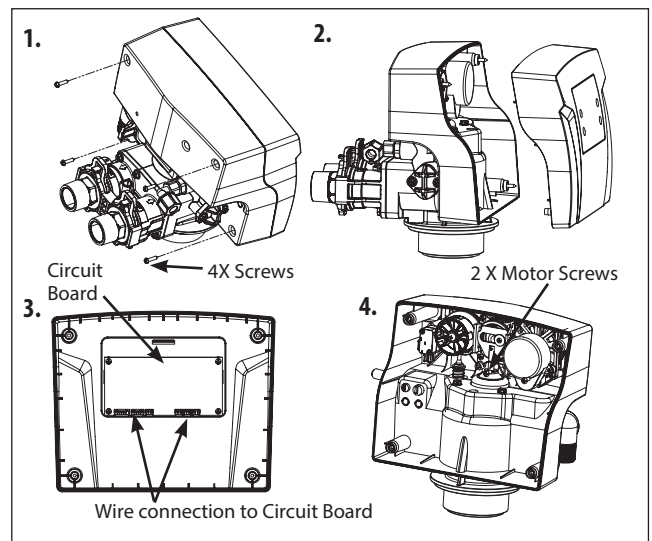

REPLACE MICROSWITCHES

1. Remove Screws from the back of the valve and pull the cover
2. Remove all connections from the circuit board
3. Remove the two screws from the microswitch
4. Replace the microswitch, connections and cover

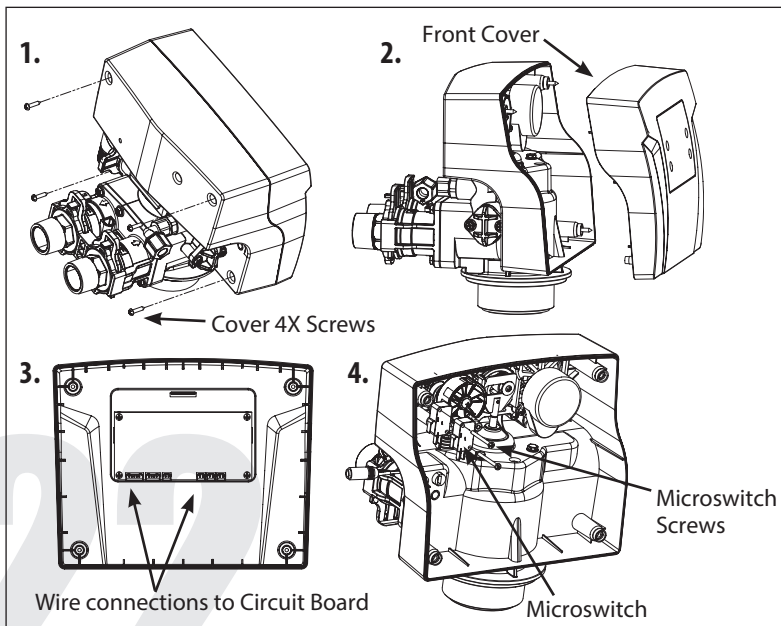

CIRCUIT BOARD REPLACEMENT

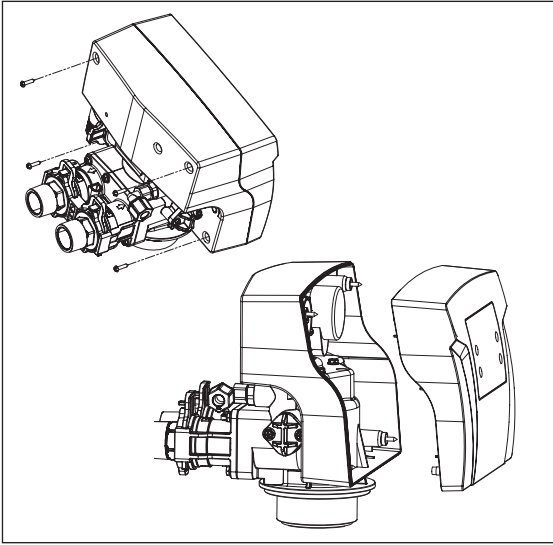

1. Remove the screws from the back of the valve and pull the front cover

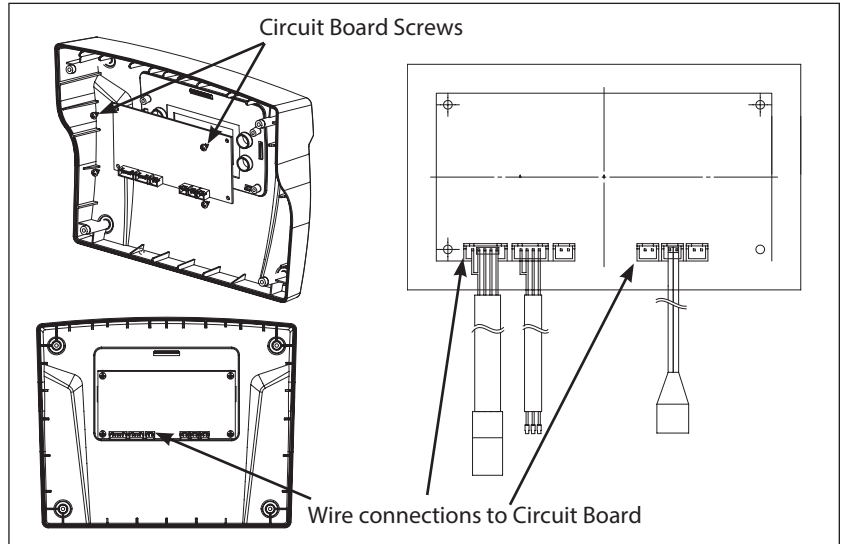

2. Remove all connections from the circuit board
3. Remove the four screws from the circuit board and pull it out

AFTER SERVICING

1. Reconnect drain line
2. Return bypass or inlet valve to normal in service position. Water Pressure will automatically build in the Softener

NOTE: Be sure to shut off any bypass line.

3. Check for leaks at all sealed areas. Check Drain seal with the control in the backwash position
4. Plug electrical cord into outlet
5. Set Time of Day and cycle the control valve manually to assure proper function. Make sure control valve is returned to the In Service position

PARTS BREAKDOWN

Control Valve

Upper Cone
(18280)

Bypass - 60010004

Distributor

Downflow Softener

Model	Mineral Tank Size	Tank # (Natural Color)	Tank # (Black Color)	Tank # (Blue Color)	Distrubutor#	Valve #
Softener Downflow (Single Tank)						
75	8 x 44	25010025	25010027	25010026	50010005	10010043
100	9 x 48	25010034	25010036	25010035	50010005	10010043
150	10 x 54	25010049	25010051	25010050	50010005	10010043
200	12 x 52	25010058	25010060	25010059	50010005	10010043
250	13 x 54	25010064	25010066	25010065	50010010	10010043
300	14 x 65	25030001 and 50040039	Not Available	Not Available	50010010	10010043
400	16 x 65	25030002 and 50040036	Not Available	Not Available	50010010	10010043

Upflow Softener

Model	Mineral Tank Size	Tank # (Natural Color)	Tank # (Black Color)	Tank # (Blue Color)	Distrubutor#	Valve #
Softener Downflow (Single Tank)						
75	8 x 44	25010025	25010027	25010026	50010005	10010044
100	9 x 48	25010034	25010036	25010035	50010005	10010044
150	10 x 54	25010049	25010051	25010050	50010005	10010044
200	12 x 52	25010058	25010060	25010059	50010005	10010044
250	13 x 54	25010064	25010066	25010065	50010010	10010044
300	14 x 65	25030001 and 50040039	Not Available	Not Available	50010010	10010044
400	16 x 65	25030002 and 50040036	Not Available	Not Available	50010010	10010044

PARTS BREAKDOWN

Controller assembly parts list

No.	Part #	Part Description	Qty
1	60010570	Controller front cover assembly	1
2	92388	89 PCB	1
3	60010571	PCB absorb shock foam	1
4	60010572	PCB fix screws	4
5	60010573	85HE mounting plate	1
6	60010574	Screws	8
7	92389	85 drive gear	1
8	60010099	Connect screw	1
9	92391	85HE main gear	1
10	60010575	Brine gear screw	1
11	60010576 60010577 - Used in AIO Models 60010578	Locating wheel assembly: three options Down flow wheel Up flow wheel Softener wheel	1
12	92392	85HE brine gear	1
13	60010579	Micro switch screws	2
14	60010580	Micro switch	2
15	60010076	Valve body connect screws	2
16	60010581	Controller screws	4
17	60010582	Controller back cover assembly	1
18	92393	Motor 12VAC 3W	1

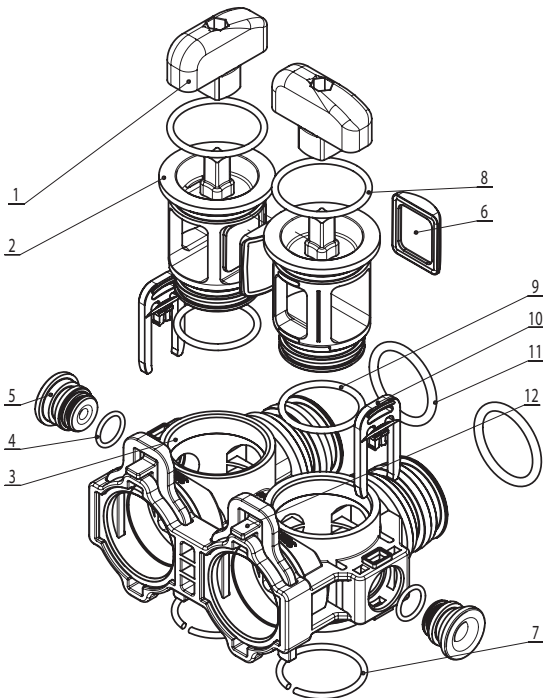
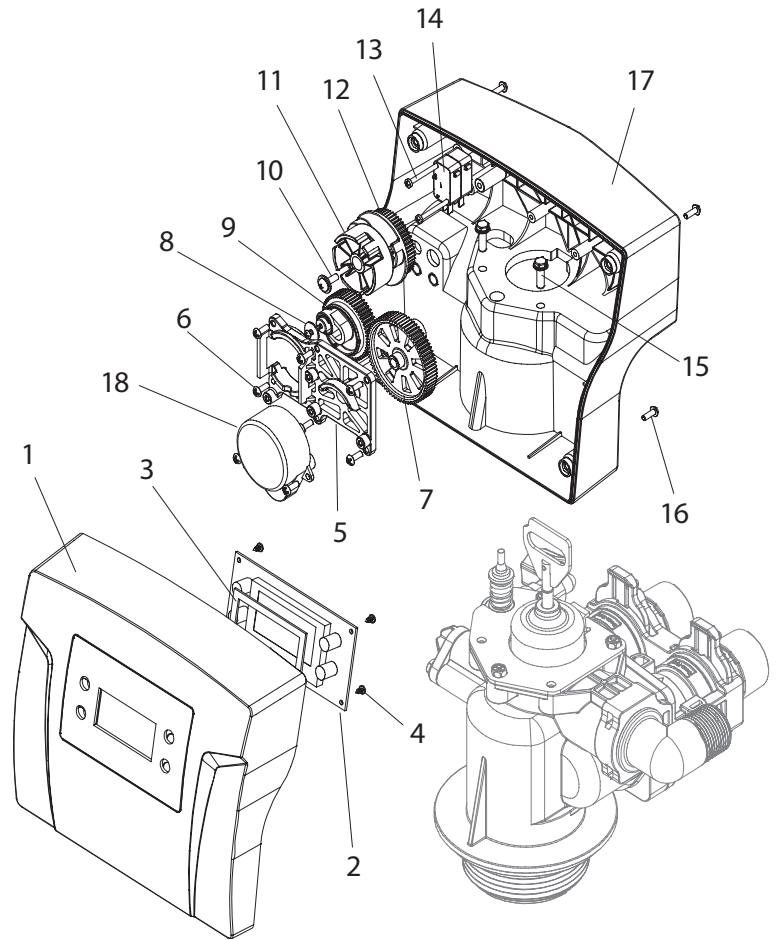

Bypass

No.	Part #	Part Description	Qty
1		89 Shaft Knob	2
2		BNT 89 Bypass Shaft	2
3		BNT 89 Bypass Body	1
4		Plug O-Ring 12.42×1.78	2
5	60010209	Bypass Plug	1
6		BNT 89 Bypass Knob Seal	8
7		Steel Retainer Ring	1
8		O-Ring 35.5×2.65	1
9		O-Ring 30×2.65	1
10	60010069	Plug Clip	1
11		O-Ring 30×3.55	1
12	92387	BNT89 Valve Clip	1

PARTS BREAKDOWN

Parts list of Standard connection assembly

No.	Part #	Part Description	Qty	No.	Part #	Part Description	Qty
1	60010258	Big O-ring of Adaptor coupling	2	6	92387	89 secure clip	2
2	60010585	Adaptor coupling of 89 control valve	2	7	60010589	89 valve connector	1
3	60010586	Small O-ring of adaptor coupling	2	8	60010590	Connector O-ring	2
4	60010587	Impeller holder	1	9	60010591 60010592	1"connector BSPT- Optional 1"connector NPT-Optional	2
5	60010238	Impeller assembly	1	10	60010593	Screws of valve connector	6

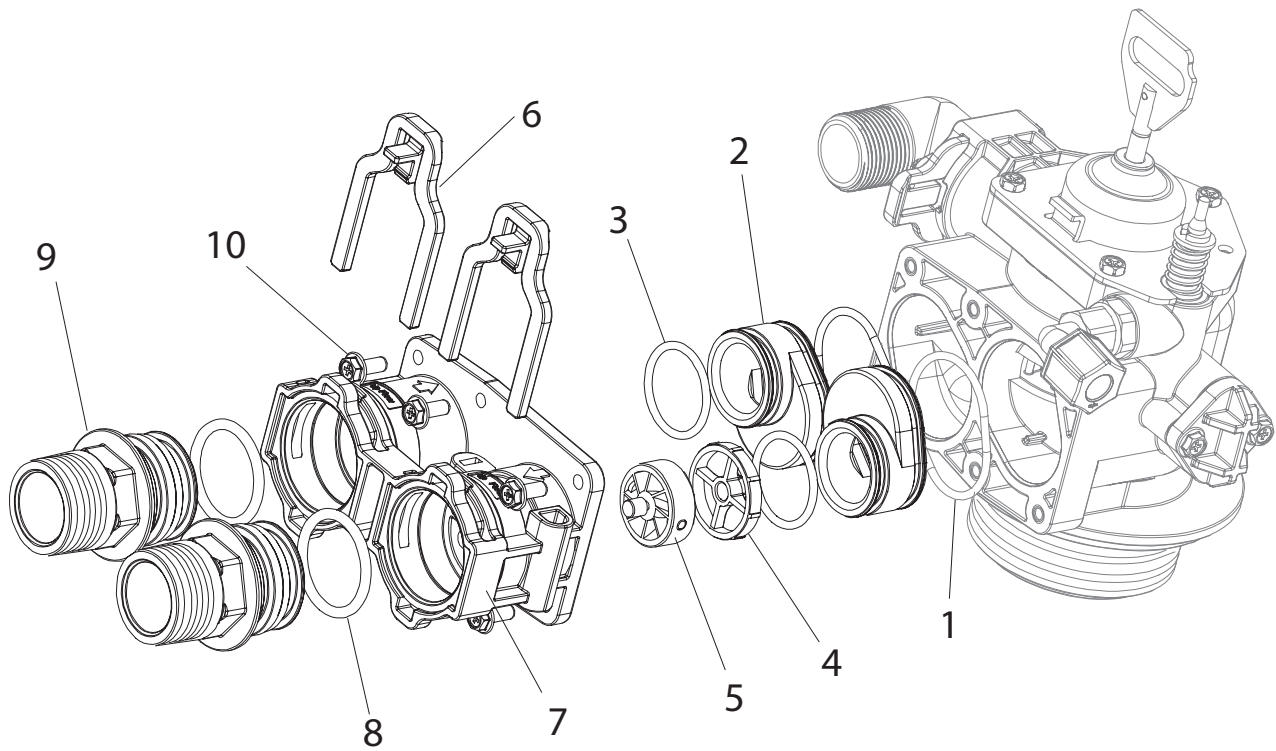

PARTS BREAKDOWN

Parts list of control valve body:

No.	Part #	Part Description	Qty
1		89 valve body	1
2	60010227	95 secure clip	1
3	See next section	DLFC assembly: optional 1S, 2S, 3S, 4S, 1#, 3#, 4#, 5#, 6#	1
4	60010211	Drain elbow O-ring	1
5	92397 60010233	Drain elbow: 1/2" 3/4"	1
6	92381 60010514	Brine valve injector stem assembly Brine line plug assembly	1
7	92382	Spacer and seal assembly	1
8	92393	Downflow Piston Assembly	1
9		Piston retainer	1
10		End plug	1
11		Piston pin	1
12		Piston rod	1
13		End plug retainer	1
14	60010075	End plug retainer screws	3
15	60010082	Brine line adaptor assembly: optional BLFC: 0.7gpm	1
16	See next section	Injector assembly: optional grey, purple, red, white, blue, yellow	1
17	60010091	Injector cover O-ring	1
18	60010595	Injector cover	1
19	60010596	Injector cover screws	2
20	60010077	Tank mouth O-ring	1
21	60010597	Adapter O-ring	1
22	60010598	Center pipe adapter	1
23	60010080	Center pipe O-ring	1
24	60010599	Valve bottom connector	1
25	60010099	Bottom connector screws	2
26	60010088	Brass nuts	1
27	60010600	Brine line elbow assembly	1

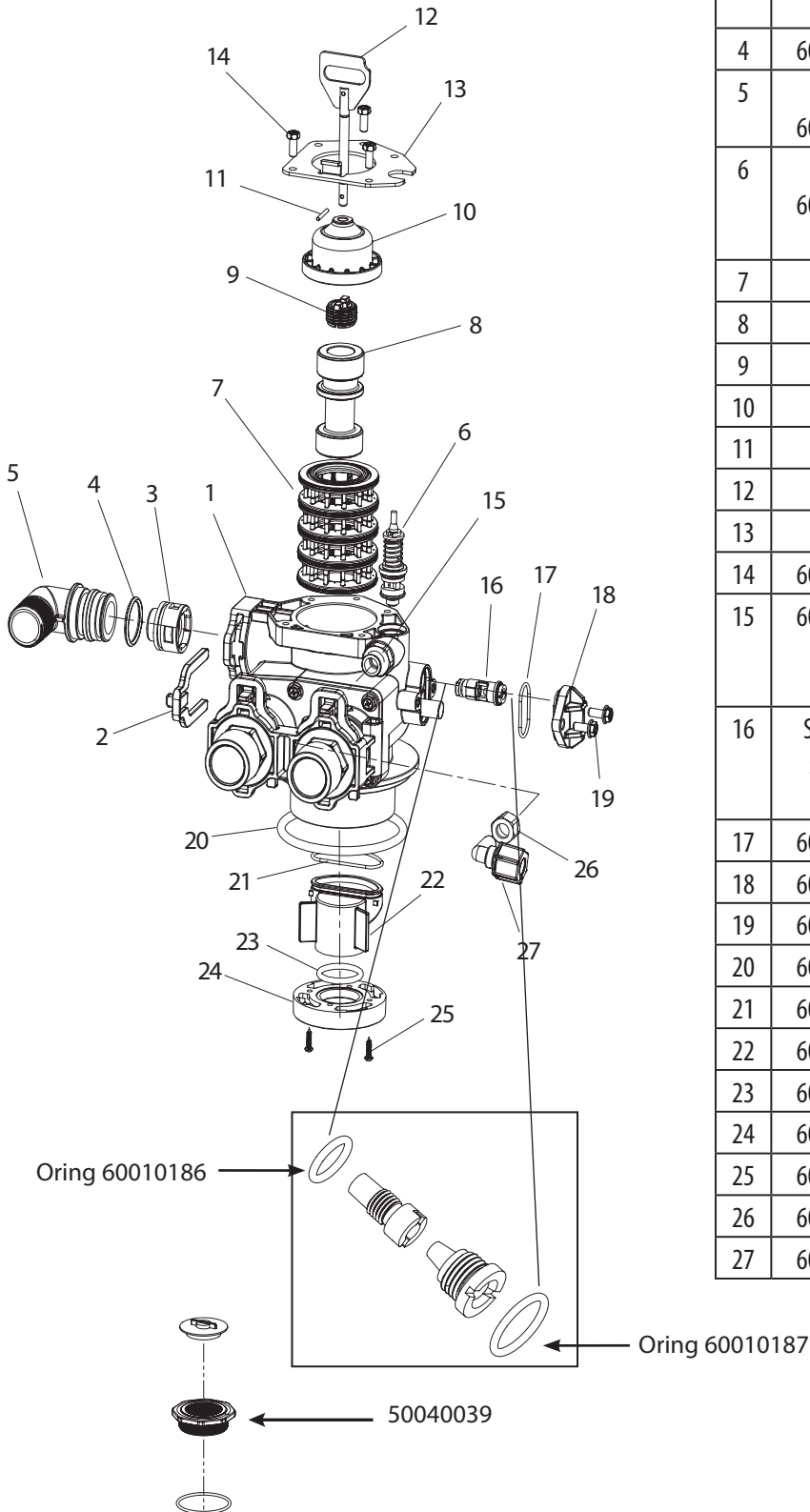

PARTS BREAKDOWN

DLFC PART # for 89 VALVE

No.	Part #	Part Description	Qty
1	60095720	BNT95DLFC-0(4.0 GPM)	1
2	60010143	BNT95DLFC-1(7.0GPM)	1
3	60010144	BNT95DLFC-2(11.0GPM)	1
4	60010145	BNT95DLFC-3(14.0GPM)	1
5	60010146	BNT95DLFC-4(17.0GPM)	1
6	60010147	BNT95DLFC-5(21.0GPM)	1
7	60095692	BNT95DLFC-6(24.0GPM)	1
8	60095721	BNT95DLFC-1S(2.4GPM)	1
9	60095722	BNT95DLFC-2S(3.5GPM)	1
10	60095723	BNT95DLFC-3S(4.5GPM)	1
11	60010140	BNT95DLFC-4S(5.0GPM)	1
12	60095724	BNT95DLFC-5S(6.0GPM)	1
13	60095725	BNT95DLFC-6S(6.0GPM)	1
14	60010142	BNT95DLFC-7S(7.0GPM)	1

BLFC PART # for 89 VALVE

No.	Part #	Part Description	Qty
1	60010128	BNT95BLFC (0.2 GPM)	1
2	12053	BNT95BLFC-1(2.0 GPM)	1
3	60010162	BNT95 BLFC-7(1.35 GPM)	1

INJECTOR PART # for 89 VALVE

No.	Part #	Part Description	Qty
1	60010601	INJECTOR THROAT(BLACK 0000#)	1
2	60010602	INJECTOR NOZZLE(BLACK 0000#)	1
3	60010603	INJECTOR THROAT(GREY 000#)	1
4	60010604	INJECTOR NOZZLE(GREY 000#)	1
5	60010605	INJECTOR THROAT(PURPLE 00#)	1
6	60010606	INJECTOR NOZZLE (PURPLE 00#)	1
7	60010607	INJECTOR THROAT(RED 0#)	1
8	60010608	INJECTOR NOZZLE(RED 0#)	1
9	60010609	INJECTOR THROAT (WHITE 1#)	1
10	60010610	INJECTOR NOZZLE (WHITE 1#)	1
11	60010611	INJECTOR THROAT(BLUE 2#)	1
12	60010612	INJECTOR NOZZLE(BLUE 2#)	1
13	60010613	INJECTOR THROAT(YELLOW 3#)	1
14	60010614	INJECTOR NOZZLE(YELLOW 3#)	1

**No 10 and 11 Injector
Parts Apply to A10
Models**

TROUBLE SHOOTING GUIDE

Problem	Possible Solutions
<p>1. CONDITIONER DELIVERS HARD WATER</p> <p>A. Bypass valve is open B. No salt in brine tank C. Injector or screen plugged D. Insufficient water flowing into brine tank E. Hot water tank hardness F. Leak at distributor tube G. Internal valve leak H. Flow meter jammed I. Flow meter cable disconnected or not plugged into meter cap J. Improper programming</p>	<p>A. Close bypass valve B. Add salt to brine tank and maintain salt level above water level C. Replace injectors and screen D. Check brine tank fill time and clean brine line flow tank control if plugged E. Make sure distributor tube is not cracked. Check O ring and tube pilot F. Make sure distributor tube is not cracked. Check O ring and tube pilot G. Replace seals and spacers and/or piston H. Remove obstruction from flow meter I. Check meter cable connection to timer and meter cap J. Reprogram the control to the proper regeneration type, inlet water hardness, capacity or flow meter size.</p>
<p>2. CONDITIONER FAILS TO REGENERATE</p> <p>A. Electrical service to unit has been interrupted B. Timer is not operating properly C. Defective valve drive motor D. Improper programming</p>	<p>A. Assure permanent electrical service (check fuse, plug, chain or switch) B. Replace timer C. Replace drive motor D. Check programming and reset as needed</p>
<p>3. UNIT USES TOO MUCH SALT</p> <p>A. Improper salt setting B. Excessive water in brine tank C. Improper programming</p>	<p>A. Check salt usage and salt setting B. See #7 C. Check programming and reset as needed</p>
<p>4. LOSS OF WATER PRESSURE</p> <p>A. Iron build-up in line to water conditioner B. Iron build-up in water conditioner C. Inlet of control plugged due to foreign material broken loose from pipes by recent work done on plumbing system.</p>	<p>A. Clean line to water conditioner B. Clean control and add resin cleaner to resin bed. Increase frequency of regeneration C. Remove piston and clean control</p>
<p>5. LOSS OF RESIN THROUGH DRAIN LINE</p> <p>A. Air in water system B. Drain line flow control is too large</p>	<p>A. Assure that well system has proper air eliminator control. Check for dry well condition. B. Ensure drain line flow control is sized</p>
<p>6. IRON IN CONDITIONED WATER</p> <p>A. Fouled resin bed B. Iron content exceeds recommended parameters</p>	<p>A. Check backwash, brine draw and brine tank fill. Increase frequency of regeneration. Increase backwash time. B. Add iron removal filter system</p>
<p>7. EXCESSIVE WATER IN BRINE TANK</p> <p>A. Plugged drain line flow control B. Brine valve failure C. Improper programming</p>	<p>A. Clean flow control B. Replace brine valve C. Check programming and reset as needed</p>
<p>8. SALT WATER IN SERVICE LINE</p> <p>A. Plugged injector system B. Timer not operating properly C. Foreign material in brine valve D. Foreign material in brine line flow control E. Low water pressure F. Improper programming</p>	<p>A. Clean injector and replace screen B. Replace timer C. Clean or replace brine valve D. Clean brine line flow control E. Raise water pressure F. Check programming and reset as needed</p>
<p>9. CONDITIONER FAILS TO DRAW BRINE</p> <p>A. Drain line flow control is plugged B. Injector is plugged C. Injector screen is plugged D. Line pressure is too low E. Internal control leak F. Improper programming G. Timer not operating properly</p>	<p>A. Clean drain line flow control B. Clean or replace injectors C. Replace screen D. Increase line pressure (line pressure must be at least 20 psi at all times) E. Change seals and spacers and/or piston assembly F. Check programming and reset as needed G. Replace timer</p>
<p>10. CONTROL CYCLES CONTINUOUSLY</p> <p>A. Timer not operating properly B. Faulty microswitches and/or harness C. Faulty cycle cam operation</p>	<p>A. Replace timer B. Replace faulty microswitch or harness C. Replace cycle cam or reinstall</p>

TROUBLE SHOOTING GUIDE

Problem	Possible Solutions
11. DRAIN FLOWS CONTINUOUSLY A. Foreign material in control B. Internal control leak C. Control valve jammed in brine or backwash position D. Timer motor stopped or jammed teeth E. Timer not operating properly	A. Remove piston assembly and inspect bore. Remove foreign material and check control in various regeneration positions B. Replace seals and/or piston assembly C. Replace piston and seals and spacers D. Replace timer motor and check all gears for missing teeth E. Replace timer
12. (Error Code) (Error E1) - Electrical Trouble Shooting: Issue1: When the controller is plugged, the buzzer beeps and the screen displays "System Error E1" Cause: The wire of micro switch is not plugged or loose.	Check the micro switch and connect the wire well.
13. (Error Code) (Error E2) - Electrical Trouble Shooting: Issue2: The buzzer beeps and the screen displays "System Error E2" Cause: The motor can not find its right position, micro switch or motor malfunction, automatic circuit protection action.	Check the current of micro switch and motor.

MASTER PROGRAMMING GUIDE

Below is how the settings are set at factory:

Downflow Valve Programming (Models 89DF)

PRESS '+' AND '-' FOR 8 SECONDS							PRESS MENU KEY AND SCROLL TO 'MAIN MENU'. THEN PRESS 'SET' TILL IT BEEPS. SCROLL TO ADVANCED MENU										PRESS MENU KEY AND SCROLL TO 'MAIN MENU'. THEN PRESS 'SET' TILL IT BEEPS				VALVE SETTINGS				
MODELS	LANGUAGE	REGION	VALVE	METER RATIO	SALT VS EFFICIENCY	AUTO CALCULATION	RESIN VOLUME	REFILL RATE	REGEN. MODE	BACKWASH OVERRIDE	EMERGENCY REGEN.	REGEN CYCLES	BACKWASH DURATION	BRINE DRAW DURATION	RINSE DURATION	REFILL DURATION	REGEN TIME SETTING	REGEN DAY SETTING	SYSTEM CAPACITY	SALT MODE SETTING	Injector	Injector Color	BLFC Washer	DLFC Washer	DLFC Washer Code
75	ENGLISH	US GALLONS	DOWNFLOW	1.393	DONT TOUCH	ON	0.75CF	0.7 GPM	METER DELAY	OFF	OFF		10	60	10	N/A	2:00AM	N/A	N/A	STANDARD	#1	White	0.7 GPM	1.4	#7
100	ENGLISH	US GALLONS	DOWNFLOW	1.393	DONT TOUCH	ON	1.0CF	0.7 GPM	METER DELAY	OFF	OFF		10	60	10	N/A	2:00AM	N/A	N/A	STANDARD	#1	White	0.7 GPM	2.0	#2
150	ENGLISH	US GALLONS	DOWNFLOW	1.393	DONT TOUCH	ON	1.5CF	0.7 GPM	METER DELAY	OFF	OFF		10	60	10	N/A	2:00AM	N/A	N/A	STANDARD	#1	White	0.7 GPM	2.4	15
200	ENGLISH	US GALLONS	DOWNFLOW	1.393	DONT TOUCH	ON	2.0CF	0.7 GPM	METER DELAY	OFF	OFF		10	60	10	N/A	2:00AM	N/A	N/A	STANDARD	#2	Blue	0.7 GPM	3.5	25
250	ENGLISH	US GALLONS	DOWNFLOW	1.393	DONT TOUCH	ON	2.5CF	0.7 GPM	METER DELAY	OFF	OFF		10	60	10	N/A	2:00AM	N/A	N/A	STANDARD	#2	Blue	0.7 GPM	4.0	35
300	ENGLISH	US GALLONS	DOWNFLOW	1.393	DONT TOUCH	ON	3CF	0.7 GPM	METER DELAY	OFF	OFF		10	60	10	N/A	2:00AM	N/A	N/A	STANDARD	#3	Yellow	0.7 GPM	5.0	45

MASTER PROGRAMMING 89 DOWNFLOW VALVE (89 DF MODELS)

The controller will show the following on the screen - Time, Date and number of Days Remaining for Regeneration:

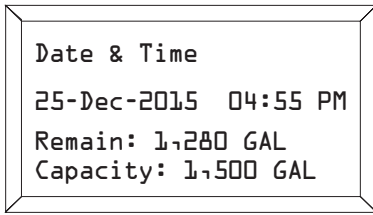





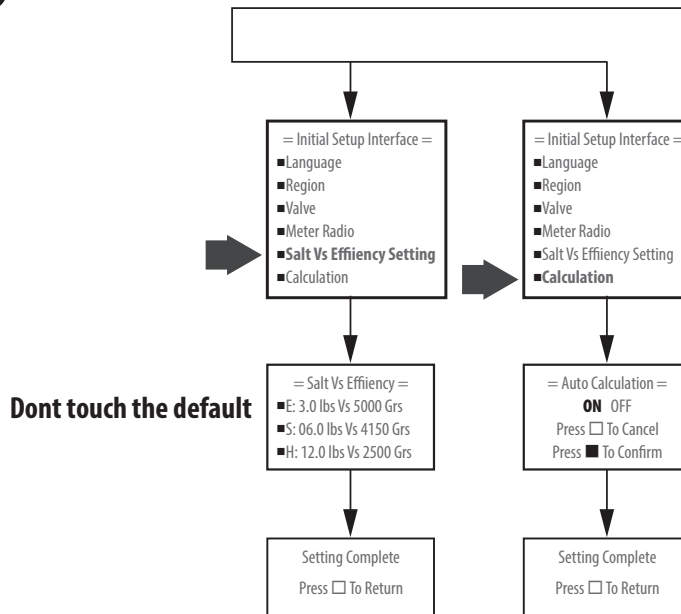
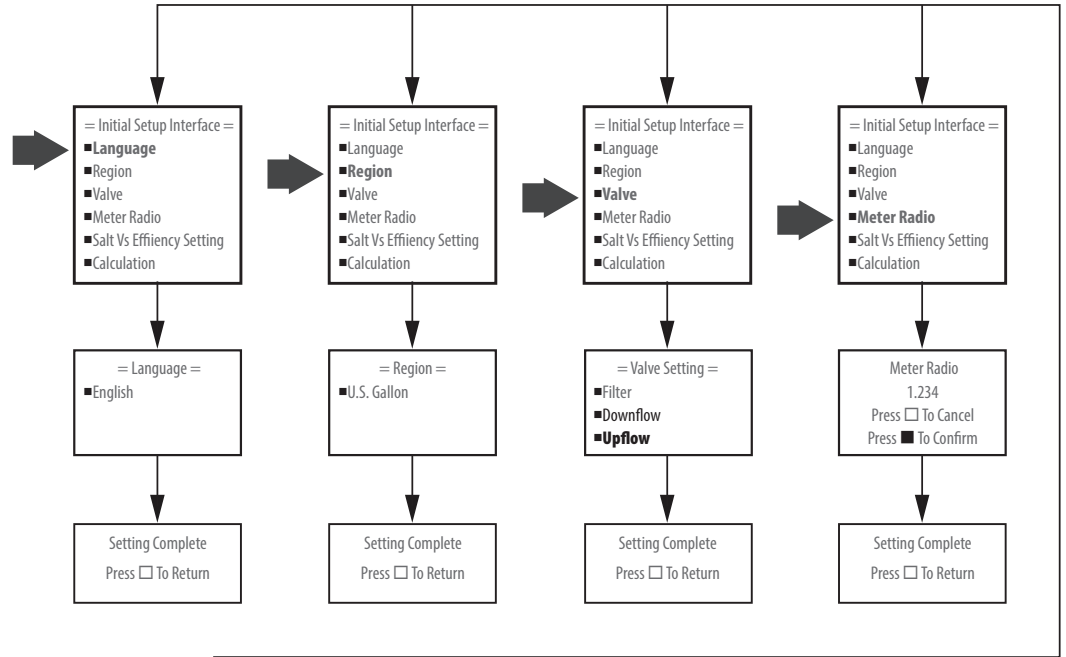



How to set Master Programming (Authorized Dealer Only)

Press "+" and "-" for 8 seconds.
Press "SET" to select and "MENU" to go back



MASTER PROGRAMMING GUIDE 89 DOWNFLOW

ADVANCED MENU PRESS "MENU" KEY AND SCROLL TO "MAIN MENU". THEN PRESS "SET" TILL IT BEEPS. SCROLL TO ADVANCED MENU

Press "Menu" key . Press - to advance to Advanced Menu Press and hold "SET"  5 seconds or until you hear a beep. Press "+"  or "-"  to choose menu option. Press "SET"  to enter. Press "+"  or "-"  to change option. Press "SET"  to accept.

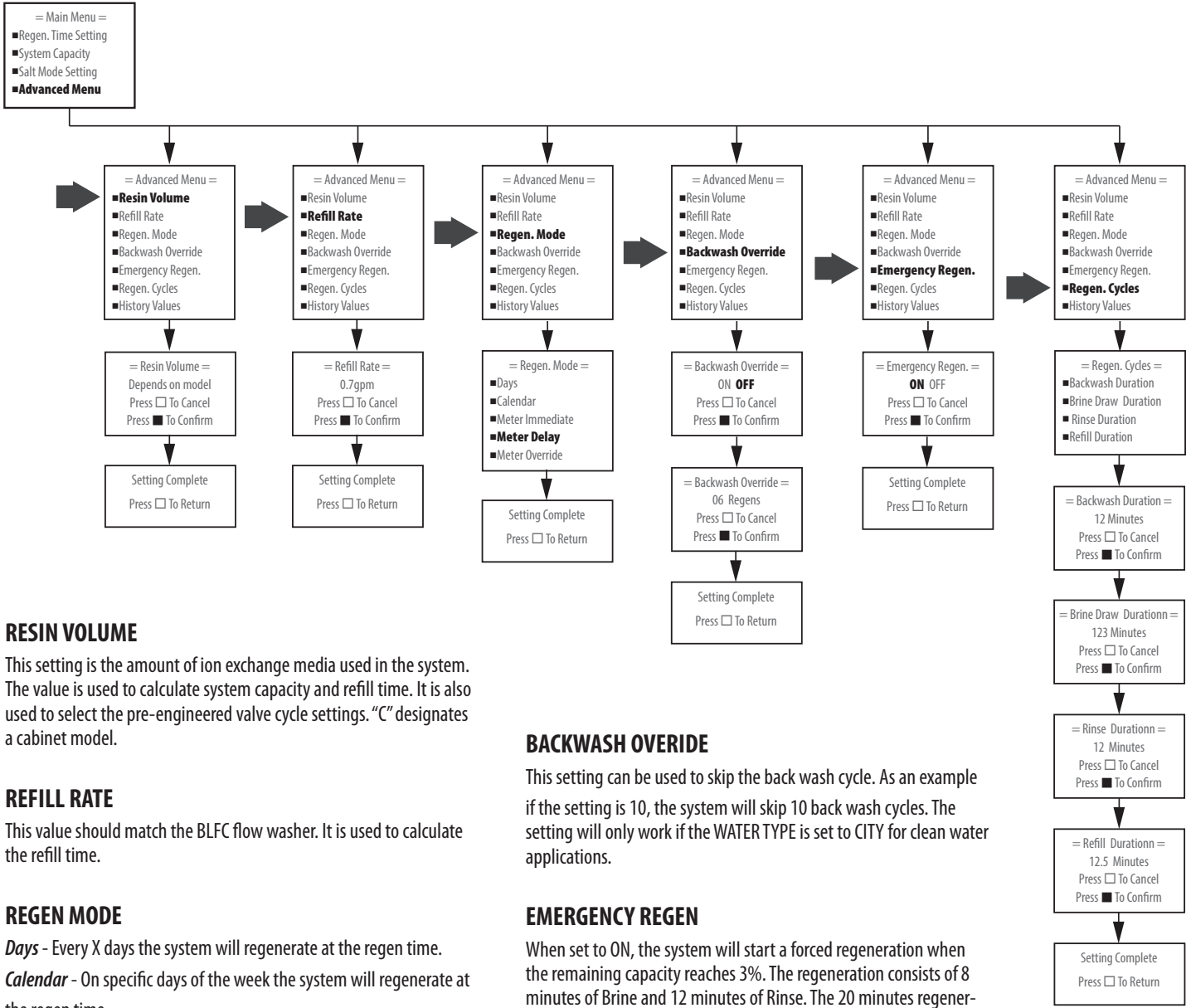

RESIN VOLUME

This setting is the amount of ion exchange media used in the system. The value is used to calculate system capacity and refill time. It is also used to select the pre-engineered valve cycle settings. "C" designates a cabinet model.

REFILL RATE

This value should match the BLFC flow washer. It is used to calculate the refill time.

REGEN MODE

Days - Every X days the system will regenerate at the regen time.

Calendar - On specific days of the week the system will regenerate at the regen time.

Meter Immediate - When the volume remaining reaches zero gallons the system will immediately regenerate.

Meter Delayed - When the volume remaining goes below the calculated reserve for that day the system will regenerate at the regen time.

Meter Override - When the volume remaining goes below the calculated reserve for that day the system will regenerate at the regen time or when X days has passed. Which ever occurs first.

BACKWASH OVERRIDE

This setting can be used to skip the back wash cycle. As an example if the setting is 10, the system will skip 10 wash cycles. The setting will only work if the WATER TYPE is set to CITY for clean water applications.

EMERGENCY REGEN

When set to ON, the system will start a forced regeneration when the remaining capacity reaches 3%. The regeneration consists of 8 minutes of Brine and 12 minutes of Rinse. The 20 minutes regeneration will restore up to 33% of the system capacity. At the next regeneration time (2:00 AM), the system will automatically perform a standard regeneration to restore capacity to 100%.

RESIN VOLUME

This setting is the amount of ion exchange media used in the system. The value is used to calculate system capacity and refill time. It is also used to select the pre-engineered valve cycle settings. "C" designates a cabinet model.

REFILL RATE

This value should match the BLFC flow washer. It is used to calculate the refill time.

REGEN MODE

Days - Every X days the system will regenerate at the regen time.

Calendar - On specific days of the week the system will regenerate at the regen time.

Meter Immediate - When the volume remaining reaches zero gallons the system will immediately regenerate.

Meter Delayed - When the volume remaining goes below the calculated reserve for that day the system will regenerate at the regen time.

Meter Override - When the volume remaining goes below the calculated reserve for that day the system will regenerate at the regen time or when X days has passed. Which ever occurs first.

BACKWASH OVERRIDE

This setting can be used to skip the back wash cycle. As an example if the setting is 10, the system will skip 10 back wash cycles. The setting will only work if the WATER TYPE is set to CITY for clean water applications.









EMERGENCY REGEN

When set to ON, the system will start a forced regeneration when the remaining capacity reaches 3%. The regeneration consists of 8 minutes of Brine and 12 minutes of Rinse. The 20 minutes regeneration will restore up to 33% of the system capacity. At the next regeneration time (2:00 AM), the system will automatically perform a standard regeneration to restore capacity to 100%.

UF SOFTENER (UP FLOW)

This mode is for the operation of an up flow regenerating softener. The regeneration sequence is 1. BRINE MAKE (REFILL), 2. BRINE, 3. BACKWASH, 4 RINSE, 5. REFILL.

MAIN MENU 89 DOWNFLOW

Press "Menu" key . Press - to advance to Advanced Menu Press and hold "SET"  5 seconds or until you hear a beep. Press "+"  or "-"  to choose menu option. Press "SET"  to enter. Press "+"  or "-"  to change option. Press "SET"  to accept.

REGEN TIME

This setting determines the time of day to perform a scheduled regeneration.

SYSTEM CAPACITY

In Auto Calculation mode the system capacity is calculated. It can be manually adjusted as well.

SALT MODE SETTING

There are 3 settings to choose. Economy, Standard, and High Capacity.

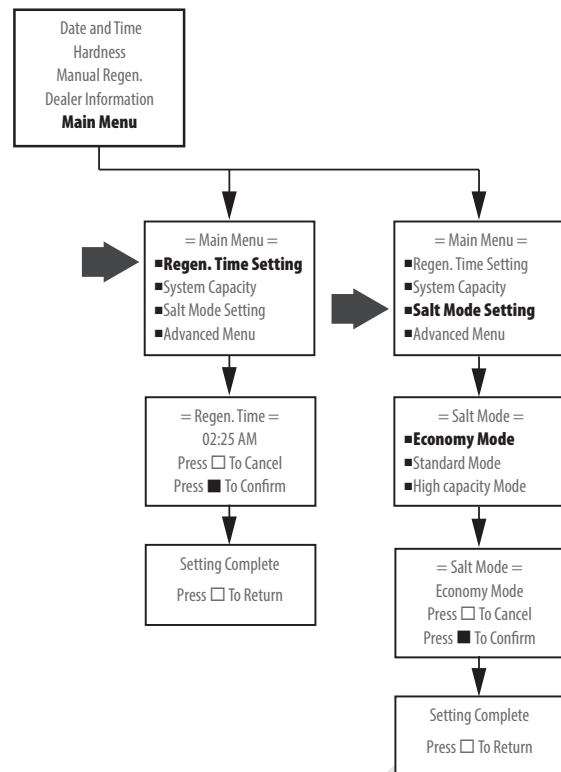

DIAGNOSTIC SCREEN

PRESS "MENU" KEY  AND SCROLL TO "MAIN MENU". THEN PRESS "SET"  TILL IT BEEPS. SCROLL TO ADVANCED MENU

Press "Menu" key . Press - to advance to Main Menu

Press "SET"  or until you hear a beep.

Press - to advance to Advanced Menu

Press and hold "SET"  5 seconds or until you hear a beep.

Press - to advance to History Values

Press "SET"  or until you hear a beep.

Press "+"  or "-"  to choose menu option. Press "SET"  to enter.

Press "+"  or "-"  to change option. Press "SET"  to accept.

PARAMETER	DESCRIPTION
LAST REGEN ON	Date of last system regeneration.
USED SINCE REGEN	Volume used since last regeneration.
CURRENT FLOW RATE	The current system flow rate.
PEAK FLOW RATE	The peak or highest flow rate since last regeneration.
SOFTWARE VERSION	The software version programmed on the PCB.
RESERVE	The calculated reserve for each day based on the highest days usage over the past 4 weeks.
28 DAYS HISTORY	The volume used for each of the last 28 days.
USAGE HISTORY	The usage since system start up and from the last reset.
TOTAL USED	The total volume used.
TOTAL REGENS	The total quantity of regenerations.
TOTAL DAYS	The total days in operation.

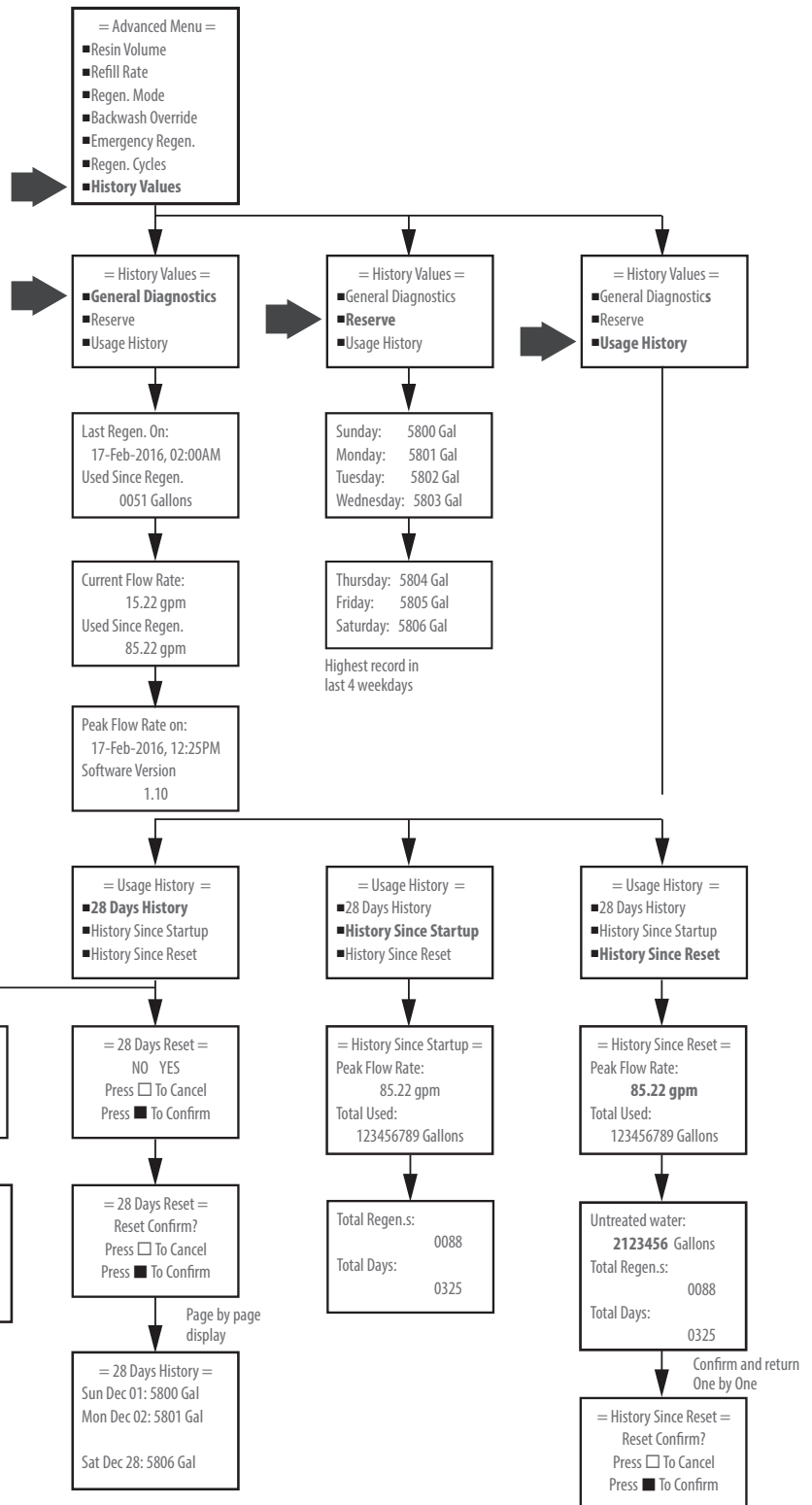

HOW TO SET DATE AND TIME, MANUAL REGENERATION AND DEALER INFORMATION

PRESS "MENU" KEY  AND SCROLL TO "MAIN MENU". THEN PRESS "SET"  TILL IT BEEPS.

Press "Menu" key 

Press "+"  or "-"  to change menu option. Press "SET"  to enter.

Press "+"  or "-"  to change value. Press "SET"  to accept.

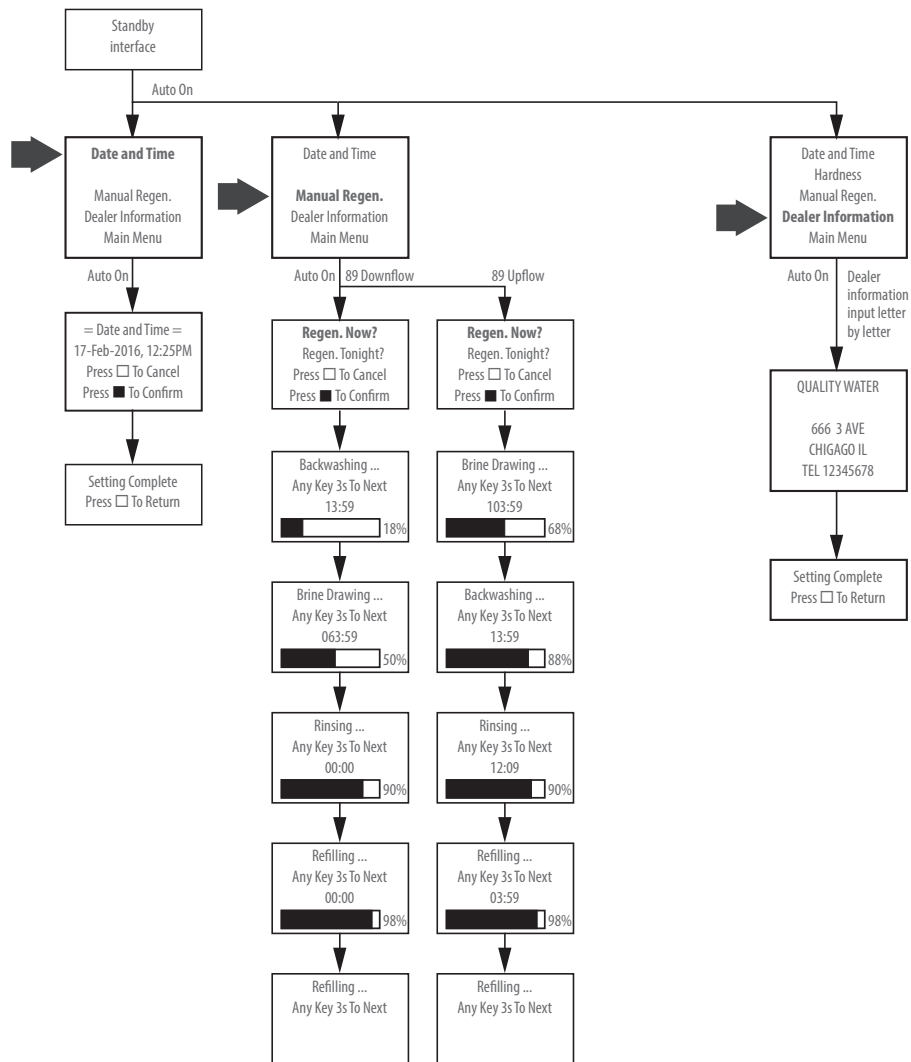

DATE AND TIME

Time of day is for normal operation of system and the scheduling of the regeneration time. The date is used in a diagnostic function to track the last time the system regenerated.

HARDNESS

This value is the maximum compensated water hardness in grains per gallon of the raw water supply. It is used to calculate the system capacity. If Ferrous Iron is present add 4 gpg for every 1 ppm of Ferrous Iron.

MANUAL REGENERATION

To start an immediate regeneration select the Manual Regen option. This setting determines the time of day to perform a scheduled regeneration.

DEALER INFORMATION

This is optional. Dealer information can be added.

Canature WaterGroup™ guarantees that your new water conditioner is built of quality material and workmanship. When properly installed and maintained, it will give years of trouble free service.

Seven Year Warranty on 89 Control Valve

Canature WaterGroup™ will repair or replace the failed control valve with reburbished valve for 7 years provided the failure is due to a defect in material or workmanship and not the result of damage from any conditions described in the general conditions of this warranty.

Ten Year Limited Warranty on Fiberglass Tank

Canature WaterGroup™ will replace valve parts and the fibreglass mineral tank which has a 10 year warranty, provided the failure is due to a defect in material or workmanship and not the result of damage from any of the conditions described in the general conditions of this warranty.

General Conditions

Damage to any part of this Specialty System as a result of misuse, misapplication, neglect, alteration, accident, installation or operation contrary to our printed instructions, or damage caused by any force of nature is not covered in this warranty. Softeners are commonly exposed to high levels of iron, manganese, sulphur, and sediment. Damage to pistons, seals, and or spacers within the control valve are not covered in this warranty due to harsh environment. We will repair or replace defective parts if our warranty department determines it to be defective under the terms of this warranty. Canature WaterGroup™ assumes no responsibility for consequential damage, labour or expense incurred as a result of a defect or failure.

In the U.S.A. 1-877-288-9888

In Canada 1-877-288-9888

Regina, SK • Cambridge, ON • Carmel, IN • Fridley, MN • Phoenix, AZ • Pottstown, PA