

565HEDP

DUAL PASS Hardness Reduction System

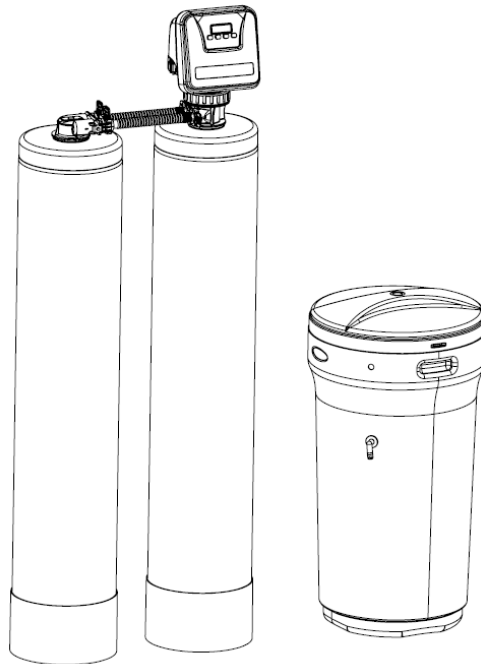

Owners Manual

New Style Parallel Tank Connector

1. Read all instructions carefully before operation.
2. Avoid pinched o-rings during installation by applying (provided with install kit) NSF certified lubricant to all seals.
3. This system is not intended for treating water that is microbiologically unsafe or of unknown quality without adequate disinfection before or after the system.

REVISION # 0
REVISION DATE May 16,2017
54609-1

Canadian Head Office
655 Park St.
Regina, SK S4N 5N1

Table of Contents

	PAGE
Unpacking / Inspection	2
Safety Guide	2
Proper Installation	3
Specification	4
Before Starting Installation	4
Installation Instructions	6
System Start Up	8
Programming Instructions	9
About The System	10
Maintenance	12
Sanitizing Procedure	15
Main Repair Parts	16
Trouble Shooting	23
Warranty	24

Unpacking / Inspection

Be sure to check the entire softener for any shipping damage or parts loss. Also note damage to the shipping cartons. Contact the transportation company for all damage and loss claims. The manufacturer is not responsible for damages in transit.

Small parts, needed to install the softener, are in a parts bag. To avoid loss of the small parts, keep them in the parts bag until you are ready to use them.

Safety Guide

For your safety, the information in this manual must be followed to minimize the risk of electric shock, property damage or personal injury.

- Check and comply with your provincial / state and local codes. You must follow these guidelines.
- Use care when handling the water softening system. Do not turn upside down, drop, drag or set on sharp protrusions.
- The water softening system works on 12 volt-60 Hz electrical power only. Be sure to use only the included transformer.
- Transformer must be plugged into an indoor 120 volt, grounded outlet only.
- Use clean water softening salts only, at least 99.5% pure. NUGGET, PELLET or coarse SOLAR salts are recommended. Do not use rock, block, granulated or ice cream making salts. They contain dirt and sediments, or mush and cake, and will create maintenance problems.
- Keep the salt lid in place on the softener unless servicing the unit or refilling with salt.
- **WARNING:** This system is not intended for treating water that is microbiologically unsafe or of unknown quality without adequate disinfection before or after the system.

Proper Installation

This water softening system must be properly installed and located in accordance with the Installation Instructions before it is used.

- **Do not** install or store where it will not be exposed to temperatures below freezing or exposed to any type of weather. Water freezing in the system will break it. Do not attempt to treat water over 100°F.
- **Do not** install in direct sunlight. Excessive sun or heat may cause distortion or other damage to non-metallic parts.
- Properly ground to conform with all governing codes and ordinances.
- Use only *lead-free solder and flux* for all sweat-solder connections, as required by state and federal codes.
- Maximum allowable inlet water pressure is 125 psi. If daytime pressure is over 80 psi, night time pressure may exceed the maximum. Use a pressure reducing valve to reduce the flow if necessary.
- Softener resins may degrade in the presence of chlorine above 2 ppm. If you have chlorine in excess of this amount, you may experience reduced life of the resin. In these conditions, you may wish to consider purchasing a whole house carbon filter softener system with a chlorine reducing media.
- **WARNING:** Discard all unused parts and packaging material after installation. Small parts remaining after the installation could be a choke hazard.

	A	B	C
1044	51.78"	58.36"	20.71"
1054	61.78"	68.36"	20.71"
1252	59.78"	66.36"	24.57"

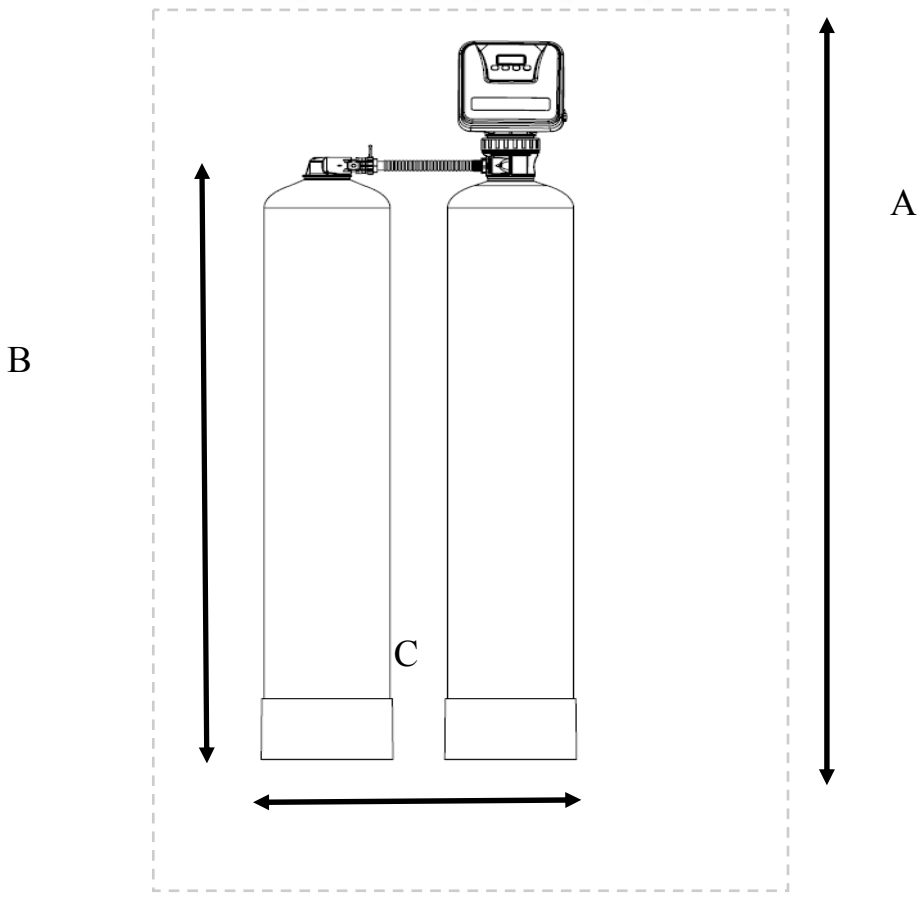

Specifications

Specifications	565HEDP-100	565HEDP-150	565HEDP-200	565HEDP-250
Factory Settings				
Salt Used - Per Regeneration	12.0 lbs	18.0 lbs	24.0 lbs	30.0 lbs
Water Used - Regeneration	86.4 gal	148 gal	162.4 gal	224.8 gal
Hardness Removal - Grains	50,000	75,000	100,000	125,000
Tank #1 Resin Quantity - Cubic Feet	1.0 ft³	1.50 ft³	2.0 ft³	2.5 ft³
Tank #2 Resin Quantity - Cubic Feet	1.0 ft³	1.50 ft³	2.0 ft³	2.5 ft³
Tank Size	9x48	10x54	12x52	13x54
Tank Jacket / Media Loaded	Yes	Yes	No	No
Brine Tank / Cabinet Size (Inches)	20.3 x 37.4	23.0 x 40.5	23.0 x 40.5	23.0 x 40.5
Salt Storage Capacity	350 lbs	420 lbs	420 lbs	420 lbs
Flow Rate @ 15 psi Pressure Drop	7.2 gpm	7.4 gpm	9.0 gpm	9.2 gpm
Flow Rate @ 25 psi Pressure Drop	10.0 gpm	10.1 gpm	11.9 gpm	12.1 gpm
Back Wash Flow Rate	2.0 gpm	2.4 gpm	3.5 gpm	4.0 gpm
Shipping Weight	184 lbs	201 lbs	244 lbs	262 lbs
Regeneration Type	<i>Counter Current / Up Flow</i>			
Plumbing Connections	<i>3/4" (Optional 1")</i>			
Resin Type	<i>Canature 8% High Capacity Ion Exchange Resin</i>			
Electrical Requirements	<i>Input 120V 60 Hz - Output 12V 650mA</i>			
Water Temperature	<i>Min 39 - Max. 100 degrees Fahrenheit</i>			
Water Pressure	<i>Min. 20 - Max. 125 psi</i>			

- Continuous operation at flow rates greater than the service flow rate may affect capacity and efficiency performance.
- The manufacturer reserves the right to make product improvements which may deviate from the specifications and descriptions stated herein, without obligation to change previously manufactured products or to note the change.
- * Models are not tested or certified by WQA

Before Starting Installation

Tools, Pipe, and Fittings, Other Materials

- Pliers
- Screwdriver
- Teflon tape
- Razor knife
- Two adjustable wrenches
- Additional tools may be required if modification to home plumbing is required.
- Plastic inlet and outlet fittings are included with the softener. To maintain full valve flow, 3/4" or 1" pipes to and from the softener fittings are recommended. You should maintain the same, or larger, pipe size as the water supply pipe, up to the softener inlet and outlet.
- Use copper, brass, or PEX pipe and fittings.
- Some codes may also allow PVC plastic pipe.
- ALWAYS install the included bypass valve, or 3 shut-off valves. Bypass valves let you turn off water to the softener for repairs if needed, but still have water in the house pipes.
- 5/8" OD drain line is needed for the valve drain. A 10' length of hose is included with some models.
- A length of 5/8" OD drain line tubing is needed for the brine tank over flow fitting (optional).
- Nugget or pellet water softener salt is needed to fill the cabinet or brine tank.

Where To Install The Softener

- Place the softener as close as possible to the pressure tank (well system) or water meter (city water).
- Place the softener as close as possible to a floor drain, or other acceptable drain point (laundry tub, sump, standpipe, etc.).
- Connect the softener to the main water supply pipe BEFORE the water heater. **DO NOT RUN HOT WATER THROUGH THE SOFTENER.** Temperature of water passing through the softener must be less than 100 deg. F.
- Keep outside faucets on hard water to save soft water and salt.
- Do not install the softener in a place where it could freeze. **Damage caused by freezing is not covered by the warranty.**
- Put the softener in a place water damage is least likely to occur if a leak develops. The manufacturer will not repair or pay for water damage.
- A 120 volt electric outlet, to plug the included transformer into, is needed within 6 feet of the softener. The transformer has an attached 6 foot power cable. **Be sure the electric outlet and transformer are in an inside location, to protect from wet weather.**
- If installing in an outside location, you must take the steps necessary to assure the softener, installation plumbing, wiring, etc., are as well protected from the elements, contamination, vandalism, etc., as when installed indoors.
- **Keep the softener out of direct sunlight.** The sun's heat may soften and distort plastic parts.

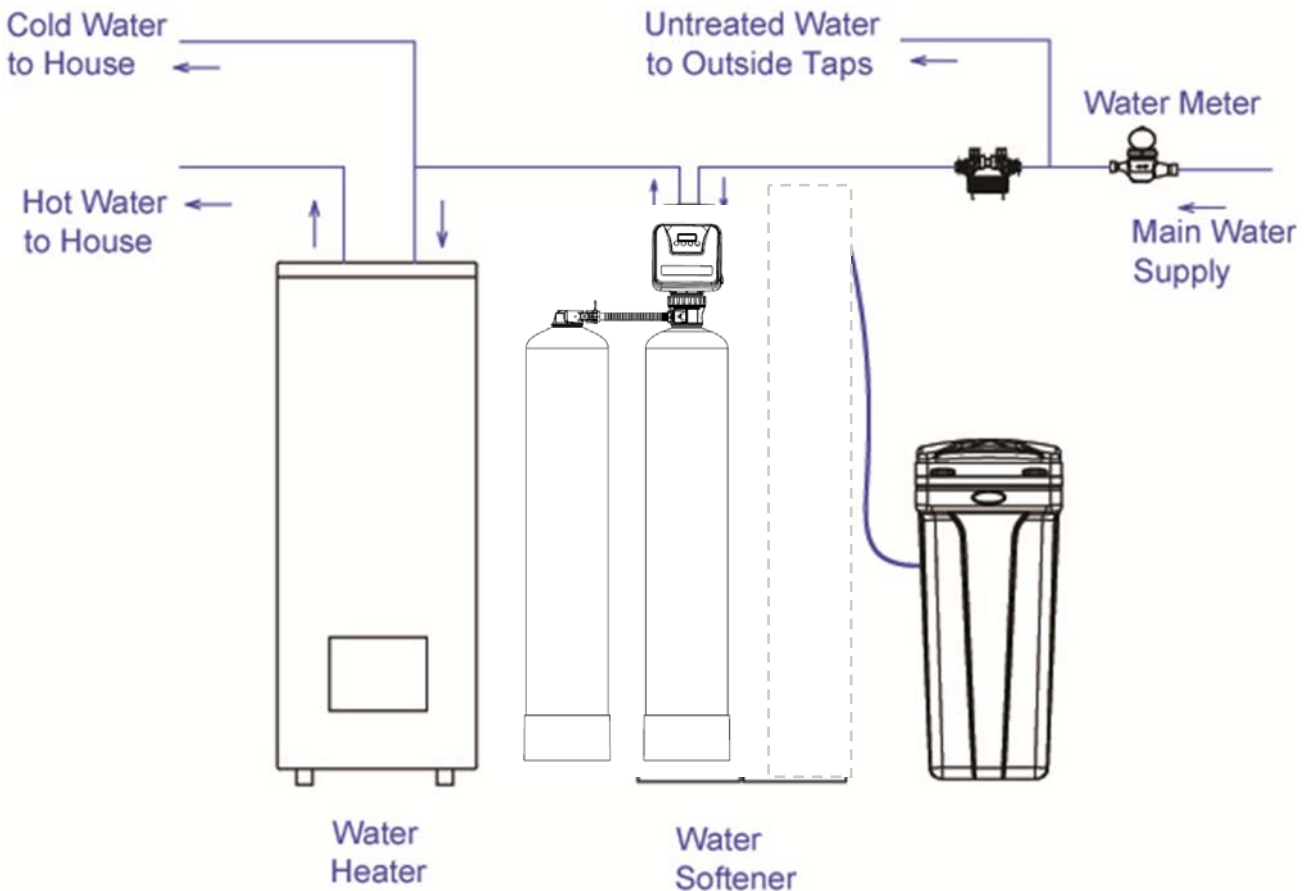

Installation Instructions

1. If your hot water tank is electric, turn off the power to it to avoid damage to the element in the tank.
2. If you have a private well, turn the power off to the pump and then shut off the main water shut off valve. If you have municipal water, simply shut off the main valve. Go to the faucet, (preferably on the lowest floor of the house) turn on the cold water until all pressure is relieved and the flow of water stops.
3. Locate the softener tank and brine tank close to a drain where the system will be installed. The surface should be clean and level.
4. Connect the inlet and outlet of the softener using appropriate fittings. Perform all plumbing according to local plumbing codes.
 - Use a ½" minimum pipe or tubing size for the drain line
 - **ON COPPER PLUMBING SYSTEMS BE SURE TO INSTALL A GROUNDING WIRE BETWEEN THE INLET AND OUTLET PIPING TO MAINTAIN GROUNDING.**

Any solder joints near the valve must be done before connecting any piping to the valve. Always leave at least 6" (152 mm) between the valve and joints when soldering pipes that are connected to the valve. Failure to do this could cause damage to the valve.

5. Connect the drain hose (10 ft included) to the valve and secure it with a hose clamp (also included). Run the drain hose to the nearest laundry tub or drain pipe. This can be ran up overhead or down along the floor. If running the drain line more than 20 ft overhead, it is recommended to increase the hose size to 3/4". NEVER MAKE A DIRECT CONNECTION INTO A WASTE DRAIN. A PHYSICAL AIR GAP OF AT LEAST 1.5" SHOULD BE USED TO AVOID BACTERIA AND WASTEWATER TRAVELLING BACK THROUGH THE DRAIN LINE INTO THE SOFTENER.
6. Using the Allen Key (included), place the unit in the bypass position. Slowly turn on the main water supply. At the nearest cold treated water tap nearby remove the faucet screen, open the faucet and let water run a few minutes or until the system is free of any air or foreign material resulting from the plumbing work.
7. Make sure there are no leaks in the plumbing system before proceeding. Close the water tap when water runs clean.
8. Open the brine tank / cabinet salt lid and add water until there is approximately 3" (75 mm) of water in the tank. Do not add salt to the brine tank at this time.
9. Proceed to start up instructions.

Note: *The unit is not ready for service until you complete the start-up instructions.*

Installation

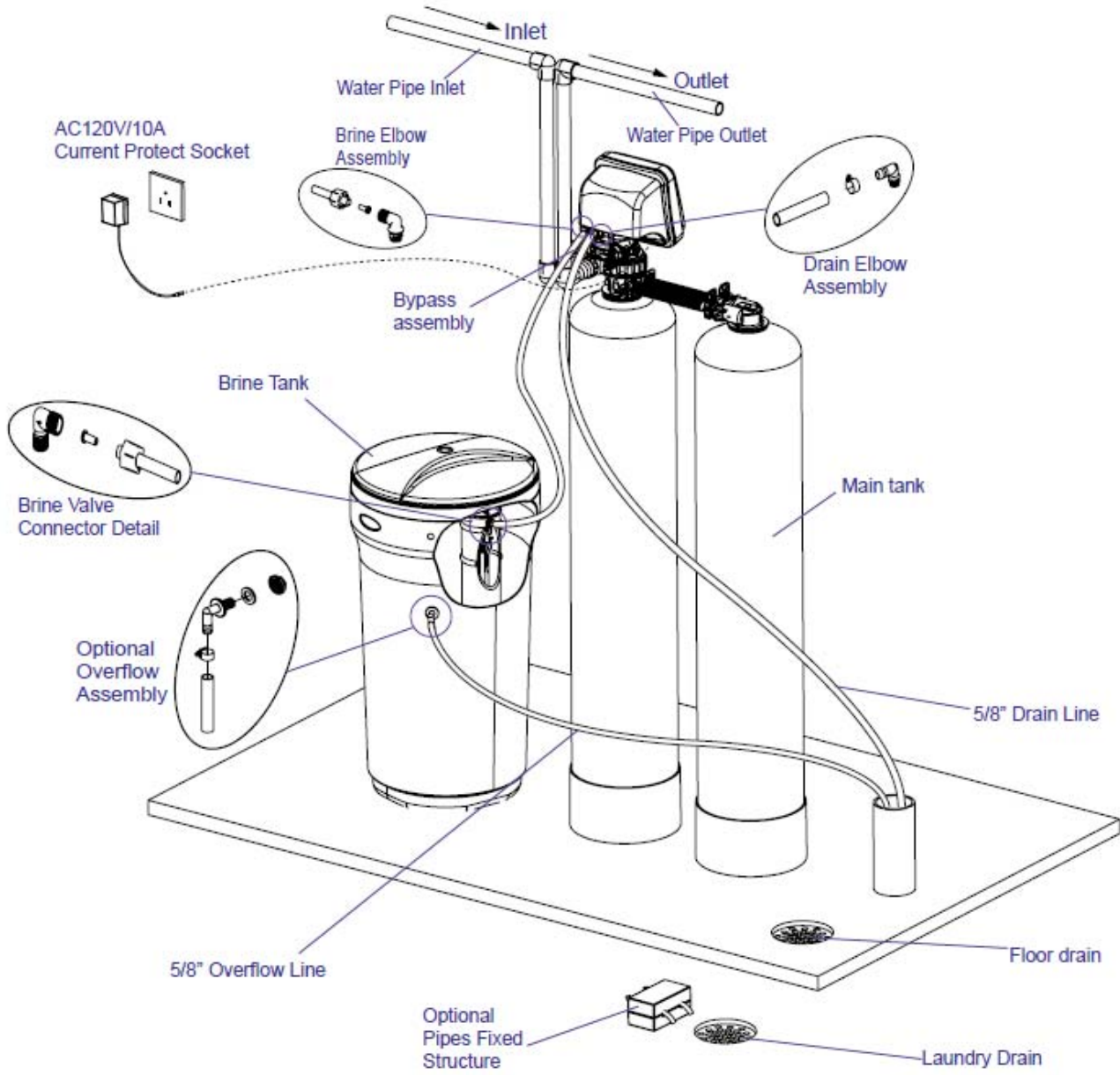

System Start-Up

Key Pad Configuration

SETTINGS	This function is to enter the basic set up information required at the time of installation.
MANUAL REGEN	This function is to initiate an immediate or delayed manual regeneration.
DOWN / UP	Increase or decrease the value of the settings while in the programming mode.

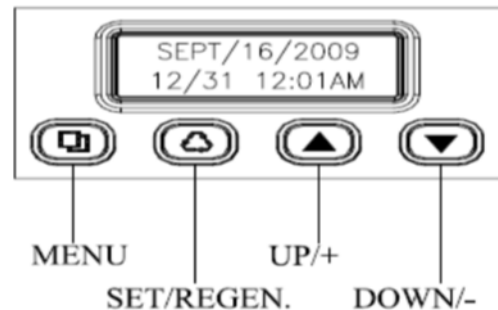

Manual Regeneration (Step / Cycle Valve)

DELAYED REGENERATION

Press and release the MANUAL REGEN. Button to set a delayed regeneration that will occur at the regeneration time. The main display page will show DELAYED REGEN ON. To cancel press and release the MANUAL REGEN. Button. The main display page will show DELAYED REGEN OFF.

IMMEDIATE REGENERATION













To start an immediate regeneration (or step valve through each position), press and hold the MANUAL REGEN. Button for 3 seconds (until beeps). The valve will start an immediate regeneration. Press any key to skip to the next cycle.

Start-up Instructions



1. Plug the power transformer into an approved power source. Connect the power cord to the valve.
2. When power is supplied to the control, the screen will display "INITIALIZING WAIT PLEASE" while it finds the service position.
3. Manually step the valve past the BRINE position to the BACKWASH position. If screen is locked, press SETTINGS for 3 seconds to unlock. Press and hold the MANUL REGEN. Key for 3 seconds. Press any key to skip the BRINE cycle.
4. Once in the BACKWASH cycle, open the inlet on the bypass valve slowly and allow water to enter the unit. Allow all air to escape from the unit before turning the water on fully then allow water to run to drain for 3-4 minutes or until all media fines are washed out of the softener indicated by clear water in the drain hose.
5. Press any button to advance to the RINSE position. Check the drain line flow. Allow the water to run for 3-4 minutes or until the water is clear.
6. Press any button to advance to the REFILL position. Check that the valve is filling water into the brine tank. Allow the valve to refill for the full amount of time as displayed on the screen to insure a proper brine solution for the next regeneration.
7. The valve will automatically advance to the SERVICE position. Open the outlet valve on the bypass, then open the nearest treated water faucet and allow the water to run until clear, close the tap and replace the faucet screen.
8. Add salt into the cabinet / brine tank.
9. Program unit.

Level I User Programming



Setting Current Time

1. If screen is locked, press “ MENU” for 3 seconds to unlock. Press “ MENU” again to enter level one programming mode and adjust CURRENT TIME.
2. Press “ SET/REGEN” to adjust hours. When you have entered the change value mode, the cursor will blink. Press “ or  UP OR DOWN” arrows to change the hour values. Press “ SET/REGEN” again to accept the hour value and advance to change the minutes value. Press “ or  UP OR DOWN” arrows to change the minute values. Press “ SET/REGEN” again to accept the minute values and advance to adjust the AM/PM values. Press “ or  UP OR DOWN” to change the AM/PM value. Press “ SET/REGEN” again to accept the AM/PM value and exit. When you have exited the change value mode, the cursor will stop flashing.





Setting Current Date

1. Press “ DOWN” to advance to CURRENT DATE.
2. Using the same procedure as setting the time, press “ SET/REGEN” to enter value change mode.





Setting Number of People

1. Press “ DOWN” to advance to NUMBER OF PEOPLE.
2. Press the “ SET/REGEN” to change the value. Press up or down arrows to change the values.

Setting Water Hardness

1. Press “ DOWN” to advance to WATER HARDNESS.
2. Press the “ SET/REGEN” to change the value. Press “ or  UP OR DOWN” to change the values.

Setting Vacation Mode



1. Press “ DOWN” to advance to VACATION MODE.
2. Press the “ SET/REGEN” to change the value. Press “ or  UP OR DOWN” to change the values.

Exiting Level One User Program Mode

At any time, press the “ MENU” to accept all changes and return to main page display.

Level I User Program Mode		
PARAMETER	OPTIONS	DESCRIPTION
1	CURRENT TIME	This option is the current time of day.
2	CURRENT DATE	This option is the current date. The date is used to track the last time the system regenerated.
3	NUMBER PEOPLE	This value is the number of people living in the home. It is used to calculate the amount of water needed for daily use and the reserve capacity of the system.
4	WATER HARDNESS	This value is the maximum water hardness in grains per gallon of the raw water supply. It is used to calculate the system capacity.
5	Yes	This function may be activated by the user during a prolonged absence such as vacation. The system will perform a brief backwash and rinse based on the advanced setting. The purpose is to keep the water fresh in the softener tank and plumbing system.
	No	

Start-Up Instructions

1. Plug the valve into an approved power source.
2. When power is supplied to the control, the screen will display “INITIALIZING WAIT PLEASE” while it finds the service position.
3. If screen is locked, press “ MENU” for 3 seconds to unlock. Press “ SET/REGEN” and hold for 3 seconds to initiate a manual regeneration and advance the valve to the Backwash position. Open the inlet on the bypass valve slowly and allow water to enter the unit. Allow all air to escape from the unit before turning the water on fully then allow water to run to drain for 3-4 minutes or until all media fines are washed out of the softener.
4. Press any button to advance to the BRINE position. Check the water level in the brine tank to insure the valve is drawing brine properly.
5. Press any button to advance to the RINSE position. Check the drain line flow. Allow the water to run for 3-4 minutes or until the water is clear.
6. Press any button to advance to the REFILL position. Check that the valve is filling water into the brine tank. Allow the valve to refill for the correct amount of time as displayed on the screen to insure a proper brine solution for the next regeneration.
7. Press any button to advance to the SERVICE position. Open the outlet valve on the bypass, then open the nearest treated water faucet and allow the water to run until clear, close the tap and replace the faucet screen.
8. Add salt into the brine tank.
9. Program hardness and people into controller using Level One Programming Instructions.

The regeneration cycle can last 30 to 180 minutes, after which soft water service will be restored. During regeneration, hard water is automatically bypassed for use in the household. Hot water should be used as little as possible during this time to prevent hard water from filling the water heater. This is why automatic regeneration is set for sometime during the night and manual regenerations should be performed when little or no water will be used in the household.

Normal regeneration time is 2:00 AM.

System Configuration

785 UPFLOW System Configuration			
Tank Size (Diameter)	Injector Set	Brine Line Flow Control (BLFC)	Drain Line Flow Control (DLFC)
8"	#0000 Black	0.20 GPM	#1 (1.5 GPM)
9"			#2 (2.0 GPM)
10"			#3 (2.4 GPM)
12"	#00 Purple		#5 (3.5 GPM)
13"	#0 Red		#6 (4.0 GPM)
14"	#1 WHITE		#A (5.0 GPM)

Manual Bypass

In the case of emergency, such as an overflowing brine tank, you can isolate your water softener from the water supply using the bypass valve located at the back of the control. In normal operation the bypass is open with the on/off knobs in line with the inlet and outlet pipes.

To isolate the softener, simply rotate the knobs clockwise (as indicated by the word BYPASS and arrow) until they lock. You can use your water related fixtures and appliances as the water supply is bypassing the softener. However, the water you use will be hard. To resume soft water service, open bypass valve by rotating the knobs counterclockwise.

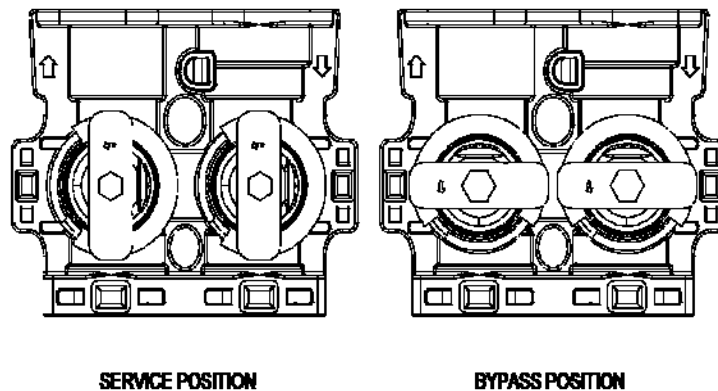

Maintenance

Adding Salt

Use only crystal water softener salt. Check the salt level monthly. It is important to maintain the salt level above the water level. To add salt, simply lift the salt lid and add the salt directly into the brine tank. Be sure the brine well cover is on and fill only to the height of the brine well.

Bridging

Humidity or wrong type of salt may create a cavity between the water and the salt. This action, known as "bridging", prevents the brine solution from being made, leading to your water supply being hard.

If you suspect salt bridging, carefully pound on the outside of the brine tank or pour some warm water over the salt to break up the bridge. This should always be followed up by allowing the unit to use up any remaining salt and then thoroughly cleaning out the brine tank. Allow two hours to produce a brine solution, then manually regenerate the softener.

Cleaning or Replacing Injectors

Sediment, salt and silt will restrict or clog the injector. A clean water supply and pure salt will prevent this from happening.

The injector assembly is located on the right side of the control valve. This assembly is easy to clean.

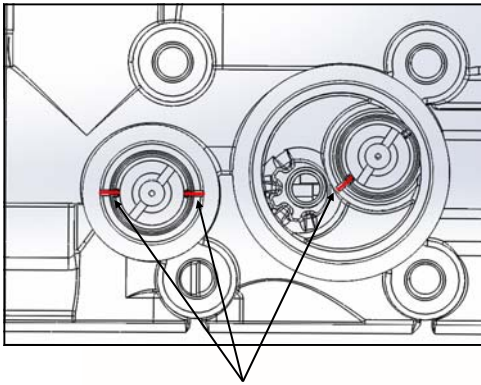

TIP: There are marks on the injector holder that must be lined up to the marks on the valve to fully insert the holder into the hole in the valve body

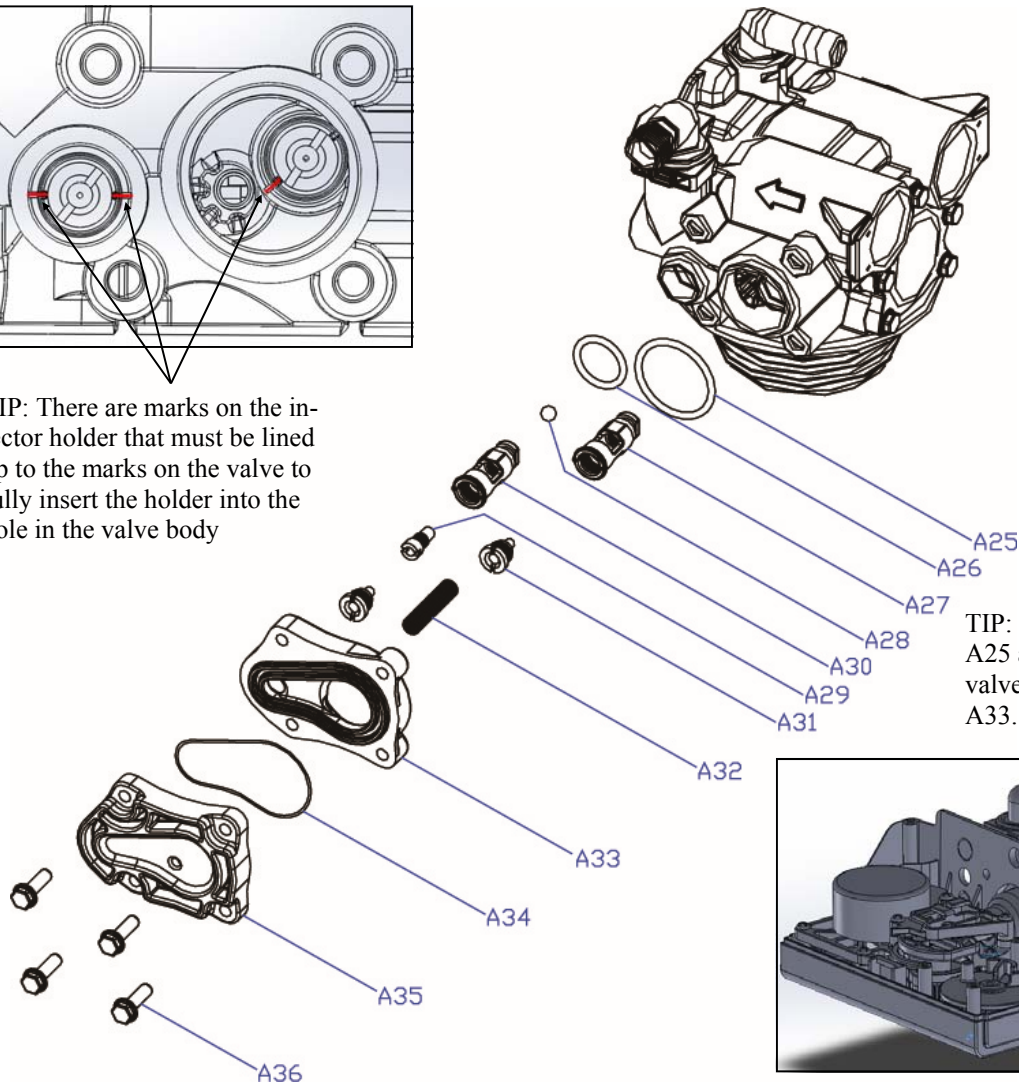

TIP: Place the o-rings A25 and A26 onto the valve before installing A33.

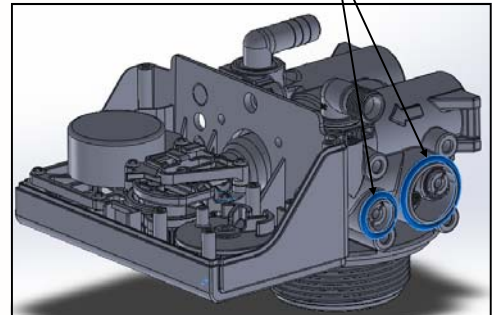

1. Shut off the water supply to your softener and reduce the pressure by opening a cold soft water faucet.
2. Using a screwdriver, remove the four screws holding the injector cover to the control valve body.
3. Carefully remove the assembly and disassemble as shown in above figure.
4. The injector orifice is removed from the valve body by carefully turning it out with a large screwdriver. Remove the injector throat the same way.
5. Carefully flush all parts including the screen. Use a mild acid such as vinegar or Pro-Rust Out to clean the small holes in the orifice and throat.
6. Reassemble using the reverse procedure.

New Style Parallel Tank Connector

14

The design of the parallel tank adaptor used in our dual-tank products (i.e. BIF/BAF, HTO, HEDP etc.) has been redeveloped. This new shorter version will also change the



New flow directions.

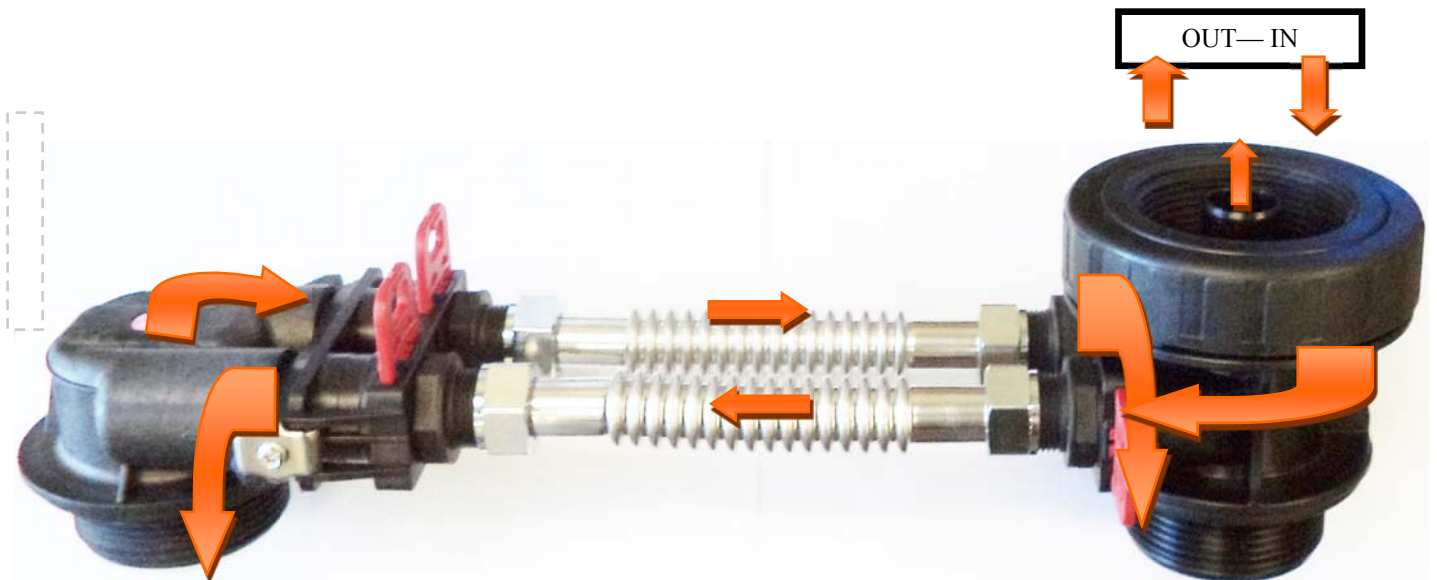

Regeneration Process Explained

Backwash: Backwash: During the backwash cycle, water enters tank #2 through the center of the distribution tube and flows up-wards in the tank#2 expanding the media bed and carrying any precipitated contaminants trapped within the bed. It then travels to tank #1 through the center of the distribution tube and flow upwards in tank #1 and then out to the drain.

Brine Draw: During the brine draw cycle, brine water enters tank #2 through the center of the distribution tube and flows upwards in the tank #2 regenerating the media bed. It then travels to tank #1 through the center of the distribution tube and flows upwards in tank #1 and then out to the drain.

Settle Rinse : During the settle rinse cycle, water enters tank #1 down through the bed and up the through the center of the distribution tube. It then travels to tank #2 down through the bed and up the through the center of the distribution tube and out to the drain.

Refill : During refill the control valve will put water into the brine tank for the next regeneration cycle.

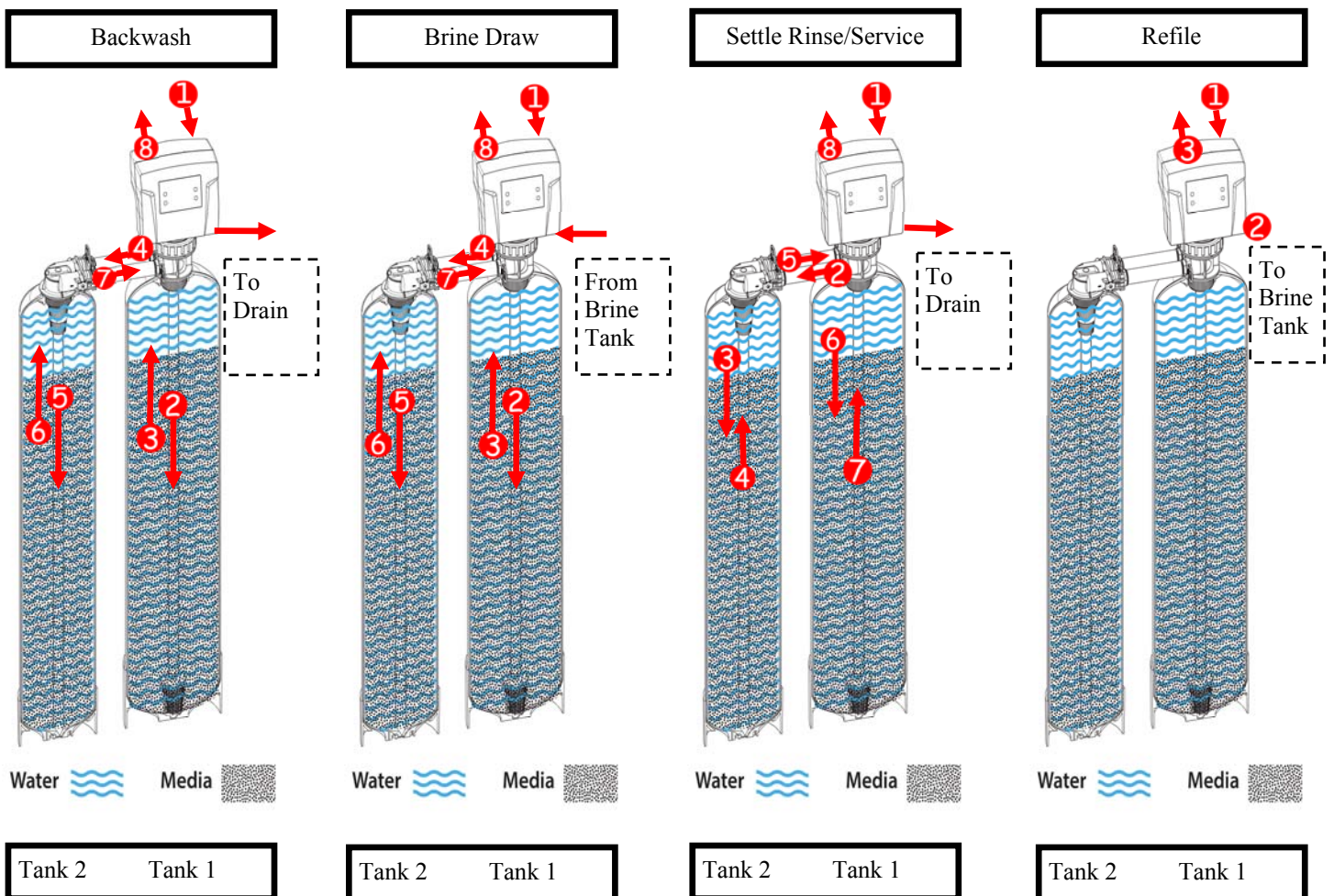

Replacing Brine Line Flow Control (BLFC)

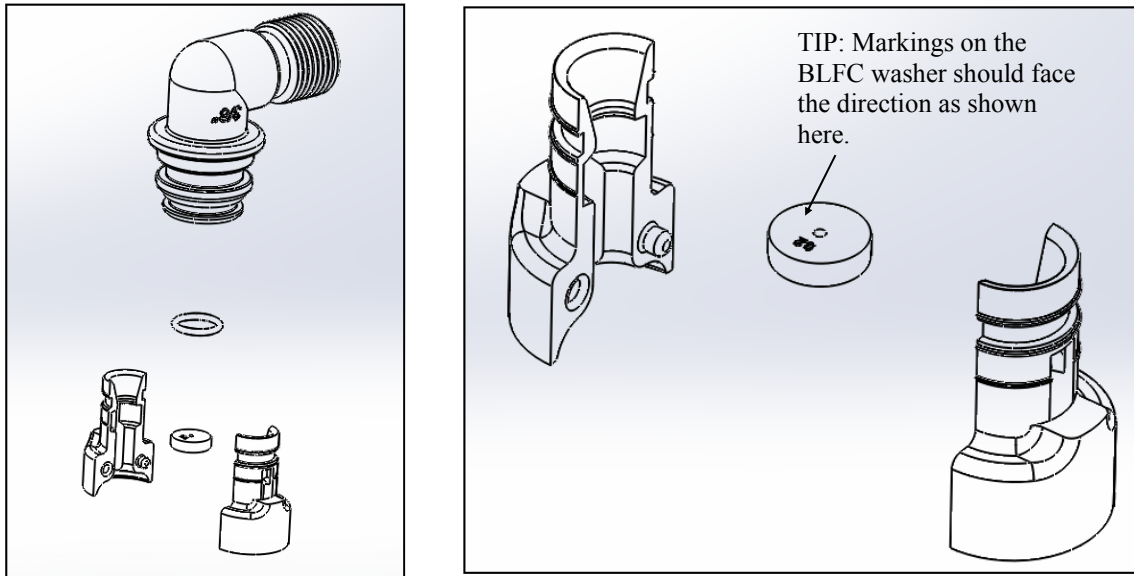

1. Remove the red clip that secures the brine elbow.
2. Remove the BLFC holder from the elbow fitting.
3. Split the BLFC holder apart and remove the flow washer.
4. Reassemble using the reverse procedure.

Replacing Drain Line Flow Control (DLFC)

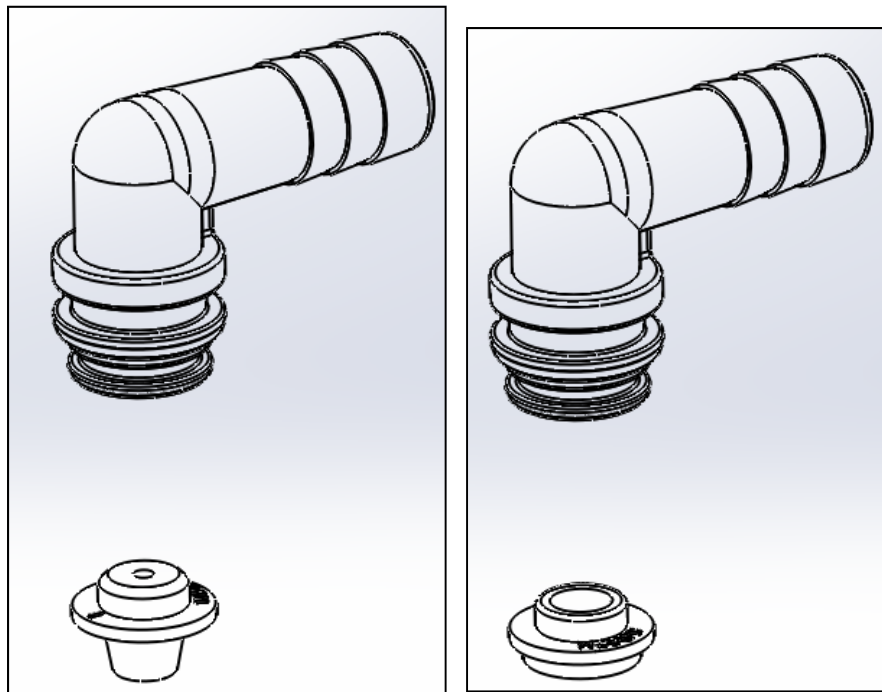

1. Remove the red clip that secures the drain line elbow.
2. Remove the BLFC washer from the elbow fitting.
3. Reassemble using the reverse procedure.

Care of Your System

To retain the attractive appearance of your new water softener, clean occasionally with mild soap solution. Do not use abrasive cleaners, ammonia or solvents. Never subject your softener to freezing or to temperatures above 100°F.

Resin Cleaner

An approved resin cleaner must be used on a regular basis if your water supply contains iron. The amount of resin cleaner and frequency of use is determined by the quantity of iron in your water (consult your local representative or follow the directions on the resin cleaner package).



Item #	Description
80030006	Res Care - 1 gal. Bottle
80030005	Res Care - 1 qt. Bottle



Item #	Description
80030002	Rust Out - 1.5 lb. Bottle
80030003	Rust Out - 5 lb. Bottle
80030004	Rust Out - 50 lb. Pail



Item #	Description
55030001	Res Up Feeder - 0.5 oz/day Feeder
55030002	Res Up Feeder - 1.0 oz/day Feeder

Sanitizing Procedure

Care is taken at the factory to keep your water softener clean and sanitary. Materials used to make the softener will not infect or contaminate your water supply, and will not cause bacteria to form or grow. However, during shipping, storage, installing and operating, bacteria could get into the softener. For this reason, sanitizing as follows is suggested when installing.

Sani-System Liquid Sanitizer Concentrate



Item# 80030021—Softener Sanitizer 0.25 fl.oz (24 Pack)

1. Be sure to complete all installation steps, including programming.
2. For effective and complete sanitization, Sani-System Liquid Sanitizer Concentrate is recommended. Pour one 0.25 fl. Oz. package into the brine well located in the cabinet or brine tank. (Alternative use 3/4 oz of common 5.25% household bleach)
3. Start an immediate regeneration. (See page 11)
4. The Softener Sanitizer Solution is drawn into and through the water softener to sanitize it. This sanitizing regeneration is over in about two hours. Then, **soft water** is available for your use.

NOTE: Sanitizing is recommended by the Water Quality Association for disinfecting. On some water supplies, they suggest periodic sanitizing.

Brine Tank & Res-Up Feeder Assembly (Optional)

Step 1

Install salt plate and align brine well opening with the tank handle.



Step 2

Install feeder bracket into the 2 pre-drilled holes.



Step 3

Install brine well. Feed wick from feeder into the opening in the brine well cap.



Step 4

Push feeder into brine well cap as shown to complete the assembly.



Main Repair Parts - Connectors

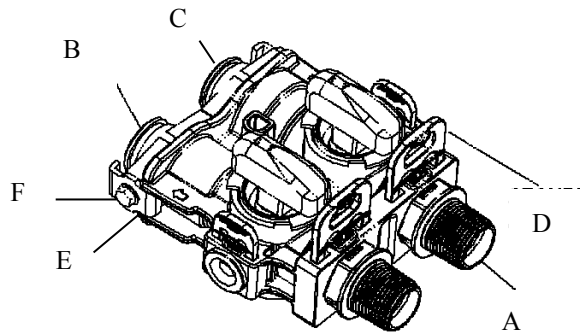
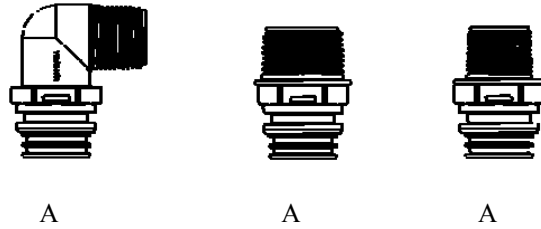

REPLACEMENT PARTS - CONNECTORS			
Replacement Part Number	Part Description	DWG #	Quantity
60010020	3/4" NPT ELBOW	A	2
60010019	1" NPT STRAIGHT	A	2
60010023	3/4" NPT STRAIGHT	A	2
60010079	VALVE COUPLING INLET	B	1
60010101	VALVE COUPLING OUTLET (METER SIDE)	C	1
60010025	PLASTIC SECURE CLIP	D	2
60010046	BYPASS SS CLIP	E	2
60010047	BYPASS SS SCREW	F	2

Control Valve Exploded View

FILTER INJECTOR OPTION

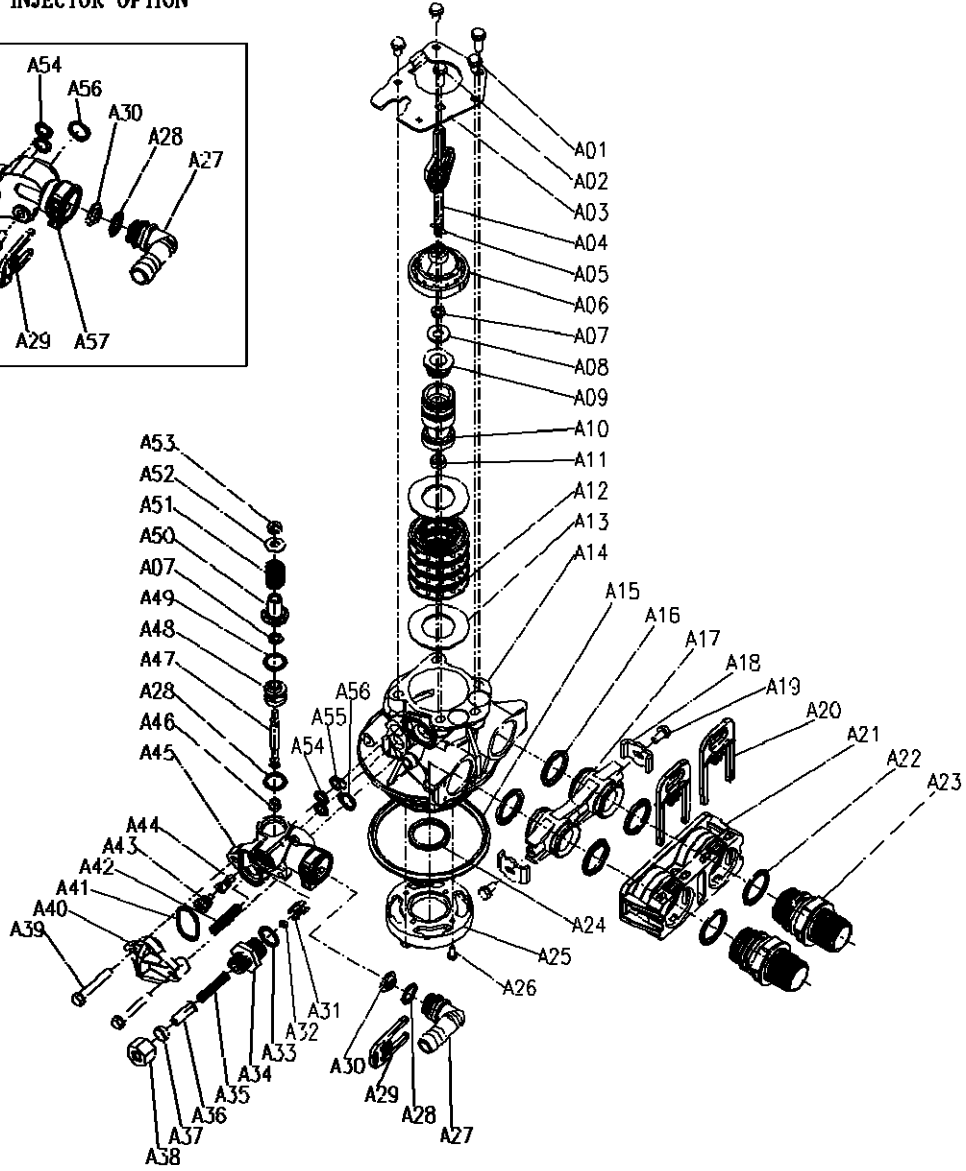
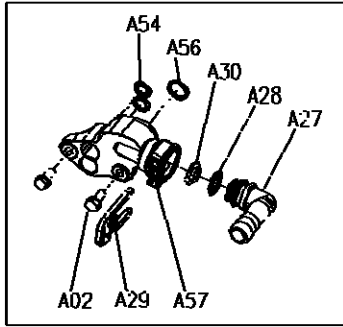

Control Valve Parts List

Item No.	Part No.	Part Discription	Quantity
A01	05056087	Screw-M5×12(Hexagon)	3
A02	05056088	Screw-M5×16(Hexagon with Washer)	2
A03	05056047	End Plug Retainer	1
A04	05010081	Bnt65 Piston Rod	1
A05	05056097	Piston Pin	1
A06	05056023	End Plug	1
A07	05056070	Quad Ring	2
A08	05056024	End Plug Washer	1
A09	05056022	Piston Retainer	1
A10	05056181	Piston (Electrical)	1
A11	05056104	Muffler	1
A12	05056021	Spacer	4
A13	05056073	Seal	5
A14	05056019	Bnt65 Valve Body	1
A15	05056063	O-ring-φ78.74×5.33	1
A16	05056129	O-ring-φ23×3	4
A17	05056025	Adaptor Coupling	2
A18	05056044	Adaptor Clip	2
A19	05056090	Screw-ST4.2×13(Hexagon with Washer)	2
A20	21709003	Secure Clip	2
A21	05056140	Valve Connector	1
A22	05056065	O-ring-φ23.6×2.65	2
A23	21319006	Screw Adaptor	2
A24	26010103	O-ring-φ25×3.55	1
A25	07060007	Valve Bottom Connector	1
A26	13000426	Screw-ST2.9×13(Large Wafer)	2
A27	05010082	Drain Fitting	1
A28	05056134	O-Ring-φ12×2	1
A29	05056172	Secure Clip-S	1
A30	05056186	DLFC-2#	1
A32	05056035	BLFC Button Retainer	1
A33	05056191	BLFC-2#	1
A34	05056138	O-Ring-φ14×1.8	1
A35	05056100B	BLFC Fitting	1
A36	05056106	Brine Line Screen	1
A37	05056107	BLFC Tube Insert	1
A38	05056033	BLFC Ferrule	1
A39	05056108	BLFC Fitting Nut	1
A40	05056086	Screw-M5×30(Hexagon with Washer)	2
A41	05056029	Injector Cover	1
A42	05056072	O-Ring-φ24×2	1
A43	05056103	Injector Screen	1
A44	05056027	Injector Nozzle	1
A45	05056028	Injector Throat	1
A46	05056177	Injector Body	1
A47	05056075	Injector Seat	1
A48	05056134	O-Ring-φ12×2	1
A49	05056054	Injector Stem	1
A50	05056031	Injector Spacer	1
A51	05056081	O-Ring-φ12.5×1.8	1
A52	05056030	Injector Cap	1
A53	05056093	Injector Screen	1
A54	05010049	Special Washer	1
A55	05056105	Retaining Ring	1
A56	05056067	O-Ring-φ7.8×1.9)	2
A57	05056037	Air Disperser	1
A58	05056066	O-Ring-φ11×2	1

Power Head Exploded View

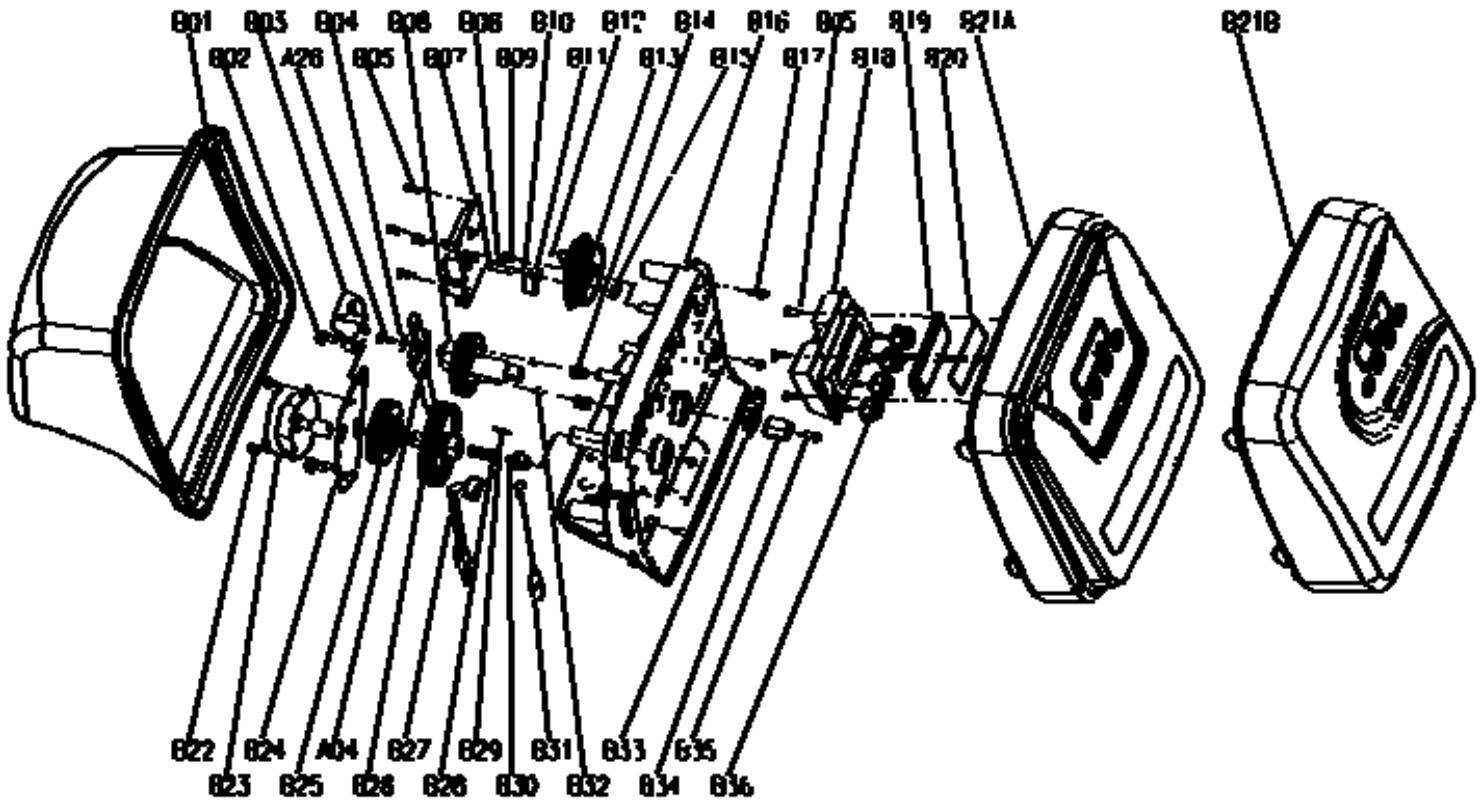

Power Head Parts List

Item No.	PartNo.	Part Description	Quantity	Item No.	Part No.	Part Description	Quantity
B01	05056523	Bnt365 Cover	1	B21A	05056527	Bnt65 Front Cover	1
B02	05056136	Screw-ST3.5X13 (Hexagon with Washer)	2	B21B	05056531	Bnt65 Front Cover	1
B03	05010045	Piston Stem Holder	1	B22	05056082	Screw-M 3X6	2
A26	13000426	Screw-ST2.9X13 (Large Washer)	1	B23	05056510	Motor 12v/2rpm	1
B04	05056139	Washer 3x13	1		05030014	Motor Power Cable	1
B05	05010037	Screw-ST2.9X10	8		11700005	Wire Connector	2
B06	05056005	Main Gear	1	B24	05056045	Motor Mounting Plate	1
B07	05030010	Bnt65 Main Pcb	1	B25	05056501	Drive Gear	1
B08	05056083	Screw-M 4x14	1	A04	05010081	Bnt65 Piston Rod	1
B09	05056166	Screw-ST4.2X12 (Large Washer)	1	B26	05056002	Helix Gear	1
B10	05056141	Washer 4x12	1	B27	05010031	Meter Assembly	1
B11	05056016	Brine Regulator	1		05010046	Meter Sun Relief	1
B12	05010023	Magnet 40X2.7	1	B28	05056094	Spring Helix	1
B13	05056015	Brine Gear	1	B29	05056098	Motor Pin	1
B14	05056095	Spring Detent	2	B30	05056502	Spring Retainer	1
B15	05056089	Nut M 4	1	B31	05010029	Power Cable	1
B16	05056522	Bnt65 Housing	1		05056013	Power Sun Relief	1
B17	05056084	Screw-ST3.5x13	4	B32	05056092	Bal H/4 Inch	2
B18	05030020	Bnt65 Display (NOVO)	1	B33	05056503	Magnet Holder	1
	05056536	Bnt65 Wiring Harness	1	B34	05056554	Locking Knob	1
B19	05056528	Pcb Cover	1	B35	05056561	Screw-ST3.5X15 (CSK)	1
B20	26010047	O-Ring-40X1.8	1	B36	05056529	Bnt65 Button	4

Trouble Shooting

Issue	Possible Cause	Possible Solution
A. Unit fails to initiate a regeneration cycle.	1. No power supply.	Check electrical service, fuse, etc.
	2. Defective circuit board.	Replace faulty parts.
	3. Power failure.	Reset time of day.
	4. Defective meter.	Replace turbine meter.
B. Water is hard.	1. By-pass valve open.	Close by-pass valve.
	2. Out of salt or salt level below water level.	Add salt to tank.
	3. Plugged injector / screen.	Clean parts.
	4. Flow of water blocked to brine tank.	Check brine tank refill rate.
	5. Hard water in hot water tank.	Repeat flushing of hot water tank required.
	6. Leak between valve and central tube.	Check if central tube is cracked or o-ring is damaged. Replace faulty parts.
	7. Internal valve leak.	Replace valve seals, spacer, and piston assembly.
	8. Reserve capacity setting too low.	Increase reserve capacity.
	9. Not enough capacity.	Increase salt dosage.
C. Salt use is high.	1. Refill time is too high.	Check refill time setting.
	2. Defective flow control.	Replace.
D. Low water pressure.	1. Iron or scale build up in line feeding unit.	Clean pipes.
	2. Iron build up inside valve or tank.	Clean control and add resin cleaner to clean bed. Increase regeneration frequency.
	3. Inlet of control plugged due to foreign material.	Remove piston and clean control valve.
	4. Deteriorated resin. (Maybe caused from high chlorine or chloramines.)	Re-bed unit. Consider adding carbon pre-treatment.
E. Resin in drain line.	1. Air in water system.	Check well system for proper air eliminator control.
	2. Incorrect drain line flow control (DLFC) button.	Check for proper flow rate.
F. Too much water in brine tank.	1. Plugged injector or screen.	Clean parts.
	2. Valve not regenerating.	Replace circuit board, motor, or control.
	3. Foreign material in brine valve.	Clean parts.
	4. Unit not drawing brine.	Check for vacuum leak in brine line connections.
G. Unit fails to draw brine.	1. Drain line flow control is plugged.	Clean parts.
	2. Injector or screen is plugged.	Clean parts.
	3. Inlet pressure too low.	Increase pressure to 25 PSI.
	4. Internal valve leak.	Replace seals, spacers, and piston assembly.
	5. Safety valve closed.	Check for leak in brine line connections. Replace safety float assembly.
	6. Vacuum leak in brine line.	Check for leak in brine line connections. Tighten all connections.
	7. Drain line has kink in it or is blocked.	Check drain line.
H. Valve continuously cycles.	1. Defective position sensor PCB.	Replace faulty parts.
I. Flow to drain continuously.	1. Valve settings incorrect.	Check valve settings.
	2. Foreign material in control valve.	Clean control.
	3. Internal leak.	Replace seals, spacers, and piston assembly.
	4. Piston is stuck in position. Motor may have failed or gears have jammed or disengaged.	Check for power to motor. Check for loose wire. Check for jammed gears or gears disengaged. Replace faulty parts.
J. Valve makes beeping sound.	1. The piston has not advanced to the next cycle position properly.	Check for power to motor. Check for loose wire. Check for jammed gears or gears disengaged.

Warranty

Canature WaterGroup warrants that your new water conditioner is built of quality material and workmanship. When properly installed and maintained, it will give years of trouble free service.

Seven Year Complete Parts Guarantee

Canature WaterGroup will replace any part which fails within 84 months from date of manufacture, as indicated by the serial number, provided the failure is due to a defect in material or workmanship. The only exception shall be when proof of purchase or installation is provided and then the warranty period shall be from the date thereof.

Life Time Warranty on Mineral Tanks and Brine Tanks

Canature WaterGroup will provide a replacement mineral tank or brine tank to any original equipment purchaser in possession of a tank that fails provided that the water conditioner is at all times operated in accordance with specifications and not subject to freezing. Warranty does not apply to media beds, seals or pistons worn due to abrasive water conditions.

General Conditions

Damage to any part of this water conditioner or filter as a result of misuse, misapplication, neglect, alteration, accident, installation or operation contrary to our printed instructions, damage to ion exchange resin and seals caused by chlorine / chloramines in the water supply, or damage caused by any force of nature is not covered in this warranty. We will repair or replace defective parts if our warranty department determines it to be defective under the terms of this warranty. Canature assumes no responsibility for consequential damage, labour or expense incurred as a result of a defect or failure.