

565 Valve Filter

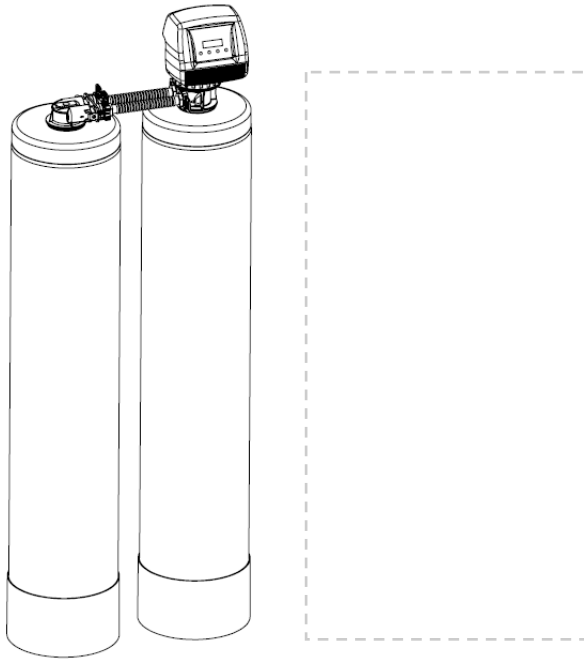

New Style Parallel Tank Connector

FOLLOW THE INSTALLATION INSTRUCTIONS CAREFULLY. FAILURE TO INSTALL THE UNIT PROPERLY VOIDS THE WARRANTY. BEFORE YOU BEGIN INSTALLATION, READ THIS ENTIRE MANUAL. THEN, OBTAIN ALL THE MATERIALS AND TOOLS

1. **Avoid pinched o-rings during installation by applying (provided with install kit) NSF certified lubricant to all seals.**
2. **This system is not intended for treating water that is microbiologically unsafe or of unknown quality without adequate disinfection before or after the system.**
3. **Filters are commonly exposed to high levels of iron, manganese, sulfur, and sediments. Damage to pistons, seals, and or spacers within the control valve are not covered in this warranty due to the harsh environment.**
4. **It is recommended to regularly inspect and service the control valve on an annual basis. Cleaning and or replacement of piston, seals, and or spacers may be necessary depending how harsh the condition are.**

Table of Contents

	PAGE
Unpacking / Inspection	2
Safety Guide	2
Proper Installation	3
Specification	4
Before Starting Installation	4
Sizing Requirement	7
Installation Instructions	8
System Start Up	10
Programming Instructions	11
About The System	12
Maintenance	13
Main Repair Parts	16
Trouble Shooting	21
Warranty	22

Unpacking / Inspection

Be sure to check the entire unit for any shipping damage or parts loss. Also note damage to the shipping cartons. Contact the transportation company for all damage and loss claims. The manufacturer is not responsible for damages in transit.

Small parts, needed to install the softener, are in a parts bag. To avoid loss of the small parts, keep them in the parts bag until you are ready to use them.

Safety Guide

For your safety, the information in this manual must be followed to minimize the risk of electric shock, property damage or personal injury.

- Check and comply with your provincial / state and local codes. You must follow these guidelines.
- Use care when handling the filter tank. Do not turn upside down, drop, drag or set on sharp protrusions.
- The system works on 12 volt-60 Hz electrical power only. Be sure to use only the included transformer.
- Transformer must be plugged into an indoor 120 volt, grounded outlet only.
- **WARNING:** This system is not intended for treating water that is microbiologically unsafe or of unknown quality without adequate disinfection before or after the system.

Proper Installation

This water filter system must be properly installed and located in accordance with the Installation Instructions before it is used.

- **Do not** install or store where it will not be exposed to temperatures below freezing or exposed to any type of weather. Water freezing in the system will break it. Do not attempt to treat water over 100°F.
- **Do not** install in direct sunlight. Excessive sun or heat may cause distortion or other damage to non-metallic parts.
- Properly ground to conform with all governing codes and ordinances.
- Use only *lead-free solder and flux* for all sweat-solder connections, as required by state and federal codes.
- Maximum allowable inlet water pressure is 125 psi. If daytime pressure is over 80 psi, night time pressure may exceed the maximum. Use a pressure reducing valve to reduce the flow if necessary.
- **WARNING:** Discard all unused parts and packaging material after installation. Small parts remaining after the installation could be a choke hazard.

New Style Parallel Tank Connector

The design of the parallel tank adaptor used in our dual-tank products (i.e. BIF/BAF, HTO, HEDP etc.) has been redeveloped. This new shorter version will also change the



New flow directions.

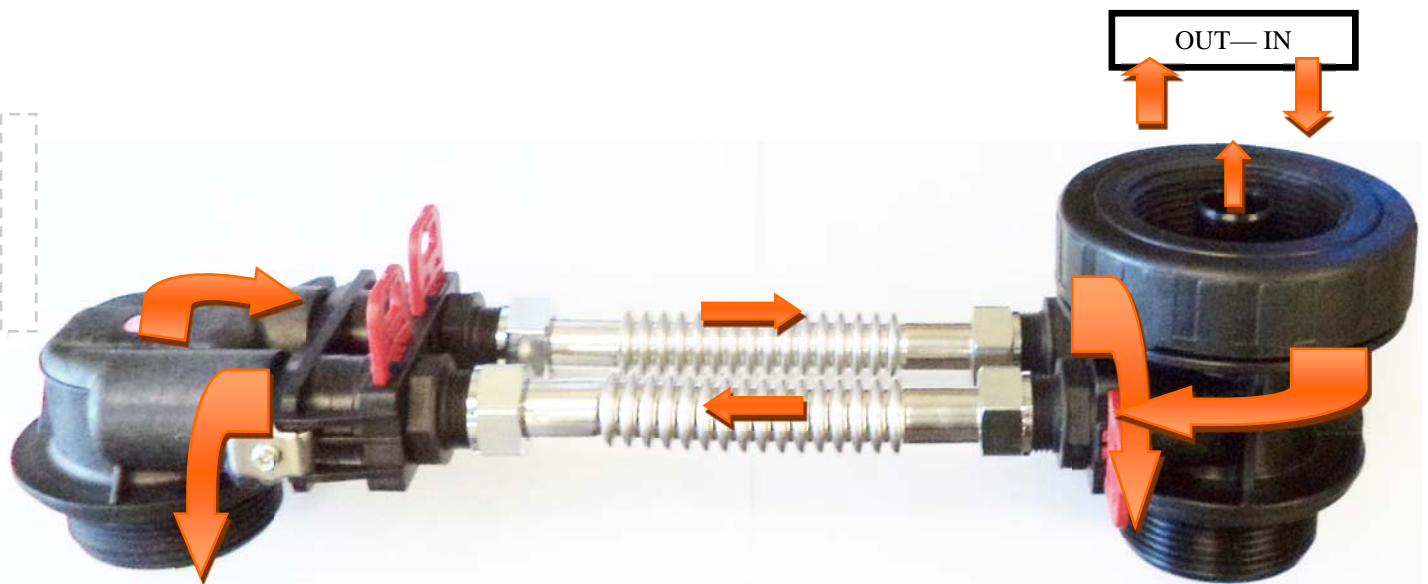

Regeneration Process Explained

Backwash: Backwash: During the backwash cycle, water enters tank #2 through the center of the distribution tube and flows up-wards in the tank#2 expanding the media bed and carrying any precipitated contaminants trapped within the bed. It then travels to tank #1 through the center of the distribution tube and flow upwards in tank #1 and then out to the drain.

Brine Draw: During the brine draw cycle, brine water enters tank #2 through the center of the distribution tube and flows upwards in the tank #2 regenerating the media bed. It then travels to tank #1 through the center of the distribution tube and flows upwards in tank #1 and then out to the drain.

Settle Rinse : During the settle rinse cycle, water enters tank #1 down through the bed and up the through the center of the distribution tube. It then travels to tank #2 down through the bed and up through the center of the distribution tube and out to the drain.

Refill : During refill the control valve will put water into the brine tank for the next regeneration cycle.

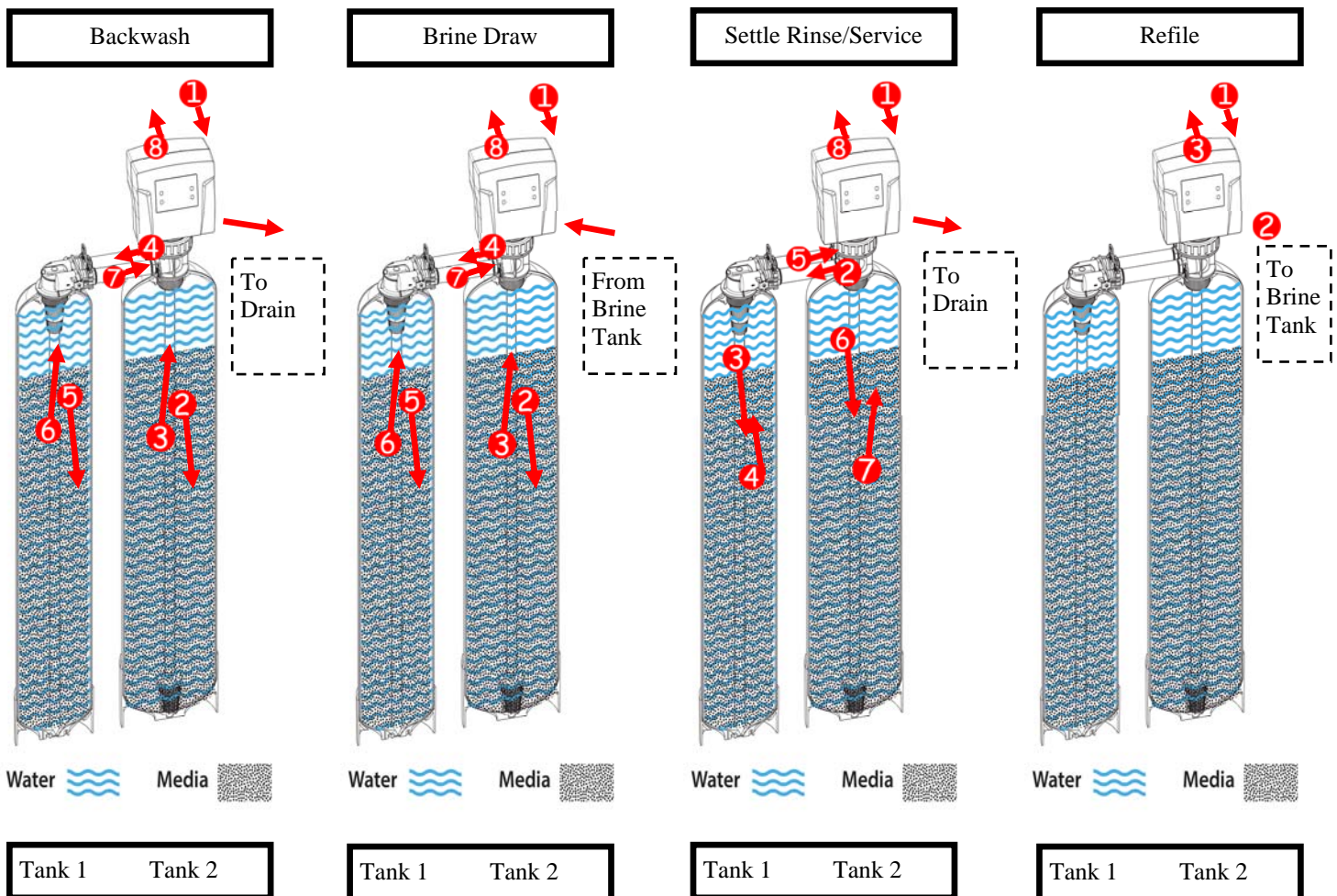

Specifications

How Your Filter Works

Backwashing of the filter takes place during the night while you sleep. First, backwashing cleans the filter bed, then a rapid rinse clears any remaining particulates from the water. All functions are performed automatically.

Your automatic filter can be set to operate according to your needs by programming the appropriate settings. On the days your filter regenerates, the operating cycles will be automatically performed. In the service position, filtered water is supplied for household use. This valve is controlled with simple, user-friendly electronics displayed on a LCD screen. The main page displays the current time and the remaining gallons in meter mode or the remaining days in calendar clock mode.

Before Starting Installation

Tools, Pipe, and Fittings, Other Materials

- Pliers
 - Screwdriver
 - Teflon tape
 - Razor knife
 - Two adjustable wrenches
 - Additional tools may be required if modification to home plumbing is required.
 - Plastic inlet and outlet fittings are included
- with the filter. To maintain full valve flow, 3/4" or 1" pipes to and from the filter fittings are recommended. You should maintain the same, or larger, pipe size as the water supply pipe, up to the softener inlet and outlet.

- Use copper, brass, or PEX pipe and fittings.
- Some codes may also allow PVC plastic pipe.
- ALWAYS install the included bypass valve, or 3 shut-off valves. Bypass valves let you turn off water to the filter for repairs if needed, but still have water in the house pipes.
- 5/8" OD drain line is needed for the valve drain. A 10' length of hose is included with some models.

Where To Install The Filter

- Place the filter tank as close as possible to the pressure tank (well system) or water meter (city water).
- Place the filter tank as close as possible to a floor drain, or other acceptable drain point (laundry tub, sump, standpipe, etc.).
- Connect the filter to the main water supply pipe BEFORE the water heater. **DO NOT RUN HOT WATER THROUGH THE FILTER.** Temperature of water passing through the filter must be less than 100 deg. F.
- Do not install the filter in a place where it could freeze. **Damage caused by freezing is not covered by the warranty.**
- Put the filter in a place water damage is least likely to occur if a leak develops. The manufacturer will not repair or pay for wa-
- ter damage.
- A 120 volt electric outlet, to plug the included transformer into, is needed within 6 feet of the softener. The transformer has an attached 6 foot power cable. Extension cables are available. **Be sure the electric outlet and transformer are in an inside location, to protect from wet weather.**
- If installing in an outside location, you must take the steps necessary to assure the filter, installation plumbing, wiring, etc., are as well protected from the elements, contamination, vandalism, etc., as when installed indoors.
- **Keep the filter out of direct sunlight.** The sun's heat may soften and distort plastic parts.

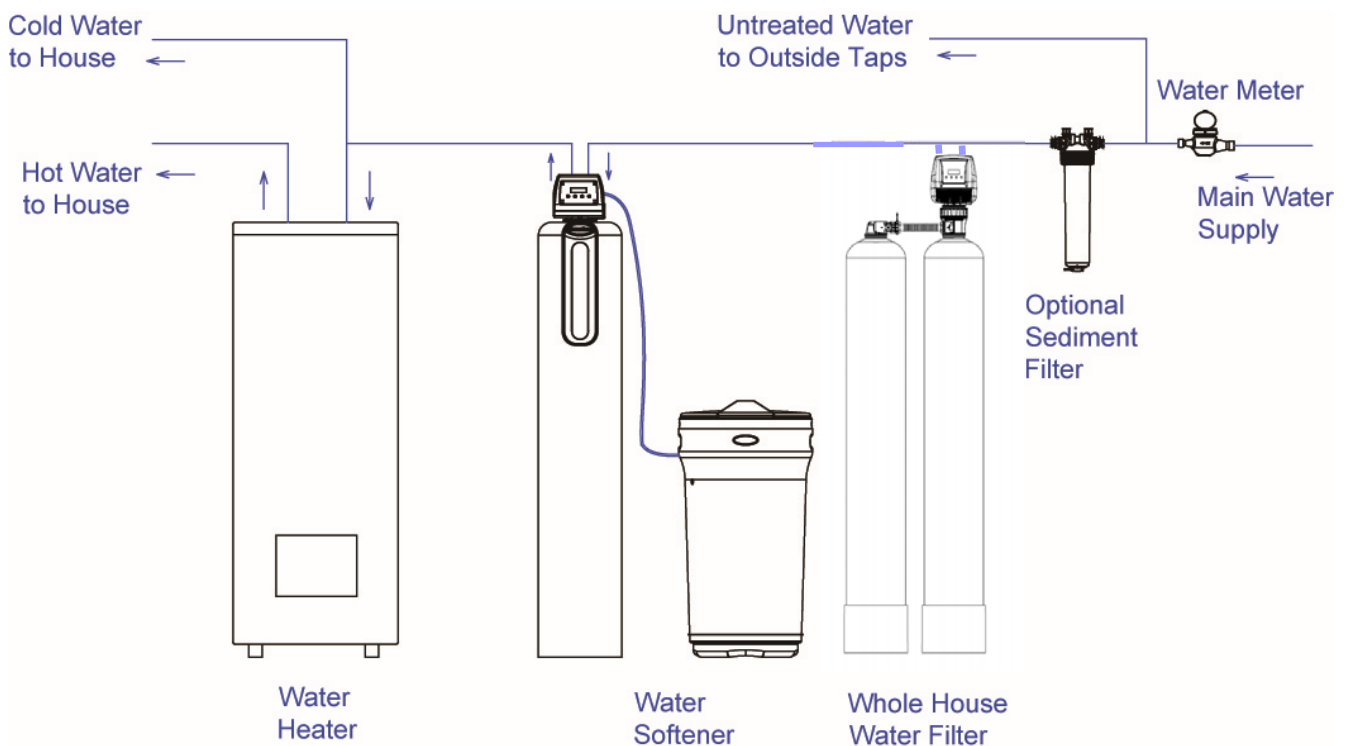

Sizing Requirements

Water Pressure

The water system must have a pump big enough to deliver the recommended backwash rate with a minimum pressure at the inlet of the filter of 30 psi. If the existing system cannot do this, it must be upgraded to do so. Whenever possible, the water system should be adjusted to deliver at least 30 psi for even more satisfactory results.

Backwash Flow Rates

The most important criteria in sizing a filter is the capacity of the pump. The water must pass through the filter media at the proper service flow rate. The filter must also be backwashed at a flow rate sufficient to dislodge and remove the captured particles. Failure to provide sufficient water will cause a build-up of particles in the filter media, impairing its ability. In order for your filter to backwash and rinse properly, your pump must be capable of providing the backwash flow rates indicated on page 4.

Check Your Pumping Rate

Two water system conditions must be checked carefully to avoid unsatisfactory operation or equipment damage:

1. Minimum water pressure required at the filter tank inlet is 20 psi.
2. Measuring the pumping rate of your pump:

With the pressure tank full, draw water into a container of known volume, and measure the number of gallons drawn until the pump starts again. This is draw-down. Divide this figure by cycle time and multiply the result by 60 to arrive at the pumping rate in gallons per minute (gpm). To aid in your calculation, insert the date in the following formula:

DRAW-DOWN _____ ÷ CYCLE TIME _____ x 60 = PUMPING RATE _____ (gals)
(secs.) (Gpm)

EXAMPLE: CYCLE TIME is 53 seconds. DRAW-DOWN is 6 gallons; then, PUMPING RATE equals:

$$6 \text{ gallons} \div 53 \text{ seconds} \times 60 = 6.8 \text{ gpm}$$

See chart on page 4 for minimum flow rates.

NOTE: If your pumping rate is inadequate for the model, do not install your filter until the problem has been corrected.

Installation Instructions

1. If your hot water tank is electric, turn off the power to it to avoid damage to the element in the tank.
2. If you have a private well, turn the power off to the pump and then shut off the main water shut off valve. If you have municipal water, simply shut off the main valve. Go to the faucet, (preferably on the lowest floor of the house) turn on the cold water until all pressure is relieved and the flow of water stops.
3. Locate the filter tank close to a drain where the system will be installed. The surface should be clean and level.
4. Connect the inlet and outlet of the filter using appropriate fittings. Perform all plumbing according to local plumbing codes.
 - Use a ½" minimum pipe or tubing size for the drain line
 - **ON COPPER PLUMBING SYSTEMS BE SURE TO INSTALL A GROUNDING WIRE BETWEEN THE INLET AND OUTLET PIPING TO MAINTAIN GROUNDING.**

Any solder joints near the valve must be done before connecting any piping to the valve. Always leave at least 6" (152 mm) between the valve and joints when soldering pipes that are connected to the valve. Failure to do this could cause damage to the valve.

5. Connect the drain hose (10 ft included) to the valve and secure it with a hose clamp (also included). Run the drain hose to the nearest laundry tub or drain pipe. This can be ran up overhead or down along the floor. If running the drain line more than 20 ft overhead, it is recommended to increase the hose size to 3/4". NEVER MAKE A DIRECT CONNECTION INTO A WASTE DRAIN. A PHYSICAL AIR GAP OF AT LEAST 1.5" SHOULD BE USED TO AVOID BACTERIA AND WASTEWATER TRAVELLING BACK THROUGH THE DRAIN LINE INTO THE FILTER.
6. Using the Allen Key (included), place the unit in the bypass position. Slowly turn on the main water supply. At the nearest cold treated water tap nearby remove the faucet screen, open the faucet and let water run a few minutes or until the system is free of any air or foreign material resulting from the plumbing work.
7. Make sure there are no leaks in the plumbing system before proceeding. Close the water tap when water runs clean.
8. Proceed to start up instructions.

Note: *The unit is not ready for service until you complete the start-up instructions.*

Filter Installation

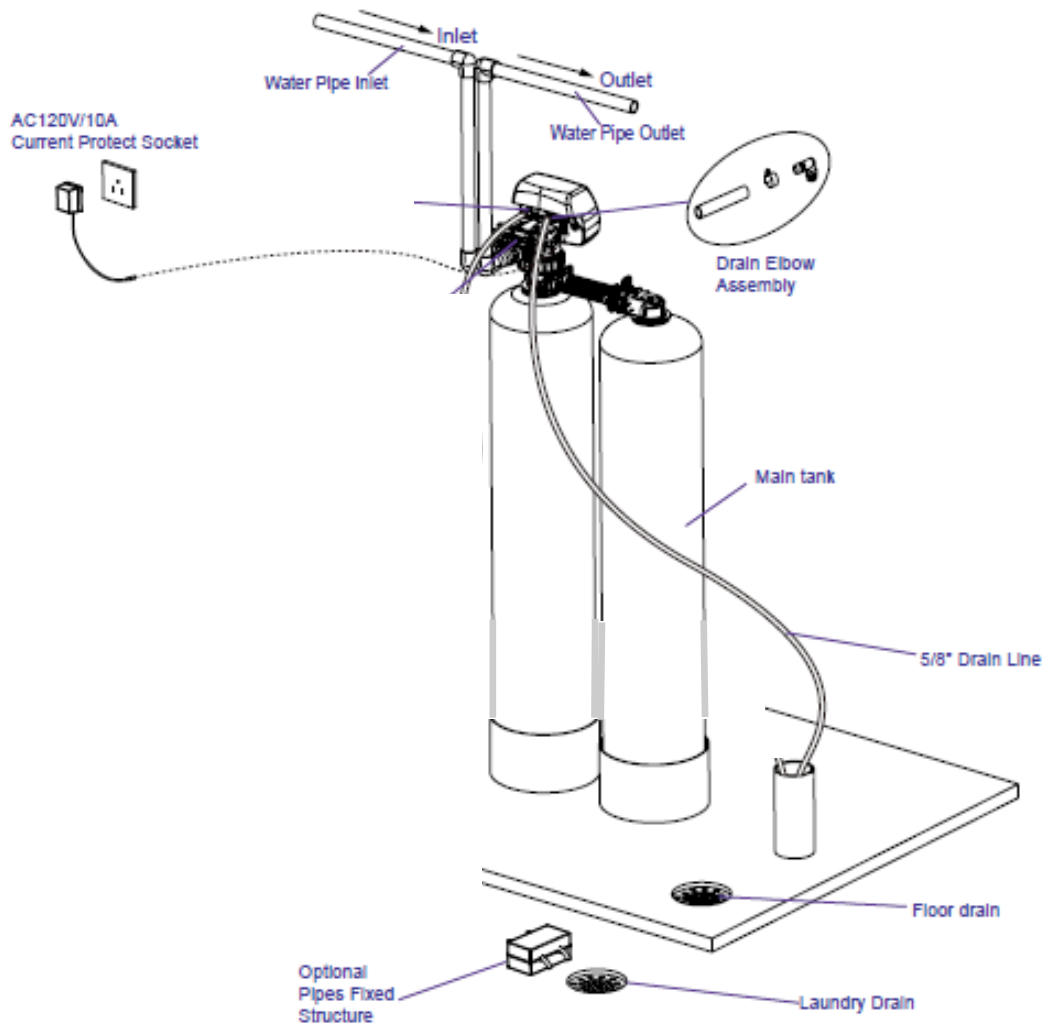

System Start-Up

Key Pad Configuration

SETTINGS	This function is to enter the basic set up information required at the time of installation.
MANUAL REGEN	This button has two functions. The first is to initiate an immediate or delayed manual regeneration. The second is while in programming mode, pressing this key allows the user to change the value of each setting.
DOWN / UP	Increase or decrease the value of the settings while in the programming mode.

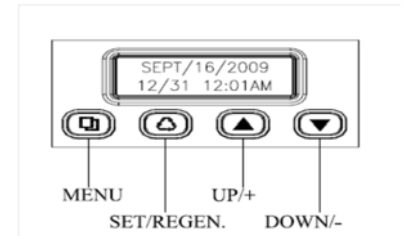

Start-up Instructions

1. Plug the valve into an approved power source.
2. When power is supplied to the control, the screen will display "WAITING PLEASE" while it finds the service position.
3. Start an Immediate Manual Regeneration. The valve will immediately start moving to the BACKWASH position.
4. Open the inlet on the bypass valve slightly and very slowly allow water to enter the unit. (If the water enters too quickly it will push the carbon up into the control valve and get plugged).
5. Once the unit has filled sufficiently that water is at least equal to the height of the top of the media shut down the water for 15 – 20 minutes for the carbon to soak. Unplug the power cable. After the carbon has soaked for the recommended time continue by plugging the power cable back in.
6. Turn the water back on slowly to backwash until water runs clear to drain.
7. Press any button to advance to the RINSE position. Check the drain line flow. Allow the water to run for 3-4 minutes or until the water is clear.
8. The valve will automatically advance to the SERVICE position after the RINSE cycle is complete. Open the outlet valve on the bypass, then open the nearest treated water faucet and allow the water to run until clear, close the tap and replace the faucet screen.
9. Program time, date, and number of days between regenerations into controller using Programming Instructions

Note : Carbon filters only:

Once the unit has filled sufficiently that water is at least equal to the height of the media shut down the water for 15 – 20 minutes for the carbon to soak. After the carbon has soaked for the recommended time continue with installation instructions.

Additional information for Non backwashing carbon filter.

After soaking, remove the aerator screen from the nearest faucet, run water at this faucet until all fines (black) is gone from the water.

Programming Instructions

Backwash Frequency

The table below can be used to help determine the frequency of regeneration for Multi-Media and Taste & Odour filters. Use this table as a guide since individual circumstances will require more or less frequent regenerations. This can be adjusted by the home owner to suite their individual needs with frequencies available from 1 – 99 days. To prevent bacterial build up in the media, activated carbon filters should not exceed 6 days between backwashes.

Sediment	Mild						Average						Extreme				
Taste Odor	Mild						Average						Extreme				
No. Of Persons	Days Between Back Wash (Regenerations)																
2	6	6	6	6	6	6	6	6	6	6	6	6	4	4	4	4	4
3	6	6	6	6	4	4	4	4	4	4	4	3	3	3	3	3	3
4	6	6	6	6	4	4	4	4	3	3	3	2	2	2	2	2	2
5	6	6	4	4	3	3	3	3	2	2	2	2	1	1	1	1	1
6	6	6	4	4	3	3	3	2	2	2	2	2	1	1	1	1	1
7	6	4	4	3	3	2	2	2	1	1	1	1	1	1	1	1	1
8	6	4	4	3	2	2	2	2	1	1	1	1	1	1	1	1	1
9	4	4	3	3	2	2	1	1	1	1	1	1	1	1	1	1	1
10	4	3	3	2	2	1	1	1	1	1	1	1	1	1	1	1	1

1. Press **SETTINGS** to enter programming. If the system has been inactive, you may have to hold and press **SETTINGS** to unlock the display screen. Press **UP** or **DOWN** to select which setting to modify.
2. To adjust a value, **MANUAL REGEN**. When the display flashes, the value may be changed. Press **UP** or **DOWN** to change the value. Press **MANUAL REGEN** again to accept the value.
3. Press **UP** or **DOWN** to advance to the next option.

Menu - Level 1

Press **SETTINGS** key

TIME
12:00AM

REG.TIME
12:00AM

DAYS
3

Page 1

Page 2

Example

STAR
PLUMBing

TEL (552)
764-1234

Manual Regeneration (Step / Cycle Valve)

If screen is locked, press and hold SETTINGS for 3 seconds to unlock. To initiate an immediate regeneration, press and hold the MANUAL REGEN key for 5 seconds. The valve will immediately start into manual regeneration.

To initiate a delayed regeneration, press the MANUAL REGEN key once to turn on and a regeneration will be queued at the next pre-set regeneration time (i.e. 2:00 a.m.).. To cancel, press the MANUAL REGEN key again.



About The System

Operation During A Power Failure

In the event of a power failure, the valve will keep track of the time and day for 48 hours. The programmed settings are stored in a non-volatile memory and will not be lost during a power failure. If power fails while the unit is in regeneration, the valve will finish regeneration from the point it is at once power is restored. If the valve misses a scheduled regeneration due to a power failure, it will queue a regeneration at the next regeneration time once power is restored.

Safety Float

The brine tank is equipped with a safety float which prevents your brine tank from overflowing as a result of a malfunction such as a power failure.

Main Display

When power is supplied to the control, the screen will display TIME OF DAY, GALLONS REMAINING, and DEALER NAME and PHONE NUMBER.

New Sounds

You may notice new sounds as your water softener operates. The regeneration cycle lasts up to 180 minutes. During this time, you may hear water running intermittently to the drain.

Regeneration Process

Periodically the filter will require a back wash to clean the trapped particles and unpack the filter bed to restore the system flow rates. The table below explains the regeneration steps.

Step	Name	Description
#1	Back Wash	Fresh water is introduced to the bottom of the tank flowing upwards expanding the filter media to rinse out any dirt or small particles to the drain and to uncompact the bed to restore full service flow rates.
#2	Rinse	Fresh water is introduced from the top of the tank flowing down through the filter bed rinsing any unfiltered water to the drain.

Maintenance

Maintenance of your new water filter requires very little time or effort but it is essential. Regular maintenance will ensure many years of efficient and trouble-free operation.

1. Periodically make sure your pump is performing satisfactorily to ensure sufficient water is available for backwashing the filter.
2. Periodically test your raw and filtered water to ensure conditions are still the same for your original settings and that the unit is working the way it is intended to. Water testing is often the best way to determine when the filter media will require replacement.
3. Periodically check that the drain line is clear and free from any obstructions.

Care of Your System

To retain the attractive appearance of your new water filter, clean occasionally with mild soap solution. Do not use abrasive cleaners, ammonia or solvents. Never subject your softener to freezing or to temperatures above 100°F.

Replacing the Media Bed

AC - Taste and Odor Filter - under normal operating conditions the effective life of the filter media is approximately one to three years, depending on the water quality, after which, taste and odor problems may return. When this happens, contact your dealer for a replacement media bed.

Installation & Replacement Filter Media Pak

Check to ensure all media parts are received.

The first step in replacing the media bed is to shut off the water supply to the filter. Then place the unit into the backwash position to release any pressure in the lines. At this point, you must disconnect the plumbing from the inlet and outlet. Then unscrew the control valve from the fiberglass tank. Once this has been done, remove the distributor tube. Then you can remove the filter media and two types of gravel from the tank. The quickest way to do this is by simply tipping the tank upside down into a large drum or pail. The tank must be rinsed out completely and have no media or gravel left in it at all.

Loading the Media Pak

Place the distributor tube back down the center of the tank. NOTE: the top of this tube should be plugged with a rag or cork to prevent media from entering. Pour the bag of coarse gravel into the tank, and then pour the bag of fine gravel into the tank.

It is important that the distributor tube is not moved or pulled out as it is not possible to put it down to the bottom of the tank once gravel or media are in the tank.

Finally pour the larger bag(s) of media into the tank in the following order:

Carbon Filters

1. Carbon

Once this is done, the rag or cork should be removed from the distributor tube. Clean off the top of the tank. Finally place the control valve on the tank and on to the distributor tube. Tighten the control valve on to the tank. Connect or reconnect the inlet and outlet and drain. The control valve should be in the backwash position. Slowly open the inlet valve water supply and slowly fill the filter tank until water appears at the open drain line. Return the control to the service position and shut the inlet off for approximately one hour to allow the media to soak in the water.

After one hour, turn inlet water on slowly and place the control into the backwash position and plug the unit's electrical cord into a constant power source. Let the unit continue through its regeneration cycle automatically. The regeneration is necessary so all media fines are backwashed down the drain to ensure clean filtered water.

Replacing Drain Line Flow Control (DLFC)

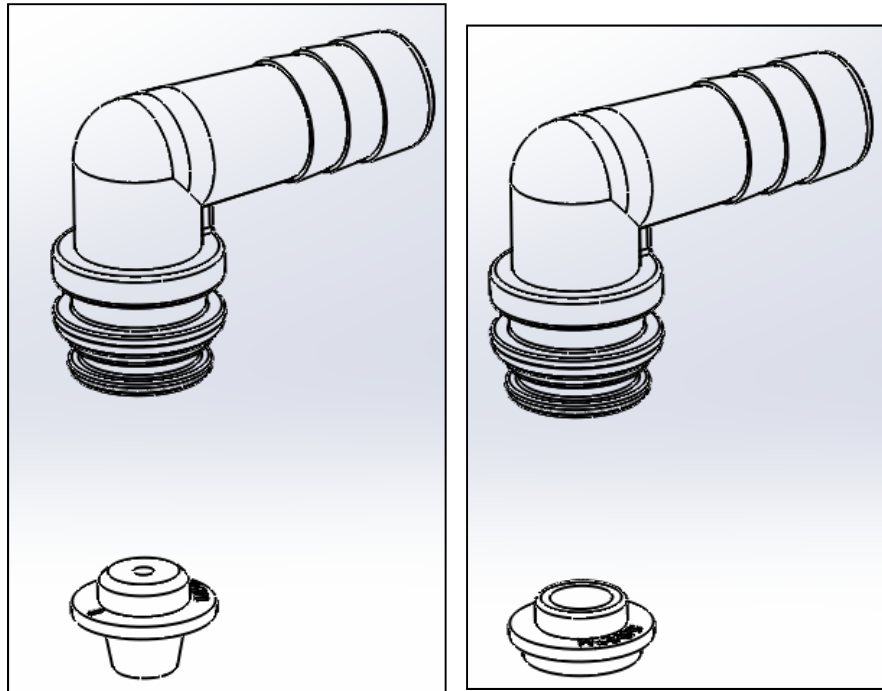

1. Remove the red clip that secures the drain line elbow.
2. Remove the BLFC washer from the elbow fitting.
3. Reassemble using the reverse procedure.

Main Repair Parts

REPLACEMENT PARTS - FILTER			
Replacement Part Number	Part Description	DWG #	Quantity
60010052	POWER TRANSFORMER 120V-12V	A	1
60010002	BYPASS / METER	B	1
10010063	485 UP DOWN FLOW FILTER VALVE	C	1
60010048	TOP CONE	D	1
25020041	844 TANK (75)	E	1
25020042	948 TANK (100)	E	1
25020043	1054 TANK (150)	E	1
25010058	1252 TANK (200)	E	1
25030007	1465 TANK (300)	E	1
50010005	DISTRIBUTOR 1X54	F	1

Main Repair Parts - Connectors

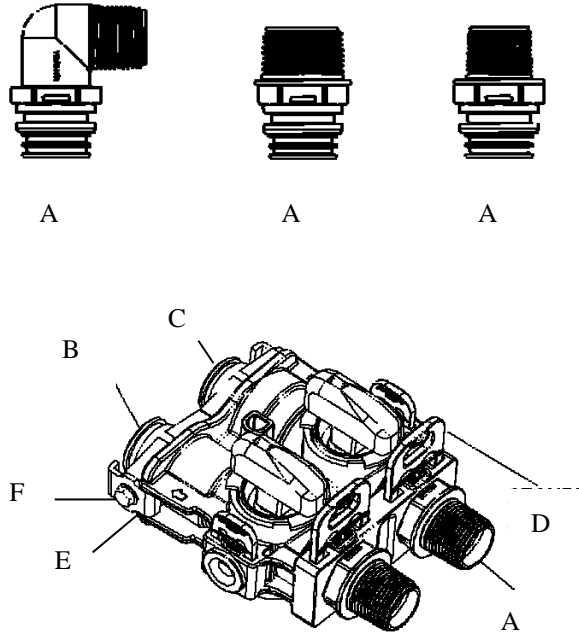

REPLACEMENT PARTS - CONNECTORS			
Replacement Part Number	Part Description	DWG #	Quantity
60010020	3/4" NPT ELBOW	A	2
60010019	1" NPT STRAIGHT	A	2
60010023	3/4" NPT STRAIGHT	A	2
60010079	VALVE COUPLING INLET	B	1
60010101	VALVE COUPLING OUTLET (METER SIDE)	C	1
60010025	PLASTIC SECURE CLIP	D	2
60010046	BYPASS SS CLIP	E	2
60010047	BYPASS SS SCREW	F	2

Control Valve Exploded View

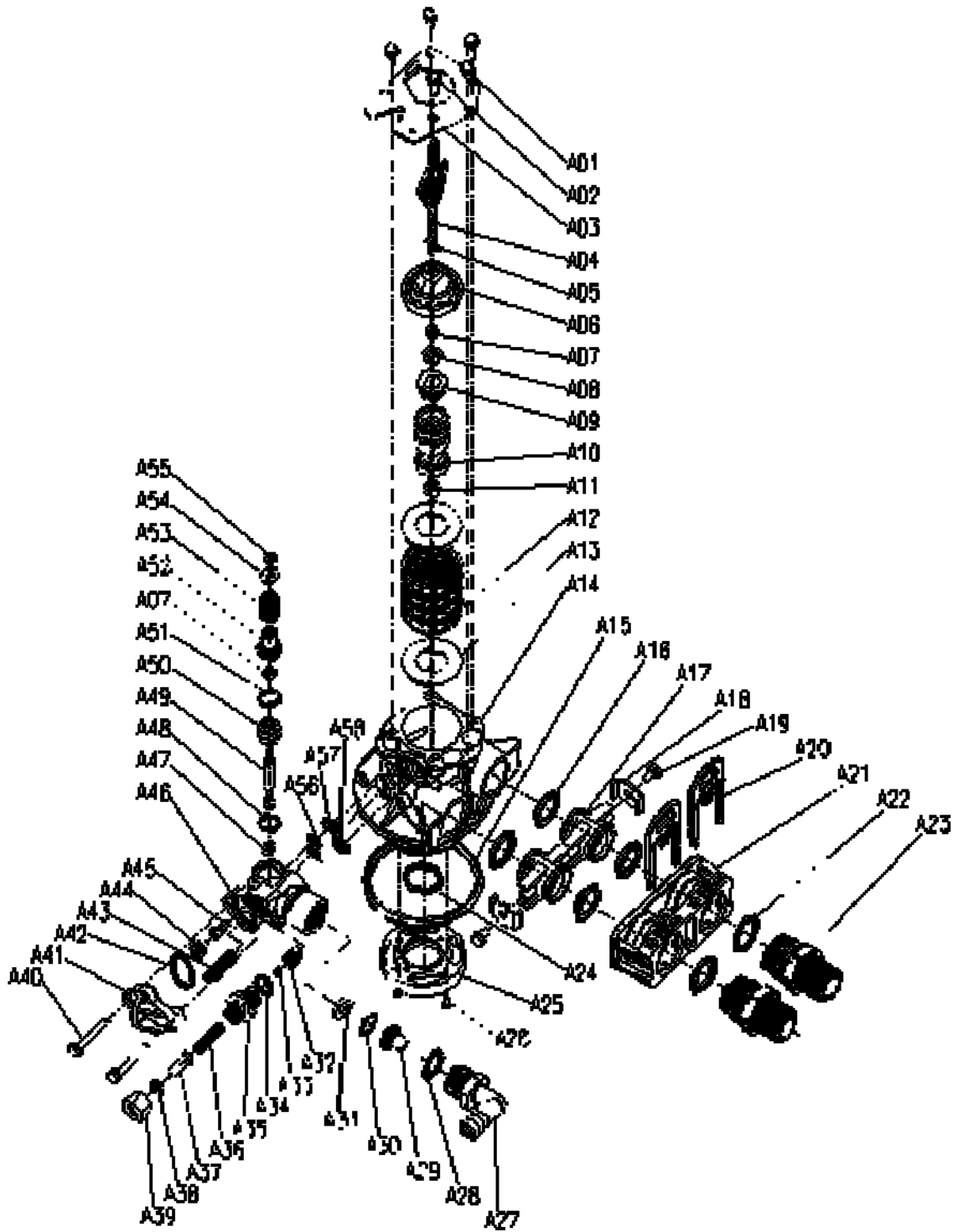

Control Valve Parts List

Item No.	Part No.	Part Description	Quantity
A01	05056087	Screw-M5×12(Hexagon)	3
A02	05056088	Screw-M5×16(Hexagon with Washer)	2
A03	05056047	End Plug Retainer	1
A04	05010081	Bnt65 Piston Rod	1
A05	05056097	Piston Pin	1
A06	05056023	End Plug	1
A07	05056070	Quad Ring	2
A08	05056024	End Plug Washer	1
A09	05056022	Piston Retainer	1
A10	05056181	Piston (Electrical)	1
A11	05056104	Muffler	1
A12	05056021	Spacer	4
A13	05056073	Seal	5
A14	05056019	Bnt65 Valve Body	1
A15	05056063	O-ring- ϕ 78.74×5.33	1
A16	05056129	O-ring- ϕ 23×3	4
A17	05056025	Adaptor Coupling	2
A18	05056044	Adaptor Clip	2
A19	05056090	Screw-ST4.2×13(Hexagon with Washer)	2
A20	21709003	Secure Clip	2
A21	05056140	Valve Connector	1
A22	05056065	O-ring- ϕ 23.6×2.65	2
A23	21319006	Screw Adaptor	2
A24	26010103	O-ring- ϕ 25×3.55	1
A25	07060007	Valve Bottom Connector	1
A26	13000426	Screw-ST2.9×13(Large Wafer)	2
A27	05056038	Drain Fitting	1
A28	26010003	O-Ring- ϕ 18×2.65	1
A29	05056036	DLFC Button Retainer	1
A30	05056079	O-Ring- ϕ 15×0.8	1
A31	05056143	DLFC-2#	1
A32	05056035	BLFC Button Retainer	1
A33	05056191	BLFC-2#	1
A34	05056138	O-Ring- ϕ 14×1.8	1
A35	05056100B	BLFC Fitting	1
A36	05056106	Brine Line Screen	1
A37	05056107	BLFC Tube Insert	1
A38	05056033	BLFC Ferrule	1
A39	05056108	BLFC Fitting Nut	1
A40	05056086	Screw-M5×30(Hexagon with Washer)	2
A41	05056029	Injector Cover	1

Power Head Exploded View

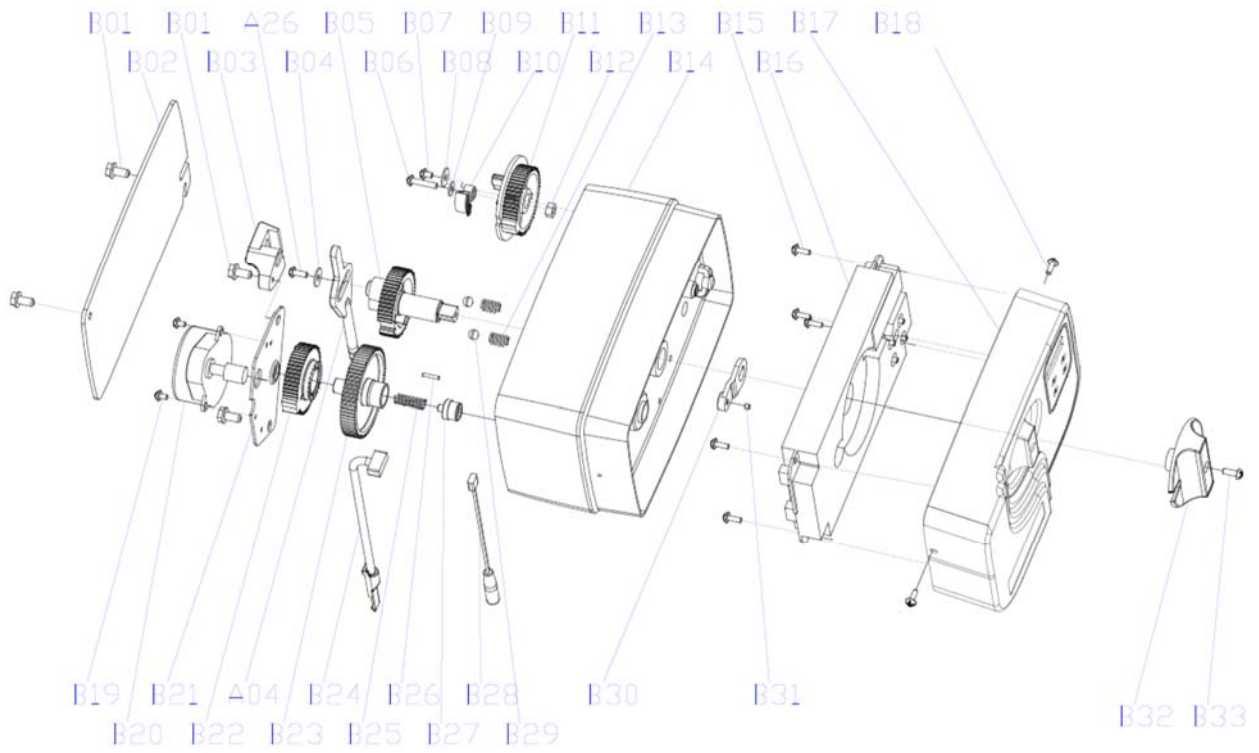

Power Head Parts List

Item No.	Part No.	Part Description	Quantity
B01	5056136	Screw-ST3.5×13(Hexagon with Washer)	4
B02	5056014	Bnt65 Back Cover	1
B03	5010045	Piston Stem Holder	1
A26	13000426	Screw-ST2.9×13(Large Wafer)	1
B04	5056139	Washer-3x13	1
B05	5056005	Main Gear	1
B06	5056083	Screw-M4x14	1
B07	5056166	Screw-ST4.2×12(Large Wafer)	1
B08	5056141	Washer-4x12	1
B09	13111004	Washer-4x9	1
B10	5056016	Refill Regulator	1
B11	5056015	Brine Gear	1
B12	5056089	Nut-M4	1
B13	5056095	Spring Detent	2
B14	5056001	Bnt65 Housing	1
B15	5010037	Screw-ST2.9×10	5
B16	5056504	Bnt165 Pcb	1
B17	5056500	Bnt165 Front Cover	1
	5056505	Bnt165 Operation Label	1
	5056506	Bnt165 Regen. Label	1
B18	5056509	Screw-ST2.9×10(CSK)	2
B19	5056082	Screw-M3×5	2
B20	5056510	Motor-12v/2rpm	1
	11700005	Wire Connector	2
B21	5056045	Motor Mounting Plate	1
B22	5056501	Bnt165 Drive Gear	1
A04	5010081	Bnt65 Piston Rod	1
B23	5056002	Idler Gear	1
B24	5010031	Meter Assembly	1
	5010046	Meter Strain Relief	1
B25	5056094	Spring Idler	1
B26	5056098	Motor Pin	1
B27	5056502	Spring Retainer	1
B28	5056507	Bnt165 Power Cable	1
	5056013	Bnt65 Power Strain Relief	1
B29	5056092	Ball-1/4inch	2
B30	5056503	Magnet Holder	1
B31	5010023	Magnet-φ3×2.7	1
B32	5056008	Bnt65 Knob	1
	5056111	Bnt65 Knob Label	1
B33	5056084	Screw-ST3.5x13	1

Trouble Shooting

Issue	Possible Cause	Possible Solution
A. Unit fails to initiate a regeneration cycle.	1. No power supply.	Check electrical service, fuse, etc.
	2. Defective circuit board.	Replace faulty parts.
	3. Power failure.	Reset time of day.
B. FILTER BLEEDS TASTE AND ODOR OR SEDIMENT	1. By-pass valve open.	Close by-pass valve.
	2. Electrical service to unit has been interrupted	Assure permanent electrical service (check fuse, plug or switch)
	3. Defective or stripped media bed	Replace media
	4. Quality of water has worsened	Have water sample analyzed to determine any change
	5. Filter capacity too small	Replace with larger unit or add another filter
	6. Filter not backwashing enough	Be sure control is not clogged or drain line restricted. Be sure water pressure has not dropped and that pump has sufficient capacity.
	7. Leak between valve and central tube.	Check if central tube is cracked or o-ring is damaged. Replace faulty parts.
	8. Internal valve leak.	Replace valve seals, spacer, and piston assembly.
C. Low water pressure.	1. Iron or scale build up in line feeding unit.	Clean pipes.
	2. Iron build up inside valve or tank.	Clean control and add resin cleaner to clean bed. Increase regeneration frequency.
	3. Inlet of control plugged due to foreign material.	Remove piston and clean control valve.
D. Filter media in drain line.	1. Air in water system.	Check well system for proper air eliminator control.
	2. Incorrect drain line flow control (DLFC) button.	Check for proper flow rate.
E. Valve continuously cycles.	1. Defective position sensor PCB.	Replace faulty parts.
F. Flow to drain continuously.	1. Valve settings incorrect.	Check valve settings.
	2. Foreign material in control valve.	Clean control.
	3. Internal leak.	Replace seals, spacers, and piston assembly.

Blank page

Warranty

Canature WaterGroup guarantees that your new water conditioner is built of quality material and workmanship. When properly installed and maintained, it will give years of trouble free service.

Five Year Limited Warranty

Canature WaterGroup will replace the salt tank or cabinet tank, the ion exchange resin, valve parts and the fibreglass mineral tank which has a 10 year warranty, provided the failure is due to a defect in material or workmanship and not the result of damage from any of the conditions described in the general conditions of this warranty.

General Conditions

Damage to any part of this water conditioner as a result of misuse, misapplication, neglect, alteration, accident, installation or operation contrary to our printed instructions, damage to ion exchange resin and seals caused by chlorine / chloramines in the water supply, or damage caused by any force of nature is not covered in this warranty. Filters are commonly exposed to high levels of iron, manganese, sulphur, and sediment. Damage to pistons, seals, and or spacers within the control valve are not covered in this warranty due to harsh environment. We will repair or replace defective parts if our warranty department determines it to be defective under the terms of this warranty. Canature WaterGroup assumes no responsibility for consequential damage, labour or expense incurred as a result of a defect or failure.