165 Series

Softener Operation Manual



WQA Tested and Certified according to NSF/ANSI 44 for effective reduction of hardness (calcium and magnesium) as verified and substantiated by test data.

Tested and Certified by the Water Quality Association to CSA B483.1.

Note:

1. Read all instructions carefully before operation.
2. Avoid pinched o-rings during installation by applying (provided with install kit) NSF certified lubricant to all seals.
3. This system is not intended for treating water that is microbiologically unsafe or of unknown quality without adequate disinfection before or after the system.

Canadian Head Office
655 Park St.
Regina, SK S4N 5N1

Eastern Sales & Distribution
20 Steckle Place, Unit 21
Kitchener ON N2E 2C3

TABLE OF CONTENTS

Water Softener Gallon Setting Chart..... 2

System Specifications..... 3

Introduction 4

Programming 5

General System Installation 7

Start-up Instructions 8

System Configuration..... 9

Maintenance..... 10

Power Head Valve Exploded View..... 12

Power Head Parts List 13

Control Valve Exploded View 14

Control Valve Parts List 15

Trouble Shooting 16

Guarantee..... 17

Efficiency Statement

This product is efficiency rated according to NSF/ANSI 44. The stated efficiencies are valid only at the specified salt dosages and maximum service flow rate.

Product Data Sheet

Model Number	165-75C	165-100C	165-75	165-100	165-150	165-200	165-300
Qty High Capacity Resin	0.75 ft ³	1.0 ft ³	0.75 ft ³	1.0 ft ³	1.5 ft ³	2.0 ft ³	3.0 ft ³
Rated Service Flow (gpm)	7.5	12.1	7.5	11.0	11.2	12.4	12.9
Pressure Drop at Rated Service Flow (psi)	7.0	15.0	9.0	15.0	15.0	15.0	15.0
Rated Softening Capacity (grains)	9,609 @ 2.25lbs	13,269 @ 3lbs	10,222 @3lbs	13,269 @ 3lbs	20,443 @ 4.5lbs	27,258 @ 6lbs	40,887 @ 9lbs
Efficiency (grains/lb salt)	4,271	4,543	4,543	4,543	4,543	4,543	4,543
Max. Flow Rate to Drain (gpm)	2.0	2.4	1.5	2.0	2.4	3.5	5.0
Working Pressure	Min. 20 - Max. 125 psi						
Operating Temperature	Min 39 - Max. 100 degrees Fahrenheit						

These softeners conform to NSF/ANSI 44 for the specific performance claims as verified and substantiated by test data. These models are efficiency rated. The efficiency rating is valid only at the stated salt dose and maximum service flow rate. They have a demand initiated regeneration (D.I.R.) feature that complies with specific performance specifications intended to minimize the amount of regenerant brine and water used in their operation. These softeners have a rated softener efficiency of not less than 3350 grains of total hardness exchange per pound of salt (based on sodium chloride) and shall not deliver more salt than their listed ratings. The rated salt efficiency is measured by laboratory tests described in NSF/ANSI Standard 44. These tests represent the maximum possible efficiency that the systems can achieve. Operational efficiency is the actual efficiency after the system has been installed. It is typically less than the efficiency due to individual application factors including water hardness, water usage, and other contaminants that reduce the softener’s capacity. These systems are not intended for use with water that is microbiologically unsafe or of unknown quality without adequate disinfection before or after the system. For best results, use plain, white block salt. Refer to Installation/operation manual and warranty for further details on installation, parts and service, maintenance and further restrictions or limitations to the use of the product.



WQA Tested and Certified according to NSF/ANSI 44 for effective reduction of hardness (calcium and magnesium) as verified and substantiated by test data.

Tested and Certified by the Water Quality Association to CSA B483.1.

Water Softener Gallon Setting Chart

Water Softener Gallon Setting Chart

Instructions: First select the chart for your model of water softener, then simply line up the number of people living in the home with the hardness of the water and select the appropriate gallon setting for your model.

at 6lbs salt/CF		Total Hardness in Grains per US Gallon														
.75 CF		10	15	20	25	30	35	40	45	50				50		
Number of people living in the home	1	1575	1025	750	585	475	396	338	292	255				255		
	2	1500	950	675	510	400	321	263	217							
	3	1425	875	600	435	325										
	4	1350	800	525												
	5	1275	725													
	6	1200														
	7	1125														
	8	1050														
Softener could be undersized if # of people and hardness line up in this shaded area. Consideration may be given to a larger size unit to meet your needs.																
1.0 CF		Total Hardness in Grains per US Gallon														
		10	15	20	25	30	35	40	45	50	55	60	65	70		
Number of people living in the home	1	2125	1392	1025	805	658	554	475	414	365	292	250	217	263		
	2	2050	1317	950	730	583	479	400	339	290	250	217				
	3	1975	1242	875	655	508	404	325								
	4	1900	1167	800	580	433										
	5	1825	1092	725												
	6	1750	1017													
	7	1675	942													
	8	1600	867													
	9	1525														
	10	1450														
Softener could be undersized if # of people and hardness line up in this shaded area. Consideration may be given to a larger size unit to meet your needs.																
1.5 CF		Total Hardness in Grains per US Gallon														
		10	15	20	25	30	35	40	45	50	55	60	65	70	75	
Number of people living in the home	1	3225	2125	1575	1245	1025	868	750	658	585	475	433	396	365		
	2	3150	2050	1500	1170	950	793	675	583	510	450	400	358	321		
	3	3075	1975	1425	1095	875	718	600	508	435	375	325				
	4	3000	1900	1350	1020	800	643	525	433							
	5	2925	1825	1275	945	725	568									
	6	2850	1750	1200	870	650										
	7	2775	1675	1125	795											
	8	2700	1600	1050												
	9	2625	1525	975												
	10	2550	1450													
Softener could be undersized if # of people and hardness line up in this shaded area. Consideration may be given to a larger size unit to meet your needs.																
2.0 CF		Total Hardness in Grains per US Gallon														
		10	15	20	25	30	35	40	45	50	55	60	65	70	75	
Number of people living in the home	1	4325	2858	2125	1685	1392	1182	1025	903	805	725	658	602	554	512	
	2	4250	2783	2050	1610	1317	1107	950	828	730	650	583	527	479	437	
	3	4175	2708	1975	1535	1242	1032	875	753	655	575	508	452	404	362	
	4	4100	2633	1900	1460	1167	957	800	678	580	500	433				
	5	4025	2558	1825	1385	1092	882	725	603							
	6	3950	2483	1750	1310	1017	807									
	7	3875	2408	1675	1235	942										
	8	3800	2333	1600	1160	867										
	9	3725	2258	1525	1085											
	10	3650	2183	1450												
Softener could be undersized if # of people and hardness line up in this shaded area. Consideration may be given to a larger size unit to meet your needs.																
3.0 CF		Total Hardness in Grains per US Gallon														
		10	15	20	25	30	35	40	45	50	55	60	65	70	75	
Number of people living in the home	1	6525	4325	3225	2565	2125	1811	1575	1392	1245	1125	1025	940	868	805	
	2	6450	4250	3150	2490	2050	1736	1500	1317	1170	1050	950	865	793	730	
	3	6375	4175	3075	2415	1975	1661	1425	1242	1095	975	875	790	718	655	
	4	6300	4100	3000	2340	1900	1586	1350	1167	1020	900	800				
	5	6225	4025	2925	2265	1825	1511	1275	1092							
	6	6150	3950	2850	2190	1750	1436	1200								
	7	6075	3875	2775	2115	1675	1361	1125								
	8	6000	3800	2700	2040	1600										
	9	5925	3725	2625	1965											
	10	5850	3650	2550												
Softener could be undersized if # of people and hardness line up in this shaded area. Consideration may be given to a larger size unit to meet your needs.																

Figure 1. Gallon Setting Chart

System Specifications

Item #	Model	Capacity Grains			Flow Rate		Mineral Tank Size	Resin Cu. Ft.	Brine Tank / Cabinet Size Inches	Salt Cap Lbs	Shipping Weight Lbs
		@ 10 lbs/cu ft	@ 6 lbs/cu ft (Factory Setting)	@ 3 lbs/cu ft	Service USGPM	Backwash USGPM					
15010020	CAN165-75	19,875	16,500	10,500	8.0	1.5	8 x 44	0.75	15.0 x 15.0 x 34.7	230	93
15010021	CAN165-100	26,500	22,000	14,000	10.0	2.0	9 x 48	1.00	15.0 x 15.0 x 34.7	230	110
15010022	CAN165-150	39,750	33,000	21,000	12.0	2.4	10 x 54	1.50	15.0 x 15.0 x 34.7	230	141
15010023	CAN165-200	53,000	44,000	28,000	15.0	3.0	12 x 52	2.00	20.3 x 37.4	385	158
15010025	CAN165-250	66,250	55,000	35,000	15.0	4.0	13 x 54	2.50	20.3 x 37.4	385	198
15010026	CAN165-300	79,500	66,000	42,000	15.0	5.0	14 x 65	3.00	23.0 x 40.5	550	244
15010027	CAN165-75C	19,875	16,500	10,500	8.0	2.0	9 x 35	0.75	13.8 x 23.6 x 43.3	225	93
15010028	CAN165-100C	26,500	22,000	14,000	10.0	2.4	10 x 35	1.00	13.8 x 23.6 x 43.3	225	110

Figure 2. Specifications

- C indicates cabinet Models
- Water Temperature = Min 39°F / Max 110°F
- Operating Pressure = Min 20 PSI / Max 120 PSI
- Voltage = 110 volts standard
- Units contain 8% Super Capacity Ion Exchange Resin
- At the stated service flow rates, the pressure drop through these devices will not exceed 15 psig.
- Changing salt settings from factory setting may require changing injector sizes to achieve stated capacities.
- The manufacturer reserves the right to make product improvements which may deviate from the specifications and descriptions stated herein, without obligation to change previously manufactured products or to note the change.
- The above capacity and flow rate specifications have not been validated by WQA.

How Your Water Conditioner Works

The principle behind water softening is simple chemistry. A water softener contains resin beads which hold electrically charged ions. When hard water passes through the softener, calcium and magnesium ions are attracted to the charged resin beads. It's the resulting removal of calcium and magnesium ions that produces soft water.

This system is controlled with simple, user-friendly electronics displayed on a LCD screen. The main page displays the current time and the remaining gallons in meter mode or the remaining days in calendar clock mode.

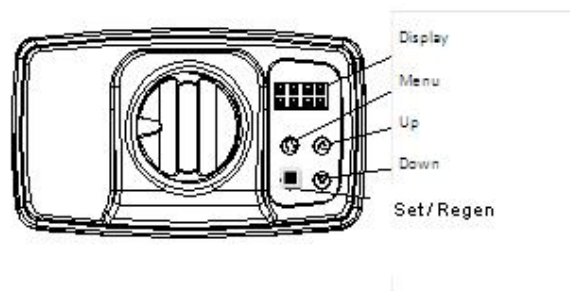

Figure 3. Valve Display

System Initialization

When power is supplied to the control, the screen will display TIME OF DAY AND DEFAULT GALLON SETTING. If the valve is not in service it will read "CANATURE" while the valve returns to the service position.

Programming

There are 3 levels to the valve program. Master options and Factory options are typically adjusted at the factory. These options link the PCB function with the type of control valve and should not be tampered with. Advanced options are used to configure the unit when the valve is assembled to the tank so that it can function as the proper size and intended system operation. Settings are the final options chosen when the unit is installed to a specific location.

Programming Levels

PROGRAM LEVEL	USER ACCESS
MASTER (III)	These settings are programmed by the factory. The settings are important for the operation of the valve that should only be changed by a qualified person.
FACTORY (II)	These settings are programmed by the factory and should be adjusted when the valve is assembled into a unit or system. It contains important settings so the valve will operate properly for the type of system it is intended for. The settings should only be changed by qualified person.
USER SETTINGS(I)	These settings are programmed when the unit is installed. The settings should only be adjusted by a qualified person.

Main Display Options

The main display page according to the regeneration mode setting. The display will alternate between the time of day, remaining gallons, and remaining days.

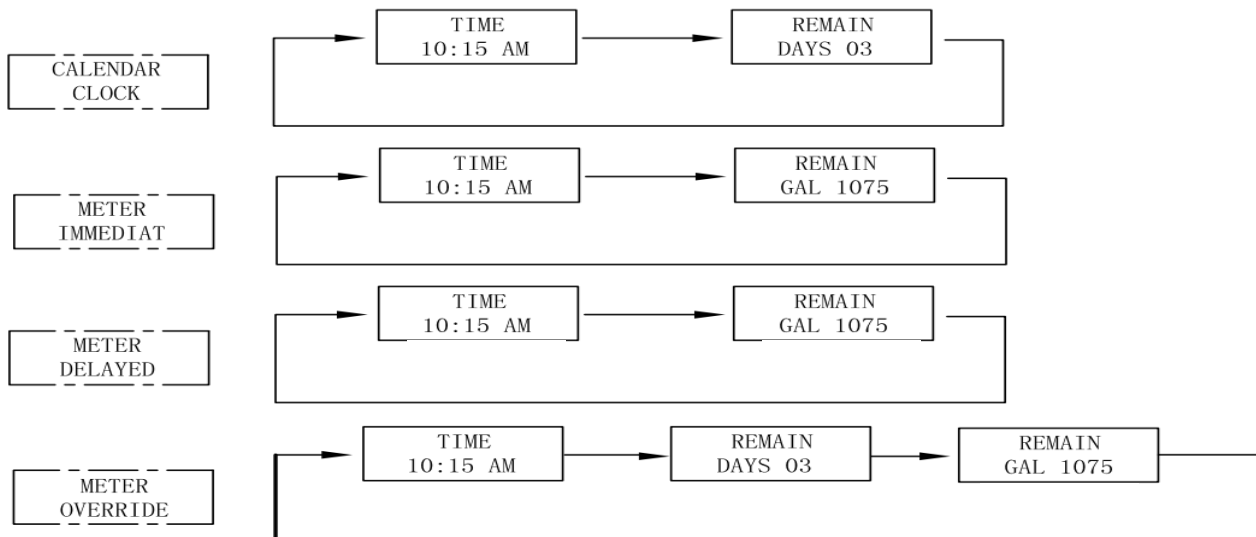

Manual Regeneration

IMMEDIATE REGENERATION

To start an immediate regeneration turn the knob clockwise from the service position (9:00) to the 10:00 position. Within a few seconds the an immediate regeneration will begin. Using the knob you can manually advance to the next position. Pressing any button will also advance to the next position.

There is no DELAYED REGENERATION function.

Master Options (Level III)

Press SETTINGS + UP + DOWN. Hold until you hear a beep (3 seconds).

Press UP or DOWN to advance each page.

Press SETTINGS to initiate a change.

Press UP or DOWN to change value.

Press SETTINGS to accept value. Press UP or DOWN to advance to next page.

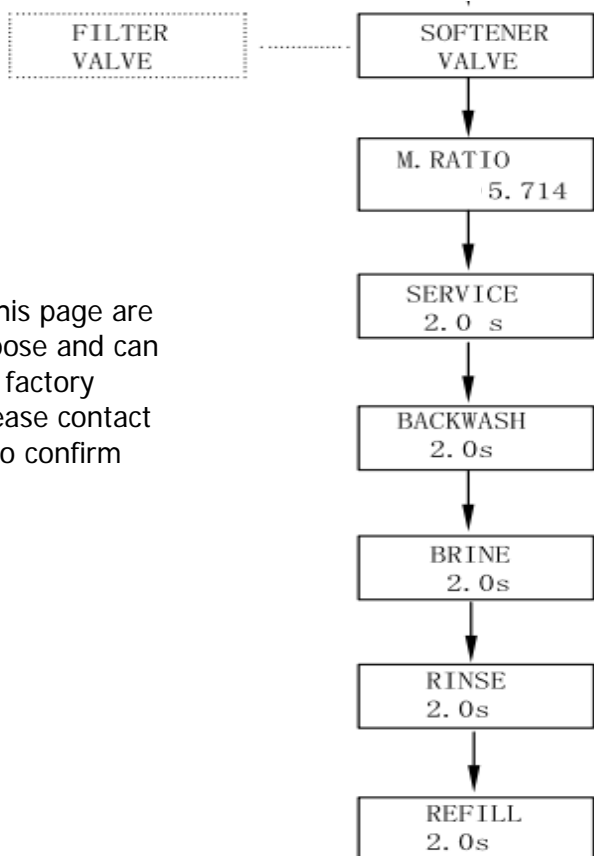

CAUTION:

The values in this page are for illustration purpose and can be changed by the factory without notice. Please contact Customer Service to confirm

VALVE TYPE

The valve must be designated as either SOFTENER or FILTER. This change will determine what options are available in the Factory Settings.

METER RATIO

The meter ratio calibrates the pulse from the flow meter into gallons. This value is factory set and should not be changed.

DELAY SETTINGS

The delay settings are used to precisely stop the motor / piston in the correct position. This value is factory set and should not be changed.

Factory Options (Level II)

Press UP + DOWN. Hold until you hear a beep (3 seconds).
Press UP or DOWN to change value.
Press SETTINGS to accept change and advance to next page.

Softener Mode

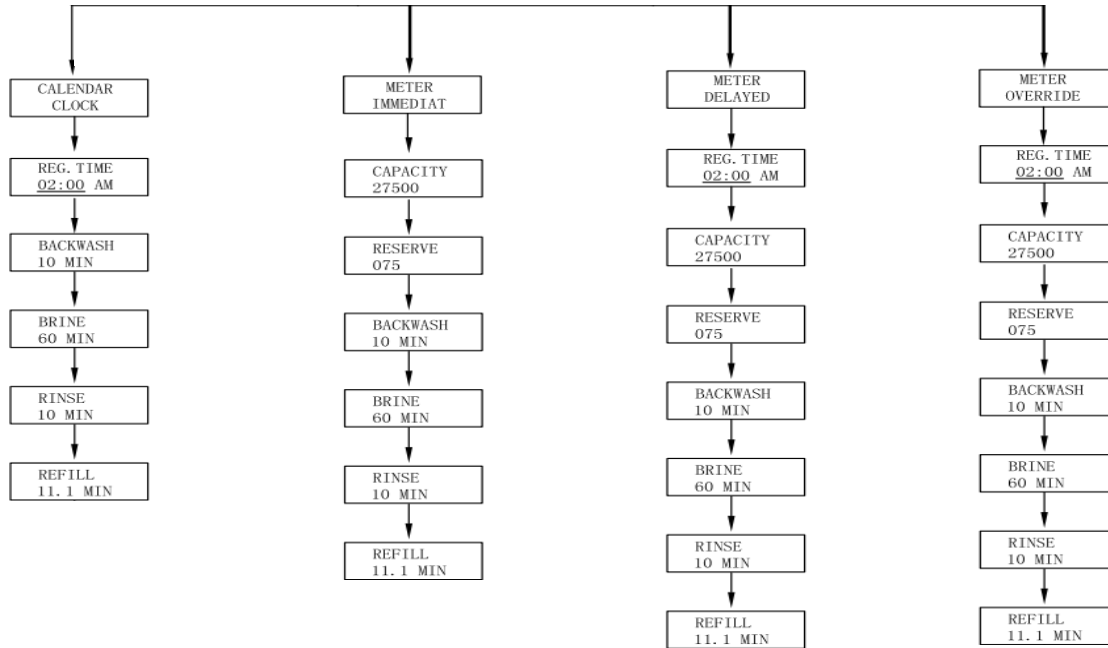

CAUTION:

The values in this page are for illustration purpose and can be changed by the factory without notice. Please contact Customer Service to confirm

Filter Mode

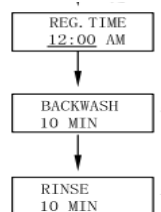

User Settings (Level I)

Press SETTINGS.
Press UP or DOWN to change value.
Press SELECT to accept change and advance to next page.

Softener Mode

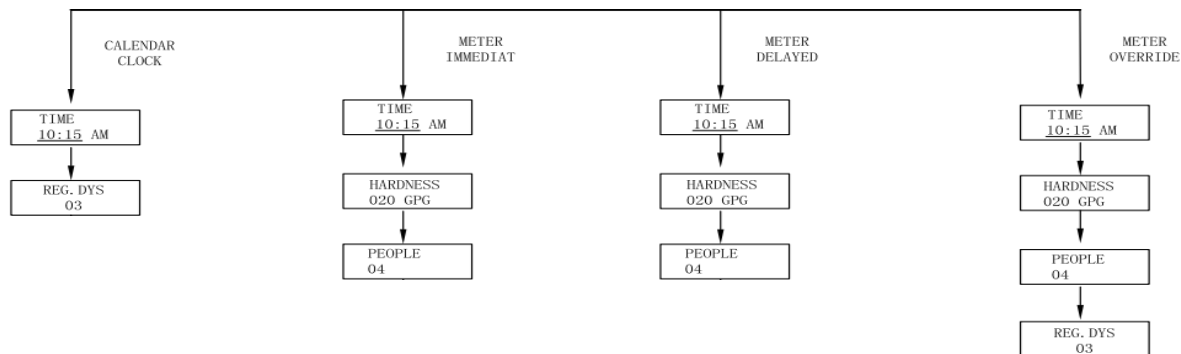

CAUTION:
The values in this page are for illustration purpose and can be changed by the factory without notice. Please contact Customer Service to confirm

Filter Mode

Press SETTINGS.
Press UP or DOWN to change value.
Press SELECT to accept change and advance to next page.

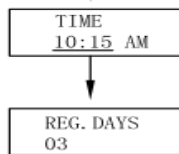

General Installation

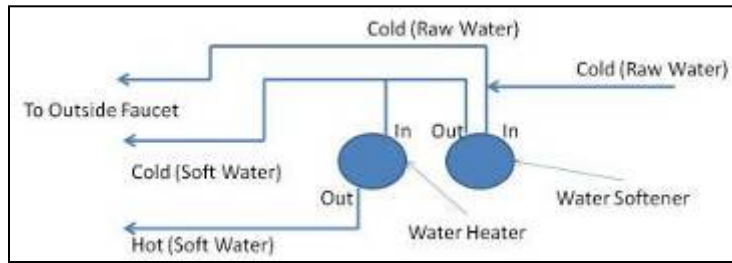
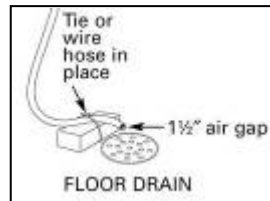

Figure 6. Piping Diagram

- 1) Locate the softener tank and brine tank close to a drain where the system will be installed. The surface should be clean and level.
- 2) Perform all plumbing according to local plumbing codes.
 - a) Use a 1/2" minimum pipe or tubing size for the drain line
 - b) Use a 3/4" pipe or tubing for backwash flow rates that exceed 7 gpm or length that exceeds 20ft (6 m)
 - c) **ON COPPER PLUMBING SYSTEMS BE SURE TO INSTALL A GROUNDING WIRE BETWEEN THE INLET AND OUTLET PIPING TO MAINTAIN GROUNDING.**
- 3) Any solder joints near the valve must be done before connecting any piping to the valve. Always leave at least 6" (152 mm) between the valve and joints when soldering pipes that are connected to the valve. Failure to do this could cause damage to the valve.
- 4) If the valve is not installed on the tank, cut the 1" central pipe flush with top of each tank. Lubricate the large o-ring on the valve that seals against the tank. Screw the valve on to the tank. Be careful to not cross thread the valve into the tank. Only use silicone lubricant.
- 5) Connect the drain hose to the valve and secure it with a hose clamp. Run the drain hose to the nearest laundry tub or drain pipe. This can be ran up overhead or down along the floor. If running the drain line more than 20 ft overhead, it is recommended to increase the hose size to 3/4". NEVER MAKE A DIRECT CONNECTION INTO A WASTE DRAIN. A PHYSICAL AIR GAP OF AT LEAST 1.5" SHOULD BE USED TO AVOID BACTERIA AND WASTEWATER TRAVELLING BACK THROUGH THE DRAIN LINE INTO THE SOFTENER.



- 6) Connect the brine line from the valve to the air check / safety elbow as per figure 7. Double check to make sure all connections are assembled correctly and the brass and plastic nuts are tight and secure to prevent leaks.
- 7) Add water until there is approximately 1" (25 mm) of water above the grid plate. If the tank does not have a grid, add water until it is above the air check in the brine tank. Do not add salt to the brine tank at this time.
- 8) Place the unit in the bypass position.
- 9) Slowly turn on the main water supply.
- 10) At the nearest cold treated water tap nearby remove the faucet screen, open the faucet and let water run a few minutes or until the system is free of any air or foreign material resulting from the plumbing work. Close the water tap when water runs clean, then proceed to start up instructions.

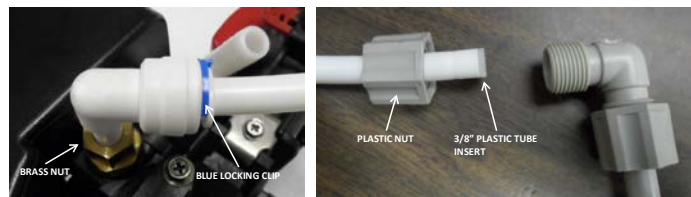

Figure 7. Brine Line Connections View

Start-Up Instructions

1. Plug the valve into an approved power source.
2. When power is supplied to the control, the screen will display TIME OF DAY and DEFAULT GALLON SETTING. If the valve is not in service it will read "CANATURE" while the valve returns to the service position.
3. If the system has been inactive, you may have to hold and press '⏏' until you hear a beep to unlock the display screen. Press "■" to initiate a manual regeneration and advance the valve to the Backwash position. Open the inlet on the bypass valve slowly and allow water to enter the unit. Allow all air to escape from the unit before turning the water on fully then allow water to run to drain for 3-4 minutes or until all media fines are washed out of the softener or filter.
4. Press the "■" to advance to the BRINE position. Check the water level in the brine tank to insure the valve is drawing brine properly.
5. Press the "■" to advance to the RINSE position. Check the drain line flow. Allow the water to run for 3-4 minutes or until the water is clear.
6. Press the "■" to advance to the REFILL position. Check that the valve is filling water into the brine tank. Allow the valve to refill for the correct amount of time as displayed on the screen to insure a proper brine solution for the next regeneration.
7. Press the "■" to advance to the SERVICE position. Open the outlet valve to the bypass, then open the nearest treated water faucet and allow the water to run until clear, close the tap and replace the faucet screen.
8. Put salt into the brine tank.

Control Operation During A Power Failure

In the event of power failure, the valve will keep track of the time and day for 48 hours. The programmed settings are stored in a non-volatile memory and will not be lost during a power failure. If power fails while the unit is in regeneration, the valve will return to the service position once power is restored. If the valve misses a scheduled regeneration due to a power failure, it will queue a regeneration at the next regeneration time once power is restored.

System Configuration

RESIN VOLUME	SYSTEM CAPACITY (GRAINS)				CYCLE TIME (MINUTES)			REFILL TIME (MINUTES) @ 0.70 GPM BLFC			
	@ 15 lbs/cu ft	@ 10 lbs/cu ft	@ 6 lbs/cu ft (Factory Setting)	@ 3 lbs/cu ft	BACKWASH	BRINE/RINSE	RINSE	@ 15 lbs/cu ft	@ 10 lbs/cu ft	@ 6 lbs/cu ft (Factory Setting)	@ 3 lbs/cu ft
0.75	22,500	19,875	16,500	10,500	10.0	60.0	10.0	6.0	4.0	2.0	1.1
1.00	30,000	26,500	22,000	14,000	10.0	60.0	10.0	7.0	5.0	3.0	1.5
1.50	45,000	39,750	33,000	21,000	10.0	60.0	10.0	11.0	7.0	5.0	2.0
2.00	60,000	53,000	44,000	28,000	10.0	60.0	10.0	14.0	10.0	6.0	3.0
3.00	90,000	79,500	66,000	42,000	10.0	60.0	10.0	21.0	14.0	9.0	4.3

Figure 8. Valve Cycle Settings

Injector and Drain Line Flow Control

Suggested Softener Valve Configuration			
Tank Size (Diameter)	Injector Set	Brine Line Flow Control (BLFC)	Drain Line Flow Control (DLFC)
6"	#000 Brown	(0.70 GPM)	#1 (1.5 GPM)
7"			#2 (2.0 GPM)
8"	#3 (2.4 GPM)		
9"	#4 (3.5 GPM)		
10"	#6 (4.0 GPM)		
12"	#7 (5.0 GPM)		
13"	#2 Blue		none
14"	#3 Yellow		
16"			

Figure 9. Valve Configurations

Automatic Bypass

The regeneration cycle lasts approximately 75 minutes, after which soft water service will be restored. During regeneration, hard water is automatically bypassed for use in the household. Hot water should be used as little as possible during this time to prevent hard water from filling the water heater. This is why automatic regeneration is set for sometime during the night and manual regenerations should be performed when little or no water will be used in the household.

Safety Float

The brine tank is equipped with a safety float which prevents your brine tank from overflowing as a result of a malfunction such as a power failure.

New Sounds

You may notice new sounds as your water softener operates. The regeneration cycle lasts approximately 2-1/2 hours. During this time, you may hear water running intermittently to the drain.

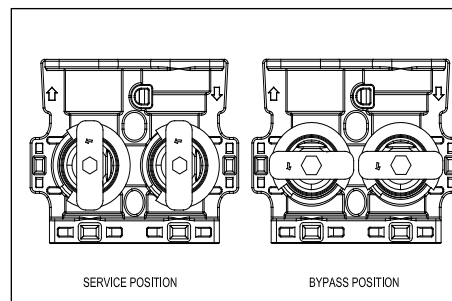

Figure 10. Bypass Installation View

Manual Bypass

In the case of emergency, such as an overflowing brine tank, you can isolate your water softener from the water supply using the bypass valve located at the back of the control. In normal operation the bypass is open with the on/off knobs in line with the inlet and outlet pipes. To isolate the softener, simply rotate the knobs counter clockwise until they lock. You can use your water related fixtures and appliances as the water supply is bypassing the softener. However, the water you use will be hard. To resume soft water service, open bypass valve by rotating the knobs clockwise.

Maintenance

Adding Salt

Use only crystal water softener salt. Check the salt level monthly. It is important to maintain the salt level above the water level. To add salt, simply lift the salt lid and add the salt directly into the brine tank. Be sure the brine well cover is on and fill only to the height of the brine well.

Bridging

Humidity or wrong type of salt may create a cavity between the water and the salt. This action, known as “bridging”, prevents the brine solution from being made, leading to your water supply being hard. If you suspect salt bridging, carefully pound on the outside of the brine tank or pour some warm water over the salt to break up the bridge. This should always be followed up by allowing the unit to use up any remaining salt and then thoroughly cleaning out the brine tank. Allow four hours to produce a brine solution, and then manually regenerate the softener.

Care of Your Softener

To retain the attractive appearance of your new water softener, clean occasionally with mild soap solution. Do not use abrasive cleaners, ammonia or solvents. Never subject your softener to freezing or to temperatures above 120°F.

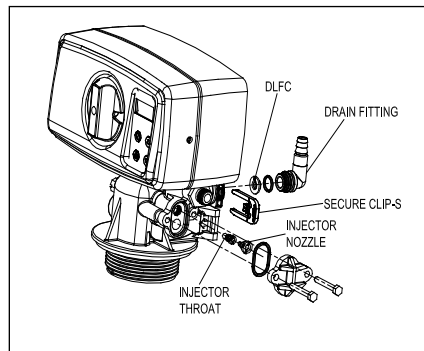

Figure 11. Injector Assembly

Cleaning the Injector Assembly

Sediment, salt and silt will restrict or clog the injector. A clean water supply and pure salt will prevent this from happening.

The injector assembly is located on the right side of the control valve. This assembly is easy to clean.

Shut off the water supply to your softener and reduce the pressure by opening a cold soft water faucet. Using a screwdriver, remove the two screws holding the injector cover to the control valve body. Carefully remove the assembly and disassemble as shown in Figure 6. The injector orifice is removed from the valve body by carefully turning it out with a large screwdriver. Remove the injector throat the same way. Carefully flush all parts including the screen. Use a mild acid such as vinegar or Pro-Rust Out to clean the small holes in the orifice and throat.

Re-assemble using the reverse procedure.

Resin Cleaner

An approved resin cleaner **must** be used on a regular basis if your water supply contains iron. The amount of resin cleaner and frequency of use is determined by the quantity of iron in your water (consult your local representative or follow the directions on the resin package).

Sanitizing Procedure

Care is taken at the factory to keep your water softener clean and sanitary. Materials used to make the softener will not infect or contaminate your water supply, and will not cause bacteria to form or grow. However, during shipping, storage, installing and operating, bacteria could get into the softener. For this reason, sanitizing as follows is suggested when installing.

Sani-System Liquid Sanitizer Concentrate



Item# 80030021—Softener Sanitizer 0.25 fl.oz (24 Pack)

1. Be sure to complete all installation steps, including programming.
2. For effective and complete sanitization, EcoSmart recommends Sani-System Liquid Sanitizer Concentrate. Pour one 0.25 fl. Oz. package into the brine well located in the cabinet tank. (Alternative use 3/4 oz of common 5.25% household bleach)
3. Start an immediate regeneration. If screen is locked, press MENU for 3 seconds to unlock. To initiate an Immediate Regeneration, press the SET / REGEN button for 3 seconds, an option for Delayed or Immediate Regeneration will appear. Press the SET / REGEN button again and delayed will begin flashing, press the down arrow button to have Immediate flash, press the SET / REGEN button and then press the MENU button and the valve will immediately start into manual regeneration.
4. The Softener Sanitizer Solution is drawn into and through the water softener to sanitize it. This sanitizing regeneration is over in about two hours. Then, soft water is available for your use.

NOTE: Sanitizing is recommended by the Water Quality Association for disinfecting. On some water supplies, they suggest periodic sanitizing.

Power Head Exploded View

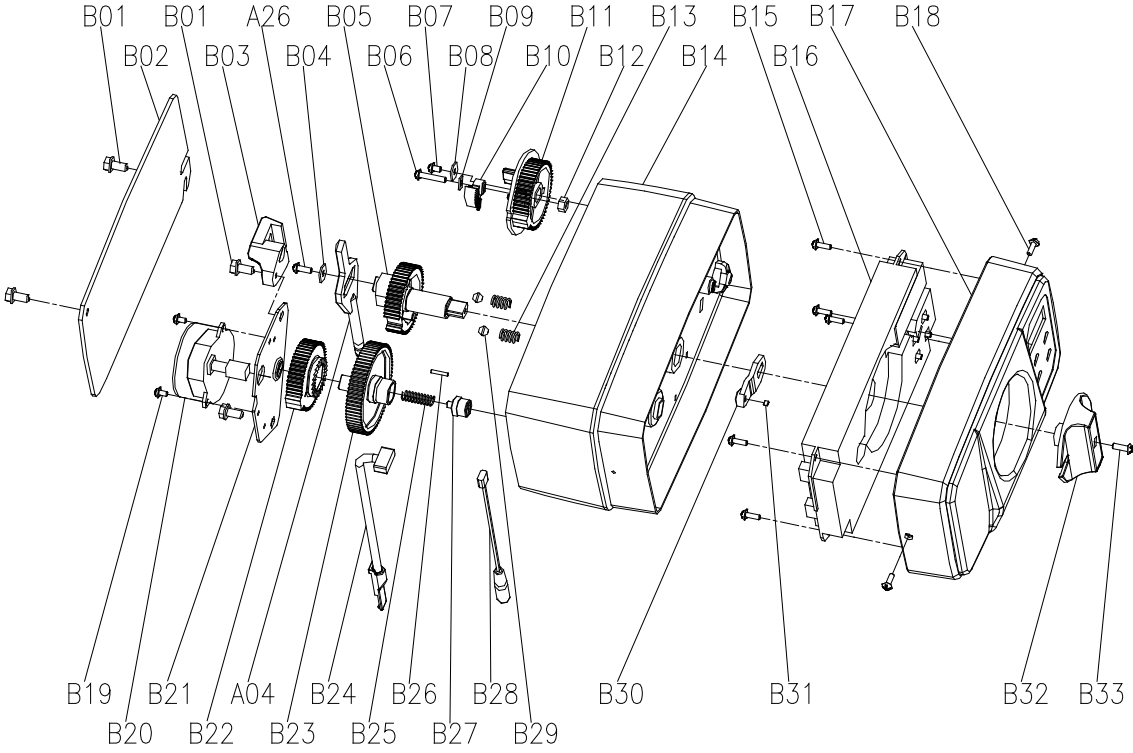

See parts listing on next page (13)

To order replacement parts contact your dealer. For help in locating your dealer please call 1-877-444-3348.

Power Head Parts List

Item No.	Part No.	Part Description	Quantity
B01	5056136	Screw-ST3.5x13(Hexagon with Washer)	4
B02	5056014	Bnt65 Back Cover	1
B03	5010045	Piston Stem Holder	1
A26	13000426	Screw-ST2.9x13(Large Wafer)	1
B04	5056139	Washer-3x13	1
B05	5056005	Main Gear	1
B06	5056083	Screw-M4x14	1
B07	5056166	Screw-ST4.2x12(Large Wafer)	1
B08	5056141	Washer-4x12	1
B09	13111004	Washer-4x9	1
B10	5056016	Refill Regulator	1
B11	5056015	Brine Gear	1
B12	5056089	Nut-M4	1
B13	5056095	Spring Detent	2
B14	5056001	Bnt65 Housing	1
B15	5010037	Screw-ST2.9x10	5
B16	5056504	Bnt165 Pcb	1
B17	5056500	Bnt165 Front Cover	1
	5056505	Bnt165 Operation Label	1
	5056506	Bnt165 Regen. Label	1
B18	5056509	Screw-ST2.9x10(CSK)	2
B19	5056082	Screw-M3x5	2
B20	5056510	Motor-12v/2rpm	1
	11700005	Wire Connector	2
B21	5056045	Motor Mounting Plate	1
B22	5056501	Bnt165 Drive Gear	1
A04	5010081	Bnt65 Piston Rod	1
B23	5056002	Idler Gear	1
B24	5010031	Meter Assembly	1
	5010046	Meter Strain Relief	1
B25	5056094	Spring Idler	1
B26	5056098	Motor Pin	1
B27	5056502	Spring Retainer	1
B28	5056507	Bnt165 Power Cable	1
	5056013	Bnt65 Power Strain Relief	1
B29	5056092	Ball-1/4inch	2
B30	5056503	Magnet Holder	1
B31	5010023	Magnet- \varnothing 3x2.7	1
B32	5056008	Bnt65 Knob	1
	5056111	Bnt65 Knob Label	1
B33	5056084	Screw-ST3.5x13	1

Control Valve Exploded View

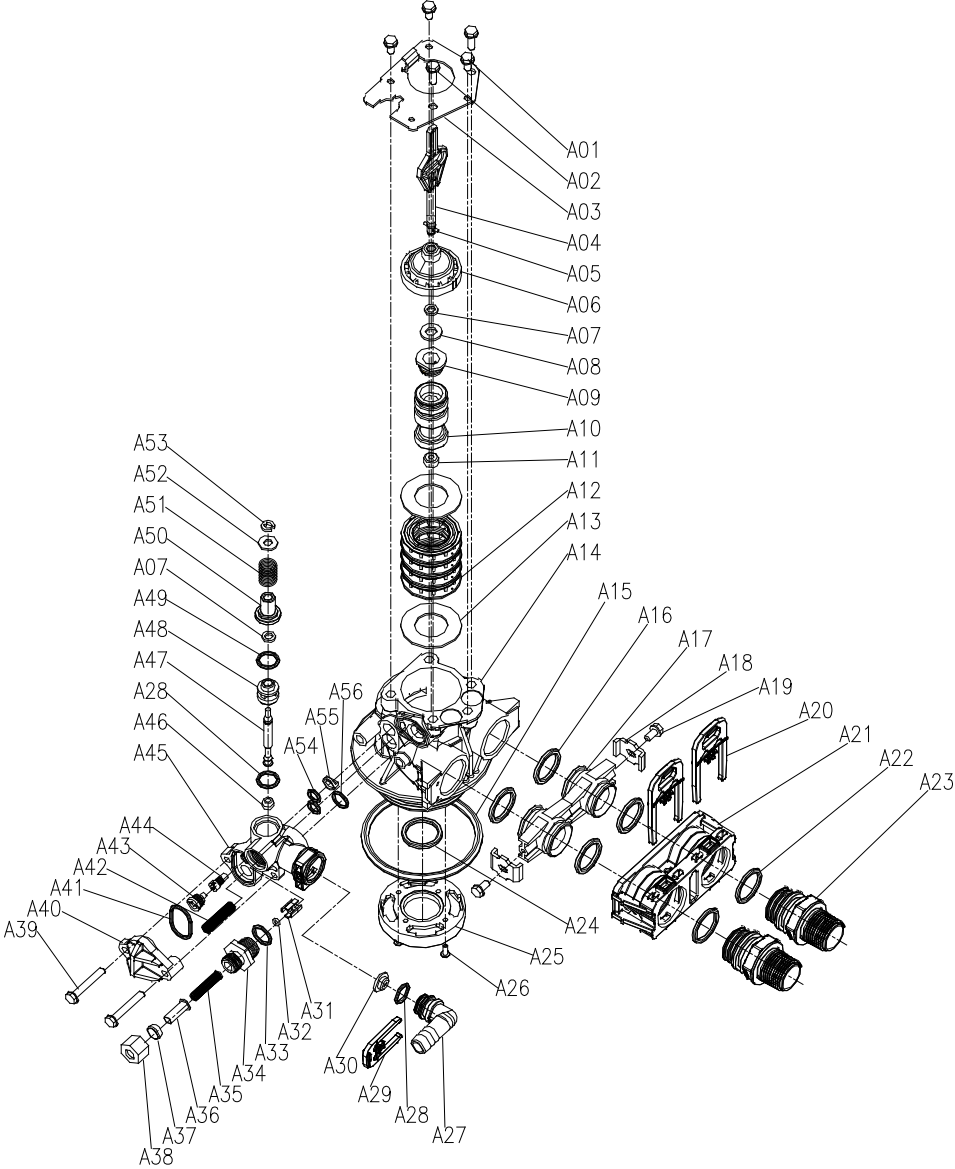

See parts listing on next page (15)

Control Valve Parts List

Item No.	Part No.	Part Discription	Quantity
A01	05056087	Screw-M5×12(Hexagon)	3
A02	05056088	Screw-M5×16(Hexagon with Washer)	2
A03	05056047	End Plug Retainer	1
A04	05010081	Bnt65 Piston Rod	1
A05	05056097	Piston Pin	1
A06	05056023	End Plug	1
A07	05056070	Quad Ring	2
A08	05056024	End Plug Washer	1
A09	05056022	Piston Retainer	1
A10	05056181	Piston (Electrical)	1
A11	05056104	Muffler	1
A12	05056021	Spacer	4
A13	05056073	Seal	5
A14	05056019	Bnt65 Valve Body	1
A15	05056063	O-ring-φ78.74×5.33	1
A16	05056129	O-ring-φ23×3	4
A17	05056025	Adaptor Coupling	2
A18	05056044	Adaptor Clip	2
A19	05056090	Screw-ST4.2×13(Hexagon with Washer)	2
A20	21709003	Secure Clip	2
A21	05056140	Valve Connector	1
A22	05056065	O-ring-φ23.6×2.65	2
A23	21319006	Screw Adaptor	2
A24	26010103	O-ring-φ25×3.55	1
A25	07060007	Valve Bottom Connector	1
A26	13000426	Screw-ST2.9×13(Large Wafer)	2
A27	05010082	Drain Fitting	1
A28	05056134	O-Ring-φ12×2	1
A29	05056172	Secure Clip-S	1
A30	05056186	DLFC-2#	1
A32	05056035	BLFC Button Retainer	1
A33	05056191	BLFC-2#	1
A34	05056138	O-Ring-φ14×1.8	1
A35	05056100B	BLFC Fitting	1
A36	05056106	Brine Line Screen	1
A37	05056107	BLFC Tube Insert	1
A38	05056033	BLFC Ferrule	1
A39	05056108	BLFC Fitting Nut	1
A40	05056086	Screw-M5×30(Hexagon with Washer)	2
A41	05056029	Injector Cover	1
A42	05056072	O-Ring-φ24×2	1
A43	05056103	Injector Screen	1
A44	05056027	Injector Nozzle	1
A45	05056028	Injctor Throat	1
A46	05056177	Injector Body	1
A47	05056075	Injector Seat	1
A48	05056134	O-Ring-φ12×2	1
A49	05056054	Injector Stem	1
A50	05056031	Injector Spacer	1
A51	05056081	O-Ring-φ12.5×1.8	1
A52	05056030	Injector Cap	1
A53	05056093	Injector Screen	1
A54	05010049	Special Washer	1
A55	05056105	Retaining Ring	1
A56	05056067	O-Ring-φ7.8×1.9)	2
A57	05056037	Air Disperser	1
A58	05056066	O-Ring-φ11×2	1

Trouble Shooting

Issue	Possible Cause	Possible Solution
A. Unit fails to initiate a regeneration cycle.	1. No power supply.	Check electrical service, fuse, etc.
	2. Defective circuit board.	Replace faulty parts.
	3. Power failure.	Reset time of day.
B. Water is hard.	1. By-pass valve open.	Close by-pass valve.
	2. Out of salt.	Add salt to tank.
	3. Plugged injector / screen.	Clean parts.
	4. Flow of water blocked to brine tank.	Check brine tank refill rate.
	5. Hard water in hot water tank.	Repeat flushing of hot water tank required.
	6. Leak between valve and central tube.	Check if central tube is cracked or o-ring is damaged. Replace faulty parts.
	7. Internal valve leak.	Replace valve seals, spacer, and piston assembly.
C. Salt use is high.	1. Refill time is too high.	Check refill time setting.
D. Low water pressure.	1. Iron or scale build up in line feeding unit.	Clean pipes.
	2. Iron build up inside valve or tank.	Clean control and add resin cleaner to clean bed. Increase regeneration frequency.
	3. Inlet of control plugged due to foreign material.	Remove piston and clean control valve.
E. Resin in drain line.	1. Air in water system.	Check well system for proper air eliminator control.
	2. Incorrect drain line flow control (DLFC) button.	Check for proper flow rate.
F. Too much water in brine tank.	1. Plugged injector or screen.	Clean parts.
	2. Valve not regenerating.	Replace circuit board, motor, or control.
	3. Foreign material in brine valve.	Clean parts.
G. Unit fails to draw brine.	1. Drain line flow control is plugged.	Clean parts.
	2. Injector or screen is plugged.	Clean parts.
	3. Inlet pressure too low.	Increase pressure to 25 PSI.
	4. Internal valve leak.	Replace seals, spacers, and piston assembly.
H. Valve continuously cycles.	1. Defective position sensor PCB.	Replace faulty parts.
I. Flow to drain continuously.	1. Valve settings incorrect.	Check valve settings.
	2. Foreign material in control valve.	Clean control.
	3. Internal leak.	Replace seals, spacers, and piston assembly.

Manufacturers Warranty

Canature North America Inc. warrants that your new water conditioner is built of quality material and workmanship. When properly installed and maintained, it will give years of trouble free service.

Five Year Complete Parts Warranty:

Canature North America Inc. will replace any part which fails within 60 months from date of manufacture, as indicated by the serial number, provided the failure is due to a defect in material or workmanship. The only exception shall be when proof of purchase or installation is provided and then the warranty period shall be from the date thereof.

Ten Year Warranty on Mineral Tanks and Brine Tanks:

Canature North America Inc. will provide a replacement mineral tank or brine tank to any original equipment purchaser in possession of a tank that fails within 120 months, provided that the water conditioner is at all times operated in accordance with specifications and not subject to freezing.

General Provisions:

Damage to any part of this water conditioner or filter as a result of misuse, misapplication, neglect, alteration, accident, installation or operation contrary to our printed instructions, damage to ion exchange resin and seals caused by chlorine / chloramines in the water supply, or damage caused by any force of nature is not covered in this warranty. We will repair or replace defective parts if our warranty department determines it to be defective under the terms of this warranty. Canature assumes no responsibility for consequential damage, labour or expense incurred as a result of a defect or failure.