

565 HIMTLC PLUS

Owners Manual

1. **Read all instructions carefully before operation.**
2. **Avoid pinched o-rings during installation by applying (provided with install kit) NSF certified lubricant to all seals.**
3. **This system is not intended for treating water that is microbiologically unsafe or of unknown quality without adequate disinfection before or after the system.**
4. **Backwash for 30 minutes after installing in order to allow the layers to settle to their appropriate height.**

REVISION # 0
REVISION DATE March 16, 2017
80150383

Canadian Head Office
855 Park St.
Regina, SK. S4N 4Y4

U.S. Head Office
9760 Mayflower Park Drive,
Suite 110
Carmel, IN 46032

Table of Contents

	PAGE
Unpacking / Inspection	2
Safety Guide	2
Proper Installation	3
Specification	4
Before Starting Installation	4
Installation Instructions	6
System Start Up	8
Programming Instructions	9
About The System	10
Maintenance	12
Sanitizing Procedure	15
Main Repair Parts	17
Trouble Shooting	23
Warranty	24

Unpacking / Inspection

Be sure to check the entire Speciality system for any shipping damage or parts loss. Also note damage to the shipping cartons. Contact the transportation company for all damage and loss claims. The manufacturer is not responsible for damages in transit.

Small parts, needed to install the Speciality System, are in a parts bag. To avoid loss of the small parts, keep them in the parts bag until you are ready to use them.

Safety Guide

For your safety, the information in this manual must be followed to minimize the risk of electric shock, property damage or personal injury.

- Check and comply with your provincial / state and local codes. You must follow these guidelines.
- Use care when handling the Speciality System. Do not turn upside down, drop, drag or set on sharp protrusions.
- The Speciality system works on 12 volt-60 Hz electrical power only. Be sure to use only the included transformer.
- Transformer must be plugged into an indoor 120 volt, grounded outlet only.
- Use clean water softening salts only, at least 99.5% pure. NUGGET, PELLET or coarse SOLAR salts are recommended. Do not use rock, block, granulated or ice cream making salts. They contain dirt and sediments, or mush and cake, and will create maintenance problems.
- Keep the salt lid in place on the Speciality System unless servicing the unit or refilling with salt.
- **WARNING:** This system is not intended for treating water that is microbiologically unsafe or of unknown quality without adequate disinfection before or after the system.

Proper Installation

This speciality system must be properly installed and located in accordance with the Installation Instructions before it is used.

- **Do not** install or store where it will not be exposed to temperatures below freezing or exposed to any type of weather. Water freezing in the system will break it. Do not attempt to treat water over 100°F.
- **Do not** install in direct sunlight. Excessive sun or heat may cause distortion or other damage to non-metallic parts.
- Properly ground to conform with all governing codes and ordinances.
- Use only *lead-free solder and flux* for all sweat-solder connections, as required by state and federal codes.
- Maximum allowable inlet water pressure is 125 psi. If daytime pressure is over 80 psi, night time pressure may exceed the maximum. Use a pressure reducing valve to reduce the flow if necessary.
- Speciality System resins may degrade in the presence of chlorine above 2 ppm. If you have chlorine in excess of this amount, you may experience reduced life of the resin. In these conditions, you may wish to consider purchasing a whole house carbon filter Speciality System system with a chlorine reducing media.
- **WARNING:** Discard all unused parts and packaging material after installation. Small parts remaining after the installation could be a choke hazard.

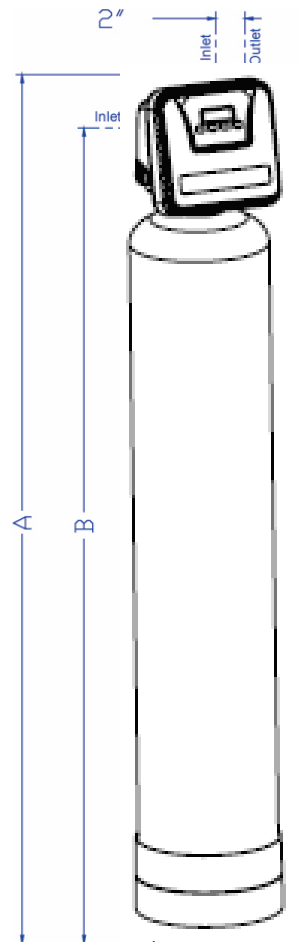

	A	B	C
1054	58.23"	56.54"	10"
1252	58.23"	54.54"	12"
1354	58.23"	56.54"	13"
1485	69.23"	67.54"	14"

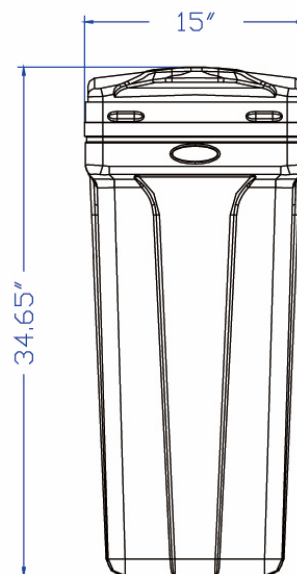

Specifications

Specifications	HIMTLCPLUS-150	HIMTLCPLUS-200	HIMTLCPLUS-250	HIMTLCPLUS-300
Salt Used - Per Regeneration	9.0 lbs	12.0 lbs	15.0 lbs	18.0 lbs
Water Used - Regeneration	74.6 gal	98.9 gal	126.6 gal	153.0 gal
Hardness Removal - Grains	17,100	22,800	28,500	34,200
Advanced Exchange Media (ft ³)	1.32ft ³	1.76 ft ³	2.20 ft ³	2.64 ft ³
Tank Size	10x54	12x52	13x54	14x65
Top Cone	Yes	Yes	Yes	Yes
Tank Jacket / Media Loaded	Yes	No	No	No
Brine Tank (Inches)	20.3 x 37.4	20.3 x 37.4	20.3 x 37.4	23.0 x 40.5
Salt Storage Capacity	350 lbs	350 lbs	350 lbs	420 lbs
Critical Service Flow Rate	4-6 gpm	6-8 gpm	8-10 gpm	10-12 gpm
Back Wash Flow Rate	2.4 gpm	4.0 gpm	5.0 gpm	7.0 gpm
Shipping Weight	141 lbs	158 lbs	198 lbs	244 lbs
Hardness	Maximum 45 gpg			
Iron	Maximum 15 ppm			
Manganese	Maximum 3 ppm			
Tannins	Maximum 5 ppm / TOC 17 ppm			
Ammonium	Maximum 4 ppm			
pH	5-9			
Other	Free Chlorine < 1 ppm, TDS < 4000 ppm			
Regeneration Type	Down Flow			
Plumbing Connections	Includes 3/4" 90°Elbows & 1" Straight NPT			
Electrical Requirements	Input 120V 60 Hz - Output 12V 650mA			
Water Temperature	Min 39 - Max. 100° F			
Water Pressure	Min. 20 - Max. 125 psi			

- Continuous operation at flow rates greater than the service flow rate may affect capacity and efficiency performance.
- The manufacturer reserves the right to make product improvements which may deviate from the specifications and descriptions stated herein, without obligation to change previously manufactured products or to note the change.

Where To Install The Speciality Unit

- Place the speciality unit as close as possible to the pressure tank (well system) or water meter (city water).
- Place the Speciality System as close as possible to a floor drain, or other acceptable drain point (laundry tub, sump, stand-pipe, etc.).
- Connect the Speciality System to the main water supply pipe BEFORE the water heater. **DO NOT RUN HOT WATER THROUGH THE SPECIALITY SYSTEM.** Temperature of water passing through the Speciality System must be less than 100 deg. F.
- Keep outside faucets on hard water to save soft water and salt.
- Do not install the Speciality System in a place where it could freeze. **Damage caused by freezing is not covered by the warranty.**
- Put the Speciality System in a place water damage is least likely to occur if a leak develops. The manufacturer will not repair or pay for water damage.
- A 120 volt electric outlet, to plug the included transformer into, is needed within 6 feet of the Speciality System. The transformer has an attached 6 foot power cable. **Be sure the electric outlet and transformer are in an inside location, to protect from wet weather.**
- If installing in an outside location, you must take the steps necessary to assure the Speciality System, installation plumbing, wiring, etc., are as well protected from the elements, contamination, vandalism, etc., as when installed indoors.
- **Keep the Speciality System out of di-**

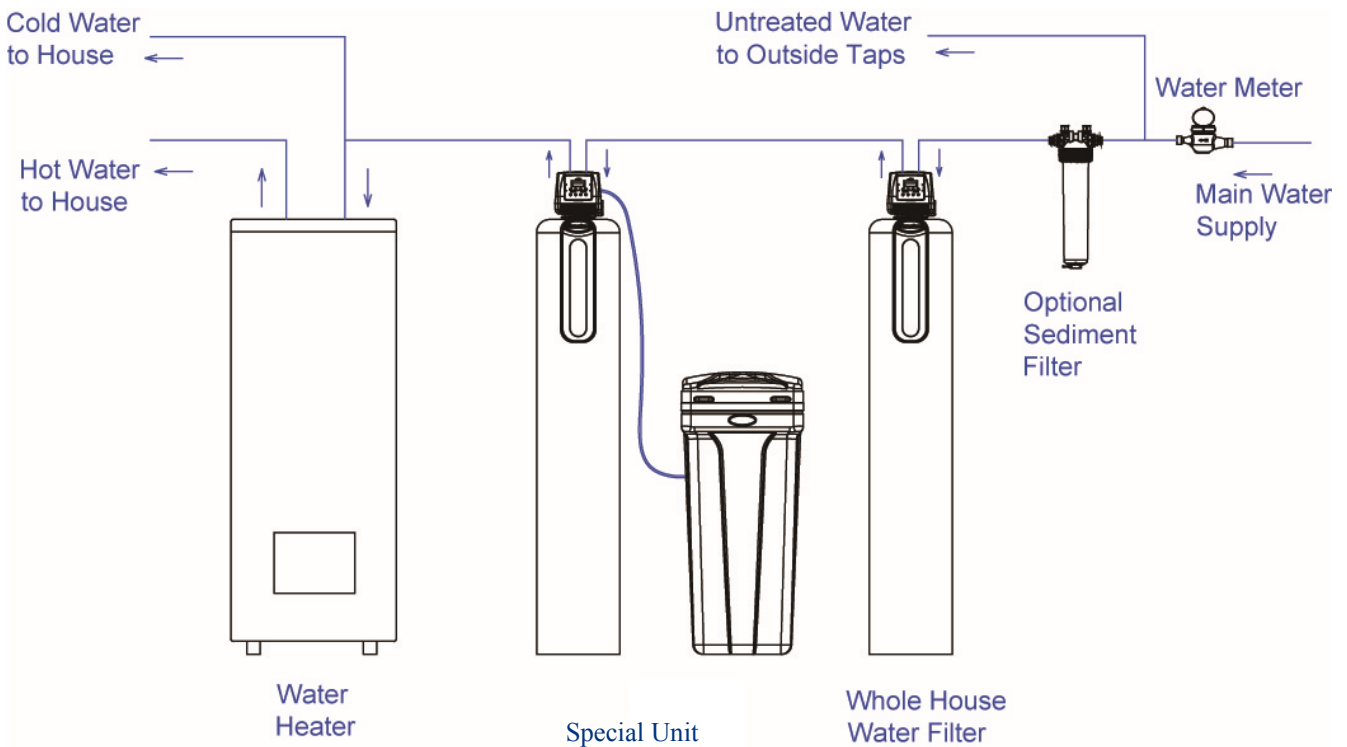

Before Starting Installation

Tools, Pipe, and Fittings, Other Materials

- Pliers
- Screwdriver
- Teflon tape
- Razor knife
- Two adjustable wrenches
- Additional tools may be required if modification to home plumbing is required.
- Plastic inlet and outlet fittings are included with the Speciality System. To maintain full valve flow, 3/4" or 1" pipes to and from the Speciality System fittings are recommended. You should maintain the same, or larger, pipe size as the water supply pipe, up to the Speciality System inlet and outlet.
- Use copper, brass, or PEX pipe and fittings.
- Some codes may also allow PVC plastic pipe.
- ALWAYS install the included bypass valve, or 3 shut-off valves. Bypass valves let you turn off water to the Speciality System for repairs if needed, but still have water in the house pipes.
- 5/8" OD drain line is needed for the valve drain. A 10' length of hose is included with some models.
- A length of 5/8" OD drain line tubing is needed for the brine tank over flow fitting (optional).
- Nugget or pellet water Speciality System

Key Points

- Pay close attention to critical flow rates. If system flow rates exceed the specification for critical flow rates you may lose capacity and experience breakthrough for Iron, Mn, or Tannins. To be safe choose one size larger when sizing.
- Any oxidative pre-treatment such as air or chemicals is unnecessary and should be avoided.
- Cleaning chemicals are unnecessary and should be avoided as they may strip important coatings from the media reducing its effectiveness.
- High amounts of Ferric Iron (precipitated iron) or rust will not be filtered as the HIMTLC PLUS unit uses the ion exchange process. It may be necessary to add a filter ahead of the system to remove excess Ferric Iron or rust.
- It's very important to not run the system out of salt. In the event the system does run out of salt and the unit is completely exhausted, an over night "soak" is recommended to clean the media. See next page for procedure.
- Always be sure the salt tank has enough salt. The salt should always be above the water level in the tank. If you can see water it's time to add salt. Keeping the salt above the water level insures a very high saturated brine solution and a good regeneration.
- On very bad problem water, the "soak" procedure may be performed regularly (monthly or as needed) to keep the media in good working condition.
- Units are designed to work with down flow valves only.
- A good back wash (15 minutes) is required as the friction of the media rubbing together releases the Iron and Manganese compounds from the surface of the media.

Clean / Soak Procedure

- 1.** Add 3-4 gallons of water to brine tank. (Be sure that salt level is above water level at all times)
- 2.** Allow minimum 2 hours for the water to absorb the salt.
- 3.** Start a manual regeneration.
- 4.** Watch as the water level is decreased in the brine tank. When the water in the brine tank has been drawn into the mineral tank (10-15 minutes), unplug the valve.
- 5.** Turn the bypass handles to the bypass mode.
- 6.** Allow the unit to sit over night (8 hours). This allows a long contact time with the brine and media.
- 7.** After 8 hours plug the power back in.
- 8.** Turn the bypass handles to the service mode.
- 9.** Allow the valve to complete its remaining portion of the regeneration

Installation Instructions

1. If your hot water tank is electric, turn off the power to it to avoid damage to the element in the tank.
2. If you have a private well, turn the power off to the pump and then shut off the main water shut off valve. If you have municipal water, simply shut off the main valve. Go to the faucet, (preferably on the lowest floor of the house) turn on the cold water until all pressure is relieved and the flow of water stops.
3. Locate the Speciality System tank and brine tank close to a drain where the system will be installed. The surface should be clean and level.
4. Connect the inlet and outlet of the Speciality System using appropriate fittings. Perform all plumbing according to local plumbing codes.
 - Use a ½" minimum pipe or tubing size for the drain line
 - **ON COPPER PLUMBING SYSTEMS BE SURE TO INSTALL A GROUNDING WIRE BETWEEN THE INLET AND OUTLET PIPING TO MAINTAIN GROUNDING.**

Any solder joints near the valve must be done before connecting any piping to the valve. Always leave at least 6" (152 mm) between the valve and joints when soldering pipes that are connected to the valve. Failure to do this could cause damage to the valve.

5. Connect the drain hose (10 ft included) to the valve and secure it with a hose clamp (also included). Run the drain hose to the nearest laundry tub or drain pipe. This can be ran up overhead or down along the floor. If running the drain line more than 20 ft overhead, it is recommended to increase the hose size to 3/4". NEVER MAKE A DIRECT CONNECTION INTO A WASTE DRAIN. A PHYSICAL AIR GAP OF AT LEAST 1.5" SHOULD BE USED TO AVOID BACTERIA AND WASTEWATER TRAVELLING BACK THROUGH THE DRAIN LINE INTO THE SPECIALITY SYSTEM.
6. Using the Allen Key (included), place the unit in the bypass position. Slowly turn on the main water supply. At the nearest cold treated water tap nearby remove the faucet screen, open the faucet and let water run a few minutes or until the system is free of any air or foreign material resulting from the plumbing work.
7. Make sure there are no leaks in the plumbing system before proceeding. Close the water tap when water runs clean.
8. Open the brine tank / cabinet salt lid and add water as per the below chart. Do not add salt to the brine tank at this time.
9. Proceed to start up instructions.

Note: The unit is not ready for service until you complete the start-up instructions.

Installation

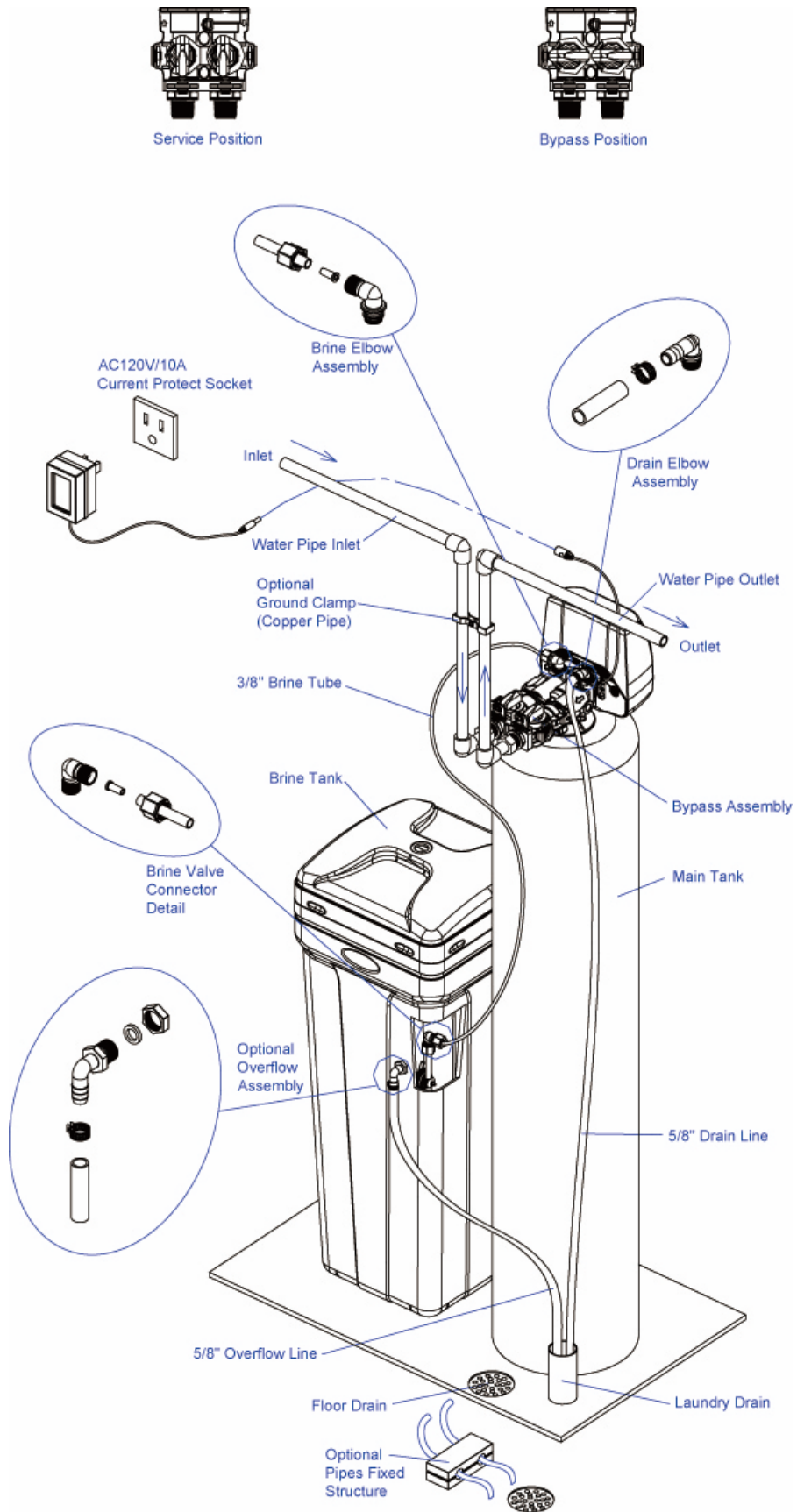

System Start-Up

Key Pad Configuration

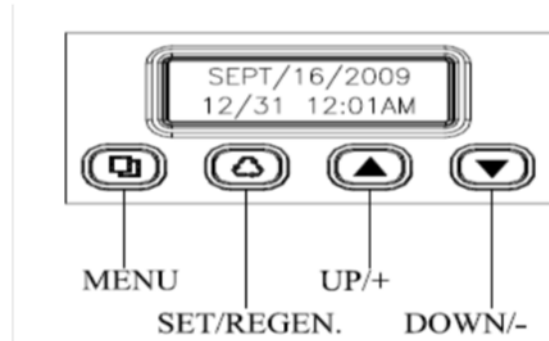

Manual Regeneration (Step / Cycle Valve)

DELAYED REGENERATION

Press and release the MANUAL REGEN. Button to set a delayed regeneration that will occur at the regeneration time. The main display page will show DELAYED REGEN ON. To cancel press and release the MANUAL REGEN. Button. The main display page will show DELAYED REGEN OFF.

IMMEDIATE REGENERATION













To start an immediate regeneration (or step valve through each position), press and hold the MANUAL REGEN. Button for 3 seconds (until beeps). The valve will start an immediate regeneration. Press any key to skip to the next cycle.

Start-up Instructions



1. Plug the power transformer into an approved power source. Connect the power cord to the valve.
2. When power is supplied to the control, the screen will display "INITIALIZING WAIT PLEASE" while it finds the service position.
3. Manually step the valve past the BRINE position to the BACKWASH position. If screen is locked, press SETTINGS for 3 seconds to unlock. Press and hold the MANUL REGEN. Key for 3 seconds. Press any key to skip the BRINE cycle.
4. Once in the BACKWASH cycle, open the inlet on the bypass valve slowly and allow water to enter the unit. Allow all air to escape from the unit before turning the water on fully then allow water to run to drain for 30 minutes in order to allow the layers to settle to their appropriate height.
5. Press any button to advance to the RINSE position. Check the drain line flow. Allow the water to run for 3-4 minutes or until the water is clear.
6. Press any button to advance to the REFILL position. Check that the valve is filling water into the brine tank. Allow the valve to refill for the full amount of time as displayed on the screen to insure a proper brine solution for the next regeneration.
7. The valve will automatically advance to the SERVICE position. Open the outlet valve on the bypass, then open the nearest treated water faucet and allow the water to run until clear, close the tap and replace the faucet screen.
8. Add salt into the cabinet / brine tank.
9. Program unit.

Level I User Programming



Setting Current Time

1. If screen is locked, press “ MENU” for 3 seconds to unlock. Press “ MENU” again to enter level one programming mode and adjust CURRENT TIME.
2. Press “ SET/REGEN” to adjust hours. When you have entered the change value mode, the cursor will blink. Press “ or  UP OR DOWN” arrows to change the hour values. Press “ SET/REGEN” again to accept the hour value and advance to change the minutes value. Press “ or  UP OR DOWN” arrows to change the minute values. Press “ SET/REGEN” again to accept the minute values and advance to adjust the AM/PM values. Press “ or  UP OR DOWN” to change the AM/PM value. Press “ SET/REGEN” again to accept the AM/PM value and exit. When you have exited the change value mode, the cursor will stop flashing.





Setting Current Date

1. Press “ DOWN” to advance to CURRENT DATE.
2. Using the same procedure as setting the time, press “ SET/REGEN” to enter value change mode.





Setting Number of People

1. Press “ DOWN” to advance to NUMBER OF PEOPLE.
2. Press the “ SET/REGEN” to change the value. Press up or down arrows to change the values.

Setting Water Hardness

1. Press “ DOWN” to advance to WATER HARDNESS.
2. Press the “ SET/REGEN” to change the value. Press “ or  UP OR DOWN” to change the values.

Setting Vacation Mode

1. Press “ DOWN” to advance to VACATION MODE.
2. Press the “ SET/REGEN” to change the value. Press “ or  UP OR DOWN” to change the values.

Exiting Level One User Program Mode

At any time, press the “ MENU” to accept all changes and return to main page display.

Level I User Program Mode		
PARAMETER	OPTIONS	DESCRIPTION
1	CURRENT TIME	This option is the current time of day.
2	CURRENT DATE	This option is the current date. The date is used to track the last time the system regenerated.
3	NUMBER PEOPLE	This value is the number of people living in the home. It is used to calculate the amount of water needed for daily use and the reserve capacity of the system.
4	WATER HARDNESS	This value is the maximum water hardness in grains per gallon of the raw water supply. It is used to calculate the system capacity.
5	Yes	This function may be activated by the user during a prolonged absence such as vacation. The system will perform a brief backwash and rinse based on the advanced setting. The purpose is to keep the water fresh in the softener tank and plumbing system.
	No	

About The System

Control Operation During A Power Failure

In the event of a power failure, the valve will keep track of the time and day for 48 hours. The programmed settings are stored in a non-volatile memory and will not be lost during a power failure. If power fails while the unit is in regeneration, the valve will finish regeneration from the point it is at once power is restored. If the valve misses a scheduled regeneration due to a power failure, it will queue a regeneration at the next regeneration time once power is restored.

Safety Float

The brine tank is equipped with a safety float which prevents your brine tank from overflowing as a result of a malfunction such as a power failure.

Main Display

The main display page will pause on the Date and Time page for 5 seconds. Then it will continually scroll through all of the system diagnostic display pages. Depending on the Valve Type some pages will not be displayed. To manually scroll through the diagnostics, press the down or up key. To reset the TOTAL REGENS, TOTAL GALLONS OVER RUN TOTAL, or PEAK flow rates, press and hold the MENU until the value changes to zero.

PARAMETER	DESCRIPTION
JULY/17/2012 8:30 PM	Month, Day, Year, Time
TOTAL 1,500 GAL REMAIN 1,200 GAL	The total amount is the system capacity when fully regenerated. The remaining is the capacity left in the system.
PEOPLE 2 RESERVE 150 GAL	Number of people in the household and the calculated reserve capacity. When remaining reaches reserve capacity a regeneration will be scheduled.
EST. DAYS TO NEXT REGEN 06 DAYS	The estimated number of days until the next regeneration will occur.
LAST REGEN 9/24/12	The date of the last regeneration.
TOTAL REGENS 10	The total number of regenerations.
TOTAL GALLONS 001590 GAL	The total amount of gallons treated by the system.
OVER RUN TOTAL 0500 GAL	The total amount of water that has exceeded the system capacity over the last 4 regenerations. When remaining goes to zero, the gallons used will be added to over run total.
CURRENT 1.5 GPM PEAK 6.5 GPM	The current flow rate and the peak flow rate since the last regeneration.
DELAYED REGEN OFF	Advises whether a delayed regeneration has been scheduled manually or automatically.
REGEN TIME 2:00 AM	The current setting for regeneration time.
REFILL TIME 3:00 MIN	The current calculated refill time.
VALVE MODE SOFTENER UF	The current setting of the valve mode.

New Sounds

You may notice new sounds as your water Speciality System operates. The regeneration cycle lasts up to 180 minutes. During this time, you may hear water running intermittently to

Regeneration Process

When the system capacity is near exhausted, a regeneration is necessary to restore the system to full capacity. The table below explains the regeneration steps.

Step	Name	Description
#1	Back Wash	Fresh water is introduced to the bottom of the tank flowing upwards expanding the ion exchange resin to rinse out any dirt or small particles to the drain and to un-compact the bed to restore full service flow rates.
#2	Brine	The brine solution is introduced slowly from the top of the tank flowing down through the ion exchange resin pushing the hardness out to drain and restoring system capacity.
#4	Rinse	Fresh water is introduced from the top of the tank flowing down through the ion exchange resin rinsing any excess brine solution out to the drain.
#5	Refill	Fresh water is added to the salt tank to prepare and insure fully saturated brine for the next regeneration.

Automatic Hard Water Bypass During Regeneration

The regeneration cycle can last 30 to 180 minutes, after which soft water service will be restored. During regeneration, hard water is automatically bypassed for use in the household. Hot water should be used as little as possible during this time to prevent hard water from filling the water heater. This is why automatic regeneration is set for sometime during the night and manual regenerations should be performed when little or no water will be used in the household.

Normal regeneration time is 2:00 AM.

System Configuration

Suggested Downflow Valve Configurations			
Tank Size (Diameter)	Injector Set	Brine Line Flow Control (BLFC)	Drain Line Flow Control
10"	#1 White	0.7 GPM	#3 (2.4 GPM)
12"	#2 Blue	0.7 GPM	#6 (4.0 GPM)
13"	#2 Blue	0.7 GPM	#A (5.0 GPM)
14"	#3 Yellow	0.7 GPM	#B (7.0 GPM)

Manual Bypass

In the case of emergency, such as an overflowing brine tank, you can isolate your water Speciality System from the water supply using the bypass valve located at the back of the control. In normal operation the bypass is open with the on/off knobs in line with the inlet and outlet pipes.

To isolate the Speciality System, simply rotate the knobs clockwise (as indicated by the word BYPASS and arrow) until they lock. You can use your water related fixtures and appliances as the water supply is bypassing the Speciality System. However, the water you use will be hard. To resume soft water service, open bypass valve by rotating the knobs coun-

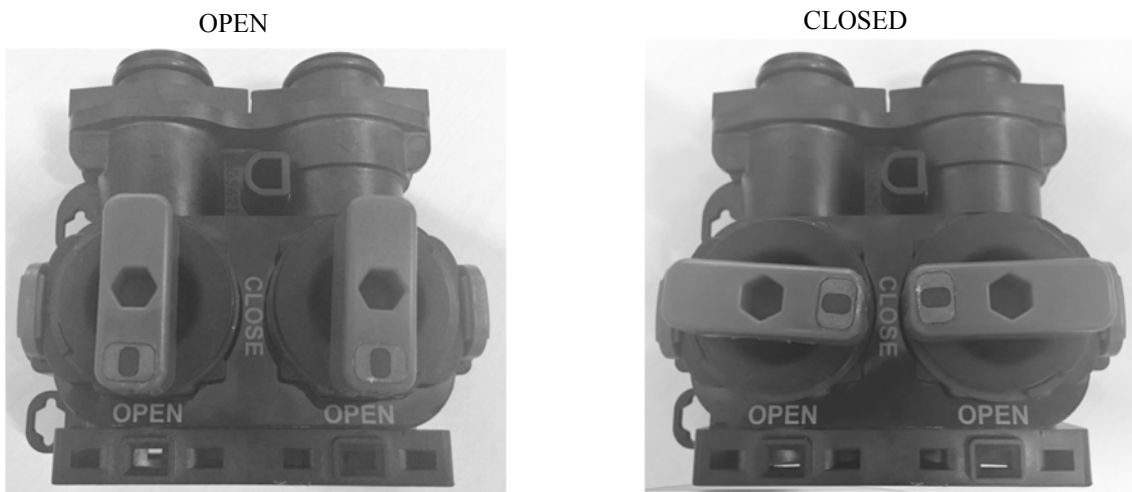

Maintenance

Adding Salt

Use only NUGGET or PELLET water Speciality System salt. Check the salt level monthly. **It is important to maintain the salt level above the water level.** To add salt, simply lift the salt lid and add the salt directly into the brine tank. Be sure the brine well cover is on and fill only to the height of the brine well.

Bridging

Humidity or wrong type of salt may create a cavity between the water and the salt. This action, known as “bridging”, prevents the brine solution from being made, leading to your water supply being hard.

If you suspect salt bridging, carefully pound on the outside of the brine tank or pour some warm water over the salt to break up the bridge. This should always be followed up by allowing the unit to use up any remaining salt and then thoroughly cleaning out the brine tank. Allow two hours to produce a brine solution, then manually regenerate the Speciality

Cleaning or Replacing Injectors

Sediment, salt and silt will restrict or clog the injector. A clean water supply and pure salt will prevent this from happening.

The injector assembly is located on the right side of the control valve. This assembly is easy to clean.

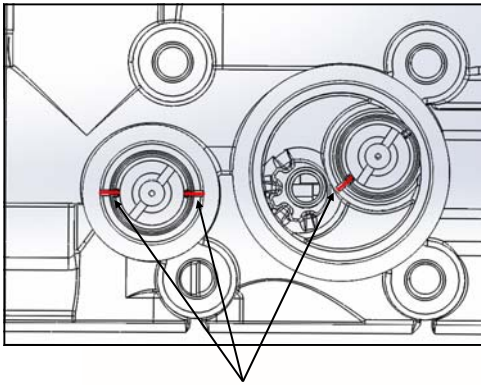

TIP: There are marks on the injector holder that must be lined up to the marks on the valve to fully insert the holder into the hole in the valve body

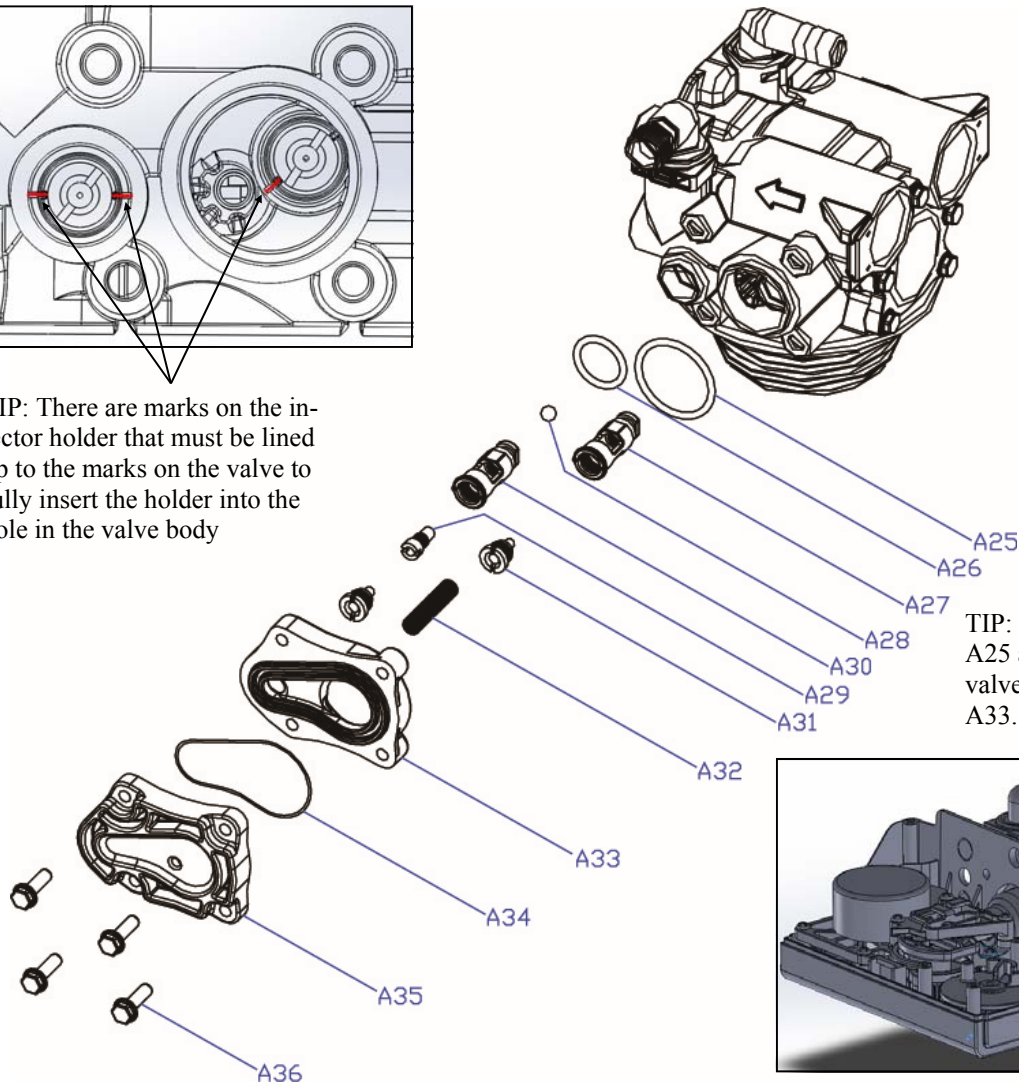

TIP: Place the o-rings A25 and A26 onto the valve before installing A33.

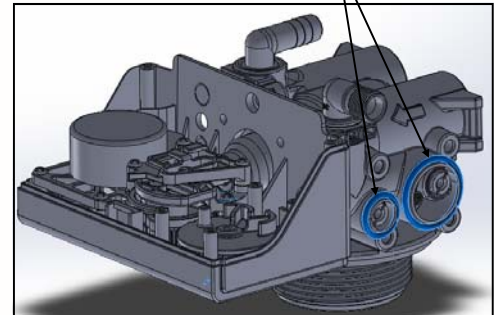

1. Shut off the water supply to your Speciality System and reduce the pressure by opening a cold soft water faucet.
2. Using a screwdriver, remove the four screws holding the injector cover to the control valve body.
3. Carefully remove the assembly and disassemble as shown in above figure.
4. The injector orifice is removed from the valve body by carefully turning it out with a large screwdriver. Remove the injector throat the same way.
5. Carefully flush all parts including the screen. Use a mild acid such as vinegar or Pro-Rust Out to clean the small holes in the orifice and throat.
6. Reassemble using the reverse procedure.

Main Repair Parts - Connectors

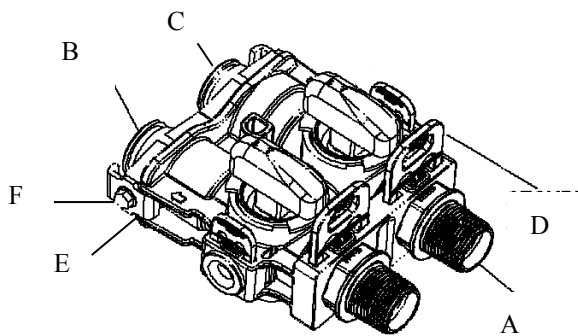
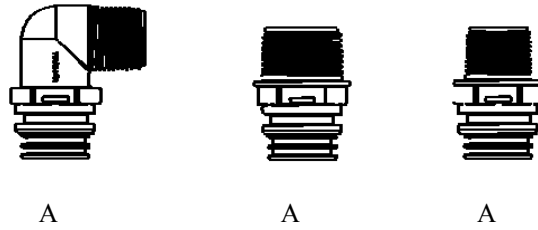

REPLACEMENT PARTS - CONNECTORS			
Replacement Part Number	Part Description	DWG #	Quantity
60010020	3/4" NPT ELBOW	A	2
60010019	1" NPT STRAIGHT	A	2
60010023	3/4" NPT STRAIGHT	A	2
60010079	VALVE COUPLING INLET	B	1
60010101	VALVE COUPLING OUTLET (METER SIDE)	C	1
60010025	PLASTIC SECURE CLIP	D	2
60010046	BYPASS SS CLIP	E	2
21363	BYPASS SS SCREW	F	2

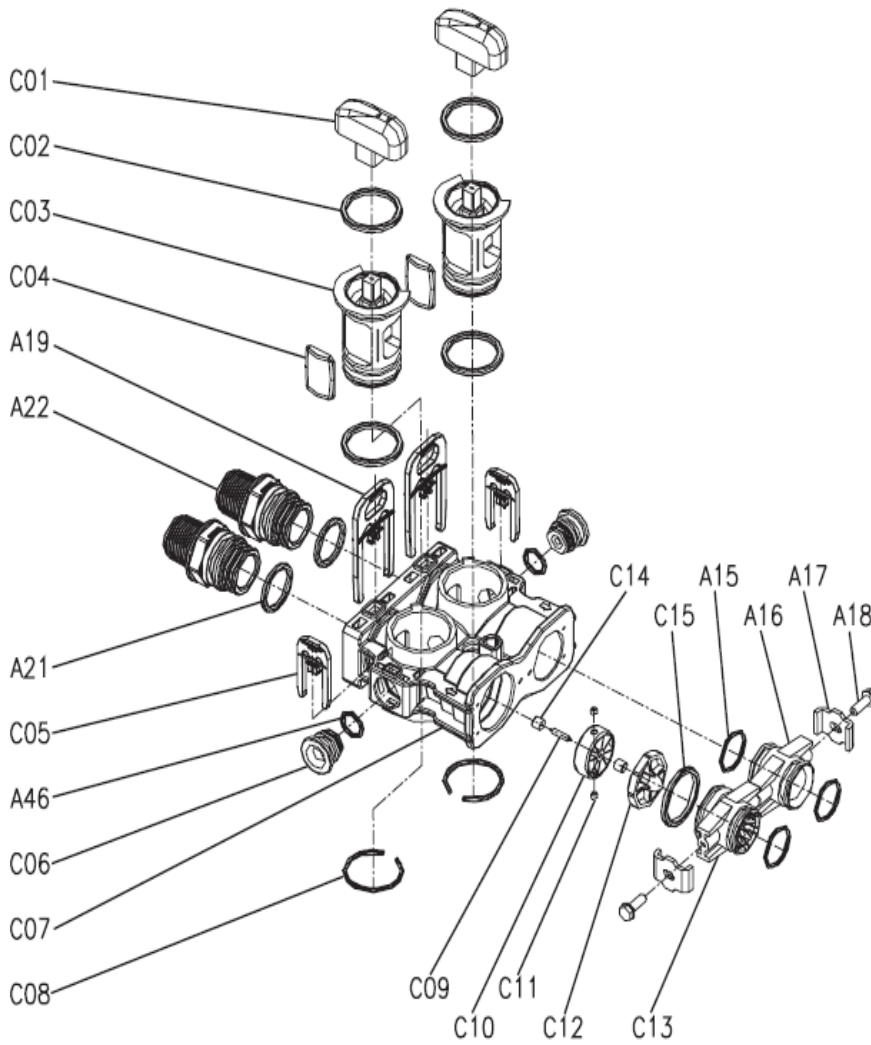

No.	Part # (WaterGroup)	Description	Qty
C01	60095049	Bypass Knob	2
C02	60095611	O-Ring-φ30×2.65	4
C03	60095050	Bypass Plug	2
C04	60095051	Bypass Seal	2
A19	60010025	Secure Clip	2
A22	60010017	Screw Adaptor	2
A21	60010026	O-Ring-φ22.4×3.55	2
C05	60010069	Secure Clip - S	2
A46	60010044	O-Ring-φ12×2	1
C06	60010209	Bulkhead	2
C07	60095052	Bypass Body	1
C08	60095053	Collar - φ32×2.5	2
C09		Impeller Pin	1
C10	60010238	Impeller	1
C11		Magnet-φ4×3	2
C12	60010587	Impeller Holder	1
C13	60010101	Adaptor Distributor	1
C14	60095054	Pin Holder	2
C15	60010102	O-ring-φ27×3	1
A15	60010562	O-ring-φ23×3	3
A16	60010079	Adaptor Coupling	1
A17	60010046	Adaptor Clip	2
A18	21363	Screw-M4×12 (Hexagon with Washer)	2

Replacing Brine Line Flow Control (BLFC)

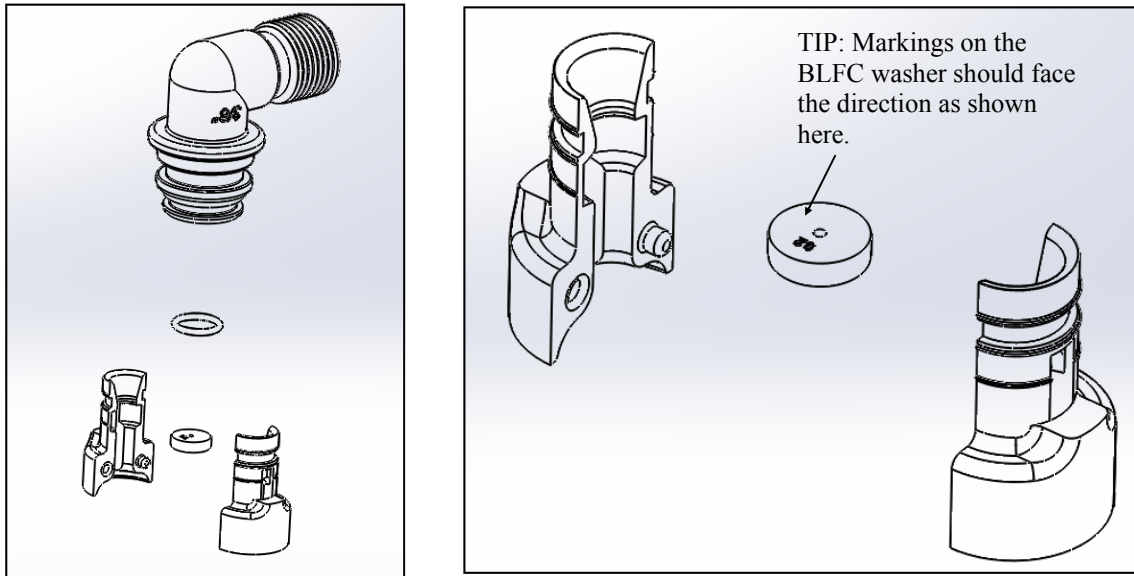

1. Remove the red clip that secures the brine elbow.
2. Remove the BLFC holder from the elbow fitting.
3. Split the BLFC holder apart and remove the flow washer.
4. Reassemble using the reverse procedure.

Replacing Drain Line Flow Control (DLFC)

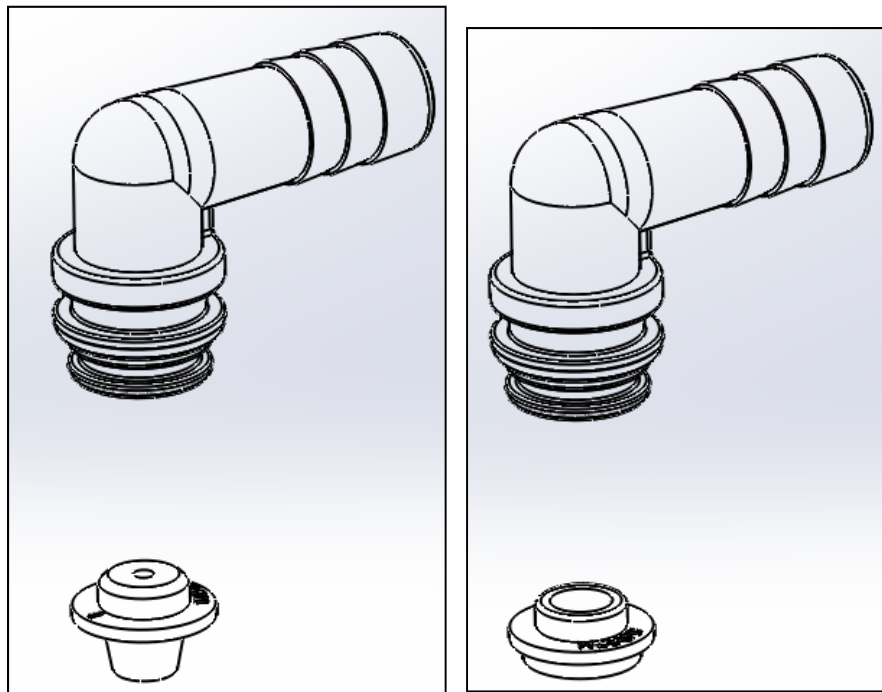

1. Remove the red clip that secures the drain line elbow.
2. Remove the BLFC washer from the elbow fitting.
3. Reassemble using the reverse procedure.

Care of Your System

To retain the attractive appearance of your new water Speciality System, clean occasionally with mild soap solution. Do not use abrasive cleaners, ammonia or solvents. Never subject your specialty system to freezing or to temperatures above 100°F.

Resin Cleaner

DO NOT USE any resin cleaners.

The use of resin cleaner can harm your specialty unit and void the warranty.

Control Valve Exploded View

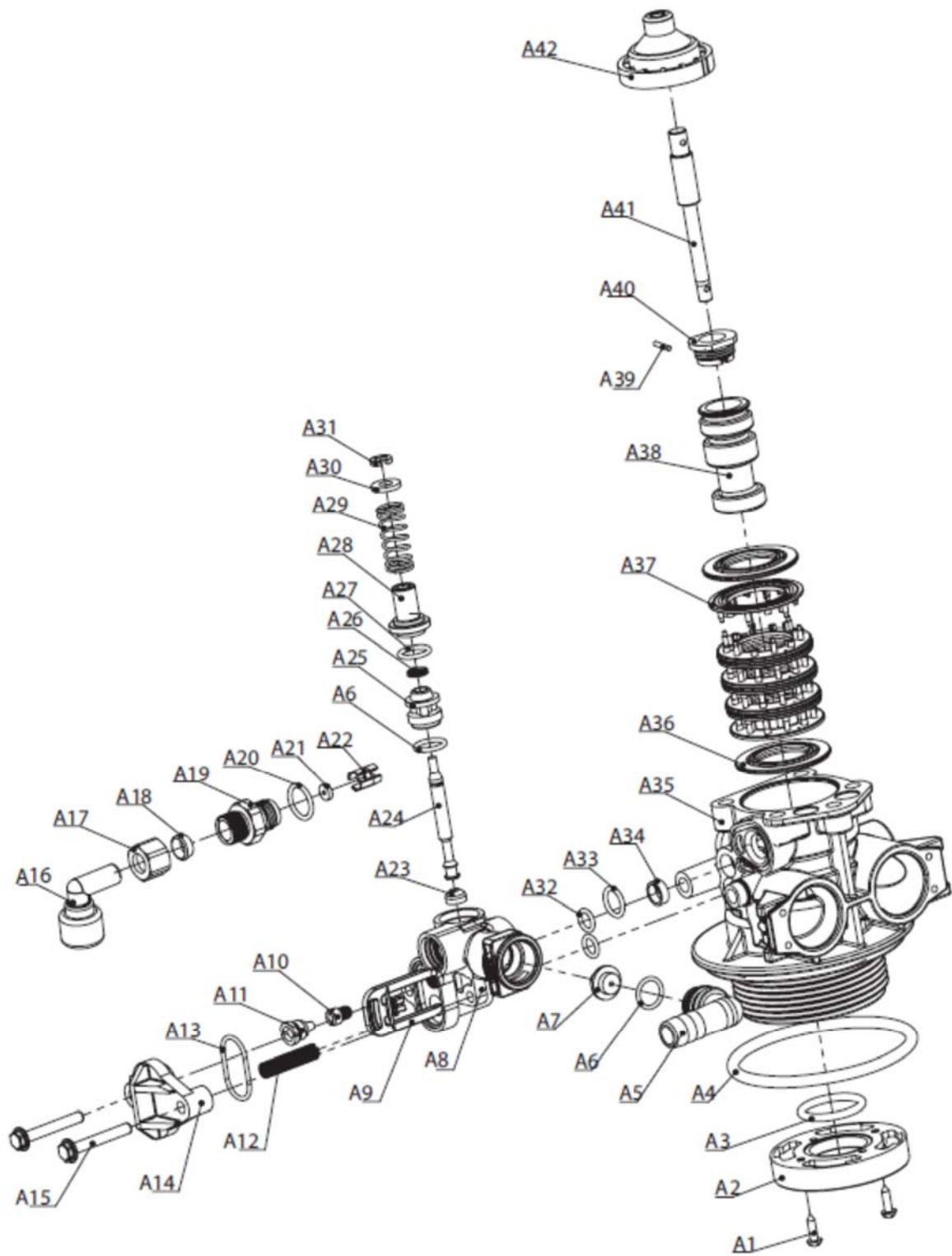

Control Valve Parts List

No.	Part # (WaterGroup)	Description	Qty
A42	13446	End Plug Assy	1
A41	60095604	BNT 75 Piston Rod	1
A40	60010646	Piston Retainer	1
A39	60010647	Pin	1
A38	60010648	Piston	1
A37	14241	Spacer	8
A36	13242-02	Seal	1
A35	60095609	BNT 75 Valve Body	1
A34	60010095	Air Dispenser	1
A33	60010096	O-ring(11×2)	1
A32	60010094	O-ring(7.8×1.9)	2
A31	60010028	Retainer Ring	1
A30		Injector Washer	1
A29		Injector Spring	1
A28		Injector Cap	1
A27		O-ring(12.5×1.8)	1
A26		Quad Ring	1
A25		Injector Spacer	1
A24		Injector Stem	1
A23		Injector Rubber Seat	1
A22		60010081	BLFC Button Retainer
A21	60010110	BLFC(0.3GPM)	1
A20	60010083	O-ring (14×1.8)	1
A19	13244	Copper Fitting	1
A18	60010087	BLFC Fernule	1
A17	60010088	BLFC FITTING NUT	1
A16	60010656	QC Brine Elbow	1
A15	60010089	SCREWS M5×30	2
A14	60010090	Injector Plug	1
A13	60010091	O-ring(23.9×1.8)	1
A12	60010192	Injector Screen	1
A11	60010033	Injector Nozzle(White)	1
A10		Injector Throat(White)	1
A9	60010069	Clips	1
A8	60010093	Injector Body	1
A7	60010657	DLFC 3.0GPM	1
A6	60010044	O-ring(12×2)	1
A5	60090001	QC Drain Line Elbow	1
A4	60010077	O-ring(78.74×5.33)	1
A3	60010080	O-ring(25×3.55)	1
A2	60010599	Valve Bottom Connector	1
A1	60010574	SCREWS ST3.5×13	2

Power Head Exploded View

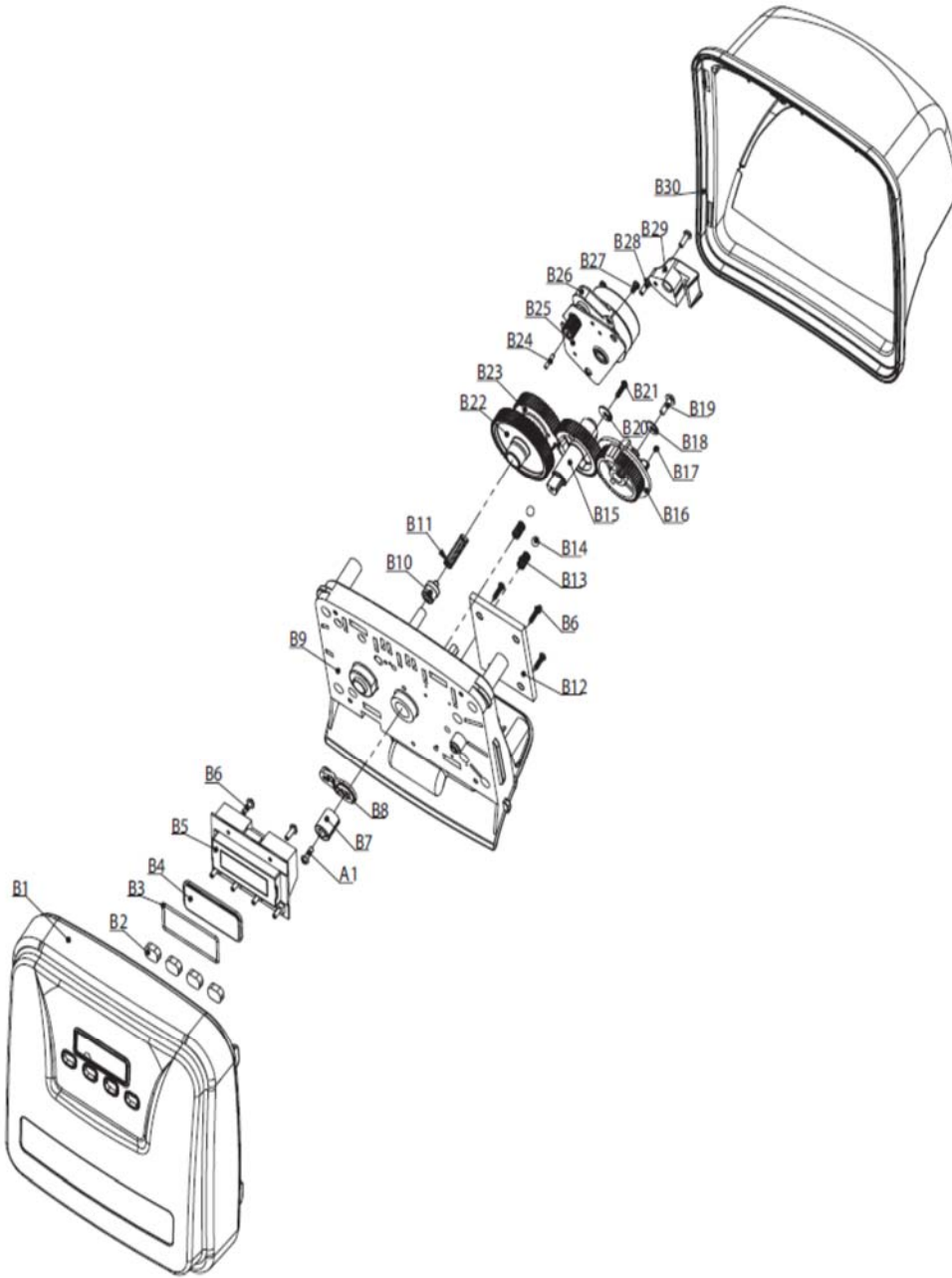

No.	Part # (Water group)	Description	Qty
B30	60095084	BNT365 Cover	1
B29	60010055	Piston Stem Holder	1
B28	60010054	Screw-ST3.5x13	2
B27	60010658	Screw-M3x5	2
B26	92393	Motor-12v/2rpm	1
B25	60010659	Motor Mounting Plate	1
B24	60010660	Motor Pin	1
B23	60010664	Bnt165 Drive Gear	1
B22	60010677	Idler Gear	1
B21	60010099	Screw-ST2.9x13(Large Wafer)	1
B20	60010100	Washer-3x13	1
B19	60010575	Screw-ST4.2x12(Large Wafer)	1
B18	60010661	Screw-ST4.2x12(Large Wafer)	1
B17	60010672	Magnet-φ3x2.7	1
B16	60010662	Brine Gear	1
B15	60010663	Main Gear	1
B14	60010667	Ball-1/4inch	2
B13	60010668	Spring Detent	2
B12	60010113	BNT85 Main PCB	1
B11	60010103	Spring Idler	1
B10	60010666	Spring Retainer	1
B9	60095085	BNT365 Base	1
B8	60010671	Magnet Holder	1
B7	60010059	Locking Knob	1
B6	60010673	Screw-ST2.9x10	8
B5	60010051	BNT 85 Main PCB	1
B4	60095086	Display Protective Cover	1
B3	60095612	O-ring 40x1.8	1
B2	60010615	BNT465 Button	4
B1	60010056	BNT565 Front Cover	1

Trouble Shooting

Issue	Possible Cause	Possible Solution
A. Unit fails to initiate a regeneration cycle.	1. No power supply.	Check electrical service, fuse, etc.
	2. Defective circuit board.	Replace faulty parts.
	3. Power failure.	Reset time of day.
	4. Defective meter.	Replace turbine meter.
B. Water is hard.	1. By-pass valve open.	Close by-pass valve.
	2. Out of salt or salt level below water level.	Add salt to tank.
	3. Plugged injector / screen.	Clean parts.
	4. Flow of water blocked to brine tank.	Check brine tank refill rate.
	5. Hard water in hot water tank.	Repeat flushing of hot water tank required.
	6. Leak between valve and central tube.	Check if central tube is cracked or o-ring is damaged. Replace faulty parts.
	7. Internal valve leak.	Replace valve seals, spacer, and piston assembly.
	8. Reserve capacity setting too low.	Increase reserve capacity.
	9. Not enough capacity.	Increase salt dosage.
C. Salt use is high.	1. Refill time is too high.	Check refill time setting.
	2. Defective flow control.	Replace.
D. Low water pressure.	1. Iron or scale build up in line feeding unit.	Clean pipes.
	2. Iron build up inside valve or tank.	Clean control and add resin cleaner to clean bed. Increase regeneration frequency.
	3. Inlet of control plugged due to foreign material.	Remove piston and clean control valve.
	4. Deteriorated resin. (Maybe caused from high chlorine or chloramines.)	Re-bed unit. Consider adding carbon pre-treatment.
E. Resin in drain line.	1. Air in water system.	Check well system for proper air eliminator control.
	2. Incorrect drain line flow control (DLFC) button.	Check for proper flow rate.
F. Too much water in brine tank.	1. Plugged injector or screen.	Clean parts.
	2. Valve not regenerating.	Replace circuit board, motor, or control.
	3. Foreign material in brine valve.	Clean parts.
	4. Unit not drawing brine.	Check for vacuum leak in brine line connections.
G. Unit fails to draw brine.	1. Drain line flow control is plugged.	Clean parts.
	2. Injector or screen is plugged.	Clean parts.
	3. Inlet pressure too low.	Increase pressure to 25 PSI.
	4. Internal valve leak.	Replace seals, spacers, and piston assembly.
	5. Safety valve closed.	Check for leak in brine line connections. Replace safety float assembly.
	6. Vacuum leak in brine line.	Check for leak in brine line connections. Tighten all connections.
	7. Drain line has kink in it or is blocked.	Check drain line.
H. Valve continuously cycles.	1. Defective position sensor PCB.	Replace faulty parts.
I. Flow to drain continuously.	1. Valve settings incorrect.	Check valve settings.
	2. Foreign material in control valve.	Clean control.
	3. Internal leak.	Replace seals, spacers, and piston assembly.
	4. Piston is stuck in position. Motor may have failed or gears have jammed or disengaged.	Check for power to motor. Check for loose wire. Check for jammed gears or gears disengaged. Replace faulty parts.
J. Valve makes beeping sound.	1. The piston has not advanced to the next cycle position properly.	Check for power to motor. Check for loose wire. Check for jammed gears or gears disengaged.

Warranty

Canature WaterGroup warrants that your new water conditioner is built of quality material and workmanship. When properly installed and maintained, it will give years of trouble free service.

Seven Year Complete Parts Guarantee

Canature WaterGroup will replace any part which fails within 84 months from date of manufacture, as indicated by the serial number, provided the failure is due to a defect in material or workmanship. The only exception shall be when proof of purchase or installation is provided and then the warranty period shall be from the date thereof.

Life Time Warranty on Mineral Tanks and Brine Tanks

Canature WaterGroup will provide a replacement mineral tank or brine tank to any original equipment purchaser in possession of a tank that fails provided that the water conditioner is at all times operated in accordance with specifications and not subject to freezing.

General Conditions

Damage to any part of this water conditioner or filter as a result of misuse, misapplication, neglect, alteration, accident, installation or operation contrary to our printed instructions, damage to ion exchange resin and seals caused by chlorine / chloramines in the water supply, or damage caused by any force of nature is not covered in this warranty. We will repair or replace defective parts if our warranty department determines it to be defective under the terms of this warranty. Canature WaterGroup assumes no responsibility for consequential damage, labour or expense incurred as a result of a defect or failure.

