

Classic Series INSTALLATION AND MAINTENANCE MANUAL

RELIABLE CHEMICAL FEED PUMPS SINCE 1957



OPERATING REQUIREMENTS

CAUTION: PLEASE READ PRIOR TO INSTALLATION



WARNING: Risk of electrical shock. This pump is supplied with a grounding conductor and grounding type of attached plug. To reduce risk of electrical shock, be certain that it is connected to a properly grounded grounding-type electrical receptacle. This pump is intended for indoor use. Suitable for outdoor use when installed with a Stenner rainroof.

NOTE: This metering pump and its components have been tested for use with the following chemicals: Sodium Hypochlorite (10-15% solution); Muriatic Acid (20-22 Baume, 31.5% Hcl); Soda Ash.

AVERTISSEMENT: Risque de choc électrique. Cette pompe est équipée d'une fiche de mise à terre. Pour réduire le risque de choc électrique, s'assurer que la fiche est bien raccordée à une prise de courant avec une connexion de mise à terre.

Cette pompe est prévue pour utilisation à l'intérieur.

NOTE: Cette a pompe de dosage et ses composants ont été testés pour utilisation avec les produits chimiques suivants; Hypochlorite de Sodium (solution de 10-15%); Acide Muriatique (20-22 Baume, 31.5% Hcl); Cendre de Soude.

DO

- **DO** check outlet with volt meter before connecting power cord. This can prevent motor burnout from over voltage.
- **DO** mount the metering pump in a dry location on wall to avoid any risk of washdowns allowing water in the openings of the motor.
- **DO** use a rain roof to prevent water or debris intrusion on outdoor applications and indoor industrial job sites.
- **DO** connect the metering pump to the same electrical circuit as the pool or well pump. This will stop metering pump operation and prevent overfeeding in the event of an electrical malfunction.
- **DO** install metering pump according to the installation instructions provided. Stenner metering pumps properly installed and maintained provide a limited amount of protection from siphoning. Dependent on state or local building codes and system piping configurations, auxiliary devices may be required.
- **DO** use the proper product to treat potable water. Chemicals should be approved or listed for use with potable water.

DO NOT

- **DO NOT** use thread seal tape or pliers on pump tube fittings.
- **DO NOT** apply any type of lubrication grease or oil to the pump tube assembly.
- **DO NOT** mount the metering pump vertically with the pump head pointing up because chemical damage will occur in the event of leakage or tube rupture.
- **DO NOT** install the unit directly over the solution container. Solution containers should be kept covered or closed. Chemical fumes can damage the metering pump.
- **DO NOT** mount the metering pump on any flammable surface.
- **DO NOT** mix chemicals in or fill the solution tank while the metering pump is running. Keep the suction line away from the bottom of the solution container to eliminate residue pickup and possible clogging.
- **DO NOT** operate the metering pump before the chemical is completely in solution. Follow the chemical manufacturer's instructions for mixing. Soda Ash must be kept agitated continuously with a mixer tank.
- **DO NOT** install the metering pump in a way that will allow a possible cross connection of a non-potable water source to a potable water source.

OPERATING REQUIREMENTS

PRE-INSTALLATION INSTRUCTIONS

1. Verify metering pump model and voltage requirements.
2. Unpack pump and all box contents. Separate contents to verify all items have been received.

Accessories included with each metering pump are based on pressure rating (25 or 100 psi) and suction/discharge tubing size (1/4", 3/8", 6mm).

25 psi unit includes:

- (3) Connecting Nuts (1/4" or 3/8")
- (3) Ferrules
- (1) Injection Fitting
- (1) Ceramic weight with clip
- (1) 20' roll of 1/4", 3/8" or 6mm suction & discharge tube (white or UV black)
- (1) Spare pump tube
- (1) Installation and Maintenance Manual

100 psi unit includes:

- (3) Connecting Nuts (1/4" or 3/8")
- (3) Ferrules
- (1) Injection Check Valve
- (1) Ceramic weight with clip
- (1) 20' roll of 1/4", 3/8" or 6mm suction & discharge tube (white or UV black)
- (1) Spare pump tube
- (1) Installation and Maintenance Manual

3. Read the Installation and Maintenance Manual before beginning the installation.

FOR YOUR RECORDS

MODEL # _____

SERIAL # _____

DATE OF INSTALLATION _____

PURCHASED FROM/INSTALLED BY _____

RECOMMENDED INSTALLATION SET UP _____

Disclaimer

The information in this manual is not intended for specific application purposes. G. H. Stenner & Co., Inc. reserves the right to make changes to prices, products and specifications at any time without prior notice.



Storage Suggestions

When your metering pump is not in use, we recommend that you:

- Run fresh water through pump to rinse chemical from pump tube and allow to run dry.
- Rinse off and wipe clean chemical residue or debris from tube housing & roller assembly to avoid corrosion.
- Store pump and pumping tubes in a non-corrosive environment and dry location to avoid possible water intrusion.
- Do not store pump tubes on chemical tank, in the pump room or direct sunlight.

PRODUCT SPECIFICATIONS

System output is determined by motor RPM and pump tube size, as well as by the setting of the feed rate control. In addition, Stenner chemical metering pumps are available as low-pressure or high-pressure models (0-25 psi=low pressure, 26-100 psi=high pressure).

Classic Series

U.S. Gallon Ranges:

Series 45.....	0.2-50 GPD
Series 85.....	0.3-85 GPD
Series 100.....	0.3-100 GPD
Series 170.....	0.5-170 GPD

Note: Max GPD for pressures 26-100 psi is 40 gallons. Contact factory for details.

Metric Ranges:

Series 45.....	0.6-151.4 LPD
Series 85.....	0.9-257.4 LPD
Series 100.....	0.9-302.8 LPD
Series 170.....	1.5-514.8 LPD

Note: Max LPD for pressures 1.72 bar to 5.9 bar is 121.1 liters per day. Contact factory for details.

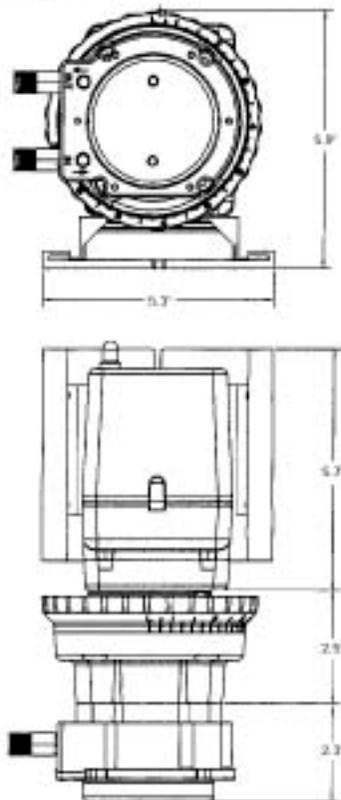

For double head adjustable models, add additional pump head (dimensions).
For dual head/dual control, add additional feed rate control & pump head (dimensions).

Specifications:

Discharge Pressures	0-100 psi; 0-6.9 bar
Output Ranges	0.2-170 gallons/day; 0.6-514.8 liters/day
Turndown Ratio	(adjustable models) 20:1, 5% to 100% in 2.5% increments
Voltages Available	120v 60 Hz; 220v 60 Hz; 230v 50 Hz; 250v 50Hz
Motor RPM	26 (45 & 100 series); 44 (85 & 170 series)
Amp Draw	1.70 120v; 0.9 220v, 230v, 250v
Horsepower	1/30 fractional
Connections	1/4", 3/8" or 6mm suction/discharge tubing
Shipping Weight	6 lbs (2.72 kg)-single head, fixed 8 lbs (3.63 kg)-single head adjustable 8.5 lbs (3.85 kg)-double head, fixed 9 lbs (4.08 kg)-double head, adjustable 10 lbs (4.53 kg)-dual head/dual control
Viscosity	Maximum 1500 cps; over 1500 cps consult factory
Operating Temperature ...	Maximum 125 degrees Fahrenheit/ 51.6 degrees Celsius

Materials of Construction:

All Housings*..... Lexan® Polycarbonate Plastic

Peristaltic Tube**..... Santoprene® FDA Approved

Check Valve Duckbill

Suction/Discharge Tubing... LDPE Polyethylene-NSF/FDA Approved
Ferrules(1/4" & 6mm)

Tube Fittings..... Type 1 Rigid PVC-NSF Listed

Connecting Nuts

Check Valve Fittings

Ceramic Weight Clip

Suction Weight..... Ceramic

All Fasteners..... Stainless Steel

* Lexan® is a registered trademark of General Electric. Consult General Electric for chemical resistance of Lexan®.

**Santoprene® is a registered trademark of Advanced Elastomer System. Refer to chemical resistance chart in Stenner catalog for material compatibility.

Materials for all wetted parts have been tested and approved for potable water applications.

INSTALLATION INSTRUCTIONS

All metering pumps are portable and are designed to be readily removable from the plumbing system without damage to connections. They are removable from the building structure without tools.

Discharge Side

Shut off water supply.

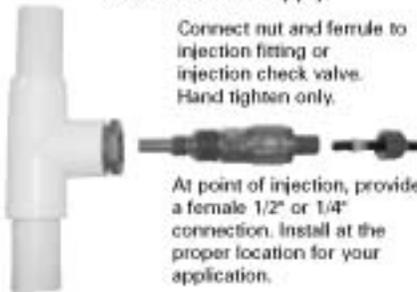

Connect nut and ferrule to injection fitting or injection check valve. Hand tighten only.

At point of injection, provide a female 1/2" or 1/4" connection. Install at the proper location for your application.



Note: The use of an injection check valve as shown above is required in all high-pressure applications (26 to 100 psi - 1.73 to 6.9 bar).

To prevent leaks, all the ferrules must be installed as illustrated.

Cut suction/discharge tubing to desired length with enough slack to avoid kinks.

Connect nut, ferrule and discharge tubing to the discharge side of the pump head (labeled "out" on cover of head). Finger tight only. Do not use thread seal tape.

Connect nut, ferrule and suction tubing to the suction side of the pump head (labeled "in" on cover of head). Hand tighten only. Do not use thread seal tape.

Suction Side

Run the suction tubing to the solution tank. Allow for some slack in the tube to avoid kinks.

Measure the suction tubing on outside of solution tank to ensure it will be 2-3" from the bottom of the tank. Do not allow weight to sit at the bottom of the tank.



Immerse in Solution Tank.

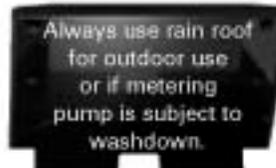

Plugging In

Check voltage of the outlet vs. voltage requirement of metering pump with a voltage meter.

Turn pump on and set feed rate dial to desired GPD. Refer to the output chart of your specific model number.

Plug into a grounded power source.



Optional Spill Recovery

Detach cover. Punch out one of the indented holes with a 7/32" punch.



Insert a length of 1/4" suction/discharge tubing into the newly created hole and place the other end back into the solution tank.

Chemicals will drain back into solution tank reducing spillage.

Correct Mounting Position

STEP 1

Mount Chemical Metering Pump and Verify Voltage Supply

1.1 Locate a suitable location within ten feet of the point of injection. Preferably one to two feet above highest level of chemical solution tank. **DO NOT** mount pump directly over chemical solution tank. **AVOID** flooded suction installations. Example: A bulk fitting or bung fitting at the bottom or side of tank.

1.2 Using the wall-mounting bracket provided, mark the location of the screw pilot holes by using the bracket as a template. Drill pilot holes as required.

Note: Allow eight inches of clear space above or behind the mounting bracket for pump installation/removal. This allows the ability to invert pump in the bracket during pump tube replacement.

1.3 Secure the wall-mounting bracket to the chosen location with a suitable fastener/anchor combination.

Note: The mounting bracket allows the motor base to slide into the bracket from one direction only. Visually verify that the orientation of the bracket will allow the motor base to slide into the mounting bracket from above (vertical mount-recommended) or behind (horizontal mount-optional).

INSTALLATION INSTRUCTIONS

STEP 1...CONTINUED

- 1.4 Slide the feeder into the bracket from the top.
- 1.5 Ensure the feeder's motor On-Off switch is in the **OFF** position. Before plugging in the pump, verify the voltage of the control circuit receptacle using a voltmeter or multi-meter. Cycle the pump control (flow switch, pressure switch, etc.) to verify the metering pump power supply circuit works in conjunction with the control equipment.
- 1.6 Plug the power cord into the receptacle. Stenner pumps are to be plugged into a properly installed grounding-type electrical receptacle. Installation should adhere to national and local codes. Consult a licensed professional for assistance as required.
- 1.7 Turn the Feed Rate Control dial to setting "10". Cycle motor On-Off switch to **ON**. Observe the rollers turn continuously.
- 1.8 Turn switch to **OFF** position. Proceed to Step 2.

STEP 2

Install Suction Line

- 2.1 Locate the 20' roll of suction/discharge tubing and uncoil. Determine the required amount of suction tubing required to reach two to three inches from the bottom of chemical tank. Use the outside of the tank as a guide. Mark this length on tubing.
- 2.2 Using a sharp utility knife, cut the tubing square and burr free.
- 2.3 Slide the connecting nut over the tubing, followed by the ferrule. Slide up the tube 1/2" to 3/4", making sure the tapered or angled portion of the ferrule and the female thread end of the nut is pointed towards the cut end of tubing.
- 2.4 Insert the tubing approximately 3/4" into pump tube discharge fitting labeled "IN" on tube housing cover. **FINGER TIGHT ONLY** while holding the "IN" fitting to prevent rotation.
- 2.5 Drill a 17/64" hole into the bung cap, lid bottle cap, etc., of the chemical tank. Push the suction tubing into the tank.

STEP 2...CONTINUED

- 2.6 Insert the tubing into the ceramic weight assembly keeping the tubing approximately one inch from the end of the ceramic weight. Suspend the ceramic weight two or three inches above the bottom of tank. Proceed to Step 3.

Note: **DO NOT** install suction/discharge tubing with tight radius bends or without slack. Insufficient slack or tight bends will cause excessive stress to the tubing leading to stress cracks and failure.

STEP 3

Install Discharge Line

- 3.1 Locate remaining suction/discharge tubing, two connecting nuts and ferrules.
- 3.2 Repeat step 2.3. Install connecting nut and ferrule 1/2" to 3/4" up the tubing.
- 3.3 Insert the tubing approximately 3/4" into pump tube discharge fitting labeled "OUT" on tube housing cover. **FINGER TIGHT ONLY** while holding the "OUT" fitting to prevent rotation.
- 3.4 Shut off water or circulation system and bleed off any resident system pressure.

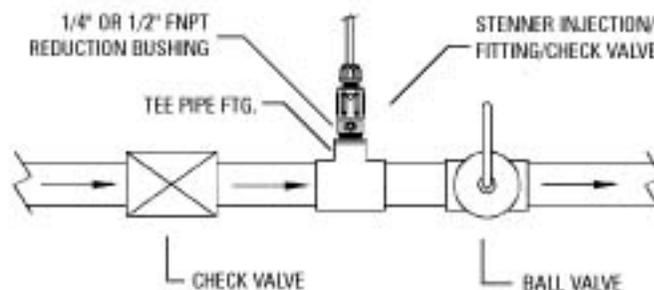

- 3.5 Locate suitable point of injection. Install beyond all pumps and filters or as determined by application. If there is no 1/2" or 1/4" NPT female fitting at the location, one will have to be provided. (refer to Steps 3.6 or 3.7)
- 3.6 Drill and tap the pipe wall 1/2" or 1/4" FNPT.

STEP 3...CONTINUED

- 3.61** Drill the proper tap-size hole directly into the pipe wall (if a hole exists from previous install, be sure it is cleared of any build up). Use caution when drilling so as not to drill completely through pipe.
- 3.62** Using a corresponding size pipe tap, run the tap into hole 3 to 4 full threads of the tap. DO NOT run the tap too far into the hole. Go slowly and use the MNPT end of the injection fitting or check valve as a gauge to check thread fit.

Helpful Tip: Verify thread fit with the FNPT end of the injection fitting. Proper FNPT thread engagements allow for two-and-a-half to three turns of the male thread or nipple before full engagement.

- 3.7** Install a suitable pipe tee fitting or reduction tee. Use the proper procedures for solvent welding PVC fittings as provided by the glue manufacturer. Allow ample drying time as recommended by the manufacturers instructions for the product being used.
- 3.8** Locate the injection fitting or injection check valve. Wrap the MNPT end of the fitting with 2 to 3 wraps of thread seal tape.
- 3.9** Install the MNPT end of the fitting into the FNPT point of injection and hand tighten. Trim extension tip as required to put tip directly in the flow of water.

STEP 3...CONTINUED

- 3.10 High pressure install (26-100 psi models)**
Turn on the water system and allow the system to reach operating pressure. Check the installed check valve for leaks at the NPT threads and tighten an additional 1/4 to one turn if required. Install the remaining connecting nut and ferrule onto the discharge tubing. Insert the tubing into the injection check valve until tubing bottoms in the fitting. Tighten the connecting nut.

Low pressure install (0-25 psi models)
Install the remaining connecting nut and ferrule onto the discharge tubing. Insert the discharge tubing into the injection fitting 3/4" to 1". Tighten the connecting nut.

- 3.11** Turn the metering pump ON.
- 3.12** Allow the metering pump to run on setting "10" to prime system. Visually observe the chemical move through the tubing (when tubing is clear).
- 3.13** Turn the Feed Rate Control Dial to your required initial setting. Check the entire system for leaks.
- 3.14** After a suitable amount of time dosing, verify your application with test equipment. Perform final adjustments to the metering pump setting to provide the required residual or results as determined through adequate test equipment or analysis.

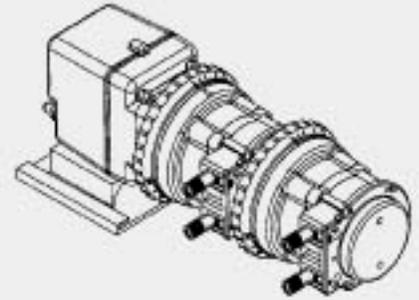

Determining Dual Head Dual Control Output

On double-head systems, dual-control mechanisms are available to match your application needs. In this type of configuration, the outside head is set to operate at a percentage of the inside head. To determine output rates on a dual head dual control pump:

1. Use the appropriate output table to select the desired output for the inside pump head, or Primary Output.

2. Using as an example:
170MDC5

- Primary feed rate control on 4 = 34 GPD (103 LPD)
- Outside feed rate control on 3 = 30% of primary feed rate setting OR 10.2 GPD (30.9 LPD)

Note: The outside feed rate control is completely dependent on the primary feed rate control. To achieve maximum output both settings have to be on 10.

PUMP TUBE REPLACEMENT INSTRUCTIONS

Removing the Old Pump Tube

1. Turn metering pump "off."
2. Unscrew and remove the tube housing cover.
3. Set the Feed Rate Dial to L setting and leave on this setting until finished.
4. Turn the pump "on" and let it run until one of the three slots in the roller assembly lines up with the bottom tube fitting (suction side).
5. Turn pump "off."
6. Without moving the roller assembly further, lift the tube fitting out of the housing slot and pull it toward the center of the roller.
7. Turn the pump "on" and allow roller assembly to jog while guiding the tube up and out of the housing. Turn the pump "off" when the slot in the roller assembly aligns with the "OUT" (discharge) tube fitting. Completely remove the tube assembly.

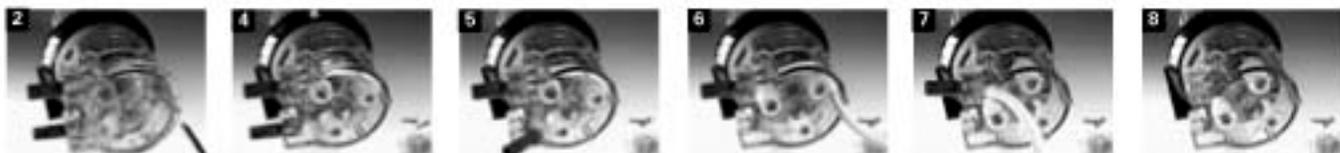

Installing the New Pump Tube

1. With the pump still on L setting, run until one of the three slots in the roller assembly lines up with the bottom tube fitting (suction side). Turn pump "off."
2. Place the tube fitting into position in the housing and slot.
3. Turn the pump "on" and allow the pump to jog the roller assembly while guiding the tube to prevent it from getting pinched between housing and roller assembly.
4. When the roller assembly slot reaches the housing slot the fitting inserts into, turn pump "off." Turn Feed Rate Dial to "10." While holding fitting away from roller assembly, turn pump "on" and allow rollers to stretch tube until fitting can be inserted into the housing.
5. Turn the pump "off."
6. Replace the cover and the screws leaving the front screws over the fitting loose enough to rotate the tube fitting.



Centering the Pump Tube

To obtain maximum tube life, the tube must ride in the center of the rollers.

1. To center the tube on the rollers, set the Feed Rate Dial to setting "10." Turn pump "on."
2. Turn the "IN" (suction) tube fitting located on the bottom of the pump head not more than 1/8" of a turn in the direction in which the tube must move.
3. Observe the tube assembly respond and adjust in either direction until the tube rides approximately in the center of the rollers.
4. Turn the pump "off." Tighten the cover screws.



Note: Avoid rotating your wrist while installing tube. This will prevent tube twisting. A twisted tube will not center. **BE CAREFUL OF YOUR FINGERS.** Do not force the tube.

IMPORTANT TIP

Schedule a Regular Pump Tube Maintenance Change to prevent chemical damage to pump and/or chemical spillage

- Always rinse off and wipe chemicals, residue and debris from the pump head components before replacing the tube.
- Check the pump tube regularly for leaks and wear. At the first sign of leakage, replace the pumping tube and ferrules.
- Inspect the suction/discharge tubing, injection point (into the pipe) and injection check valve duckbill for blockages after any tube rupture. Clear as required.
- Inspect the pump head components for cracks. Ensure that the rollers are spinning freely.
- Tighten the suction/discharge connecting nuts, finger tight only.
- Pump fresh water through the tubing to clean out chemicals if the unit is to be shut off for a prolonged period or shipped.
- Follow all the guidelines for pump tube installation and centering.

IMPORTANT CAUTIONS

- Use caution when disconnecting the suction/discharge lines when changing the tube or the tube housing as they may contain hazardous chemicals. Loosen connection nut to relieve resident pressure on the discharge "OUT" pump tube.
- Always wear proper protective safety equipment, such as gloves, apron, safety glasses, face shield, etc., when performing maintenance on chemical metering pumps.

SEPARATING AND RECONNECTING COMPONENTS

Stenner's quick-lock riveting system makes component separation and reconnection fast and easy.



Pump Head Removal

1. Turn "off" the pump and unplug the power cord.
2. Hold the pump motor section and turn the pump head clockwise, until it stops.
3. Pull the pump head straight out and off.

Note: Older fixed-output pumps that have had a tube rupture may require the use of a flat blade screwdriver to assist in pump head removal. Insert the screwdriver behind the pump head and carefully pry the pump head off the motor shaft while pulling.

Pump Head Installation

1. Hold the pump motor section and insert the motor shaft into the pump head making sure the flat of the motor shaft aligns with the corresponding flat of roller assembly.
2. Rotate the pump head until the locking rivets on the front of the pump motor align with the corresponding mounting locations of the pump head.
3. Push the head onto the motor shaft until it bottoms.
4. Turn counterclockwise to engage mounting rivets.

CLEANING THE POINT OF INJECTION

Periodic inspection and cleaning of the point of injection will maintain proper pump operation and provide maximum pump tube life.

Note: Low-pressure models are installed using an injection fitting and high-pressure models use an injection check valve. Both allow the extension tip to be installed in the center of the pipe directly in the flow of water to help reduce deposit accumulation.

CAUTION:

- Always wear proper protective safety equipment, such as gloves, apron, safety glasses, face shield, etc., when performing maintenance on chemical metering pumps.
 - Always disconnect all electrical connections and remove or bleed off resident system pressure in the lines and pump before performing any maintenance or repair.
1. Turn metering pump "off" and unplug power cord. Disable water pump or auxiliary equipment electrical supply.
 2. Depressurize system and bleed pressure from pump discharge tubing.
 3. Loosen and remove connecting nut and ferrule from the injection check valve or injection fitting to disconnect discharge tubing.

For high-pressure models (100 psi)

- Unscrew the top fitting (check valve body) to disassemble. The bottom fitting (injection fitting with arrow) should remain attached to the pipe.
 - Remove duckbill from check valve body and replace if deteriorated or swollen (yearly replacement recommended). If clogged, clean or replace.
 - Examine O-Ring on the injection fitting and replace if deteriorated or damaged.
4. Insert a round shank screwdriver through injection fitting into the pipe to locate or break up accumulated deposits. If screwdriver cannot be inserted, drill the deposit out of the injection fitting. (Do not drill through the opposite pipe wall.)
 5. Replace discharge tubing if cracked or deteriorated. If the end is clogged, cut off the calcified or blocked section of tubing.

6. For low-pressure models (25 psi)

- Replace ferrule and insert the discharge tubing into the injection fitting approximately 3/4"-1" until it stops.

For high-pressure models (100 psi)

- Reassemble the injection check valve in reverse order.
 - Replace ferrule and insert the discharge tubing into the injection check valve approximately 3/4" until it stops.
7. Tighten the connecting nut finger tight.
 8. Enable the water pump electrical supply and pressurize the water system.
 9. Put the metering pump back in service and inspect all connections for leaks.

TROUBLESHOOTING GUIDE

PROBLEM	POSSIBLE CAUSE	SOLUTION
Motor		
IMPORTANT: DISCONNECT POWER CORD BEFORE SERVICE OR COVER REMOVAL.		
Motor bearings are loud.	Worn ball bearings.	The ball bearings should spin freely. Worn bearings could cause a locked rotor. Replace rotor assembly as required.
Motor runs, pumping head does not.	Gear is stripped.	Check phenolic gear or output shaft with gear. If replacing gears, regrease.
Feed Rate Control		
Dial won't turn or respond to setting change.	Variable cam might be broken or chemically damaged. 90-degree bend has pulled out of the dial ring.	Replace variable cam as required. Reinsert the 90-degree bend into dial ring boss (hole).
	Index pin is stuck up – pump head not turning. Index pin is stuck down – no response to adjustment.	Clean the index pin and holder of any debris. Regrease index pin and index pin spring with Stenner Grease. If index spring is corroded, replace.
Dragging or ratcheting sound is present.	Variable cam and/or lifter worn.	Replace variable cam following directions on the back of the package. Replace index pin lifter.
	Holes in index plate are elongated from wear.	Flip index plate to other side or replace if both sides have been used.
		Note: Before reassembling, always use Stenner Grease to lubricate the output shaft (on motor), the main shaft (before inserting into roller assembly), the brass spider (on bottom of spider, before placing on top of index plate), and the index pin and spring.
Pump Tube		
Important: A leaking tube damages the pump. Inspect the pump frequently for leakage and wear, and to be sure the tube is properly centered. Before replacing the tube, always thoroughly rinse out the tube housing and roller assembly to remove chemical residue.		
Pump tube is leaking.	Pump tube might be worn or ruptured.	Replace the pump tube following the directions on the back of the package and in the Installation & Maintenance Manual. Ferrules must be used in connections and changed every time a pump tube is changed.
	Pump tube not centered and rubs against roller assembly.	Replace pump tube (see instructions for Installing and Centering). Do not use tools.
	Pump tube ruptures because back pressure and exceeds psi rating.	Replace pump tube. Check injection point, check valve duckbill and suction/discharge tubing for blockage. If particulate pickup is a problem, use of strainer is recommended. Clean or replace duckbill at each tube change. Clean point of injection. Refer to page 9.
Pump Head & Connections		
Lack of output.	Empty solution tank.	Stenner pumps can run dry; fill solution tank and pump will resume pumping.
	Suction line above chemical line.	Use ceramic weight with clip (included in accessory kit) to prevent suction line from floating to the top of the solution tank. Be sure suction line is 2-3" above the bottom of the tank.
	Cracks are present.	Any cracks in the pump head will deter proper pumping. Replace pump tube and any cracked component of pump head: roller assembly, housing or cover.
	Clogged injection point, suction/discharge tubing or injection check valve.	Clean and replace as necessary following procedure provided on page 9.
	Injection point is in the wrong location.	Injection point should be located as determined by application.
	Worn or ruptured pump tube.	Replace and properly center pump tube.

ROTOR AND CAM ASSEMBLY REPLACEMENT INSTRUCTIONS

Rotor Assembly



CAM Assembly



Rotor Assembly Replacement Instructions

1. Remove the two motor cover screws with Phillips screwdriver. Remove motor cover to expose motor fan, rotor and coil assembly.
2. Pry off plastic fan with flat head screwdriver.
3. With Phillips screwdriver, remove the two coil screws and lock washers (set aside), then remove and discard the first plastic bearing bracket.
4. Take the coil out of the motor housing and set aside.
5. Remove the rotor assembly, second plastic bearing bracket and discard both.
6. Snap new plastic bearing bracket with tolerance ring into place.
7. Install new rotor assembly. Be sure the helical gear end of the shaft is inserted into the gearcase.
8. Reinstall the coil over the rotor. When viewing from the fan end of the rotor shaft, the copper shaded pole on the coil is to the right.
9. Place the second plastic bearing bracket with tolerance ring through the rotor shaft and snap into place.
10. Reinstall the two coil screws and lock washers. Be sure to turn the self-tapping screws backwards, until they fall into the original threads of the motor housing to avoid stripping.
11. Tighten the coil screws down and press the fan (hub side down) back onto the rotor shaft.
12. Reassemble motor cover. Turn screws counterclockwise to engage threads. Once engaged in threads, tighten screws clockwise.

CAM Replacement Instructions

1. Grasp the feed rate control, turn clockwise and pull away to detach from the motor.
2. Remove the three mounting plate screws and the mounting plate.
3. Remove the feed rate dial and observe how the old cam is installed before removing it.
4. Remove old cam from guide slot.
5. Before installing the new cam, lubricate the angled tip with grease from the feed rate control.
6. Feed the angled tip into the slot while making sure that the 90-degree bent end is pointing in the correct direction (see above illustration). To keep the cam from rising up while inserting, place finger as a guide over the cam guide slot. Feed entire cam in until the angled tip is approximately 1/2" from contacting cam. Place the spider on the index plate so the lifter is in the 1/2" cam gap and the pin tip is in a hole in the index plate.
7. Insert the 90-degree bent end of the cam into the dial ring boss (hole) and fit the dial ring on the feed rate housing.
8. Put the mounting plate back on the feed rate, aligning the arrows located on the mounting plate and feed rate housing.
9. When replacing the mounting plate screws, start by turning the screws counterclockwise to engage the existing threads. Once properly engaged in threads, turn the screws clockwise.
10. Grasp the dial ring in one hand and the feed rate housing with the other hand with the arrow facing up. Turn the dial ring from L to 10 and back again. dial ring should move easily, without binding.

OUTPUT SPECIFICATIONS

Series 45 M – Adjustable Low Pressure: 0 to 25 psi (1.72 bar) Maximum Discharge Pressure

MODEL TUBE FEED RATE CONTROL SETTING: Outputs per day in U.S. Gallons @ 60Hz (left) & Liters @ 50Hz (right)

		L	1	2	3	4	5	6	7	8	9	10
45M1	#1	0.2	0.6	0.9	1.2	1.5	1.8	2.1	2.4	2.7	3.0	3.3
45M2	#2	0.5	1.5	2.0	2.7	3.4	4.1	4.8	5.5	6.2	6.9	7.6
45M3	#3	1.1	3.3	4.4	6.0	8.0	10.0	12.0	14.0	16.0	18.0	20.0
45M4	#4	1.7	5.1	6.8	9.1	12.1	15.1	18.1	21.1	24.1	27.1	30.1
45M5	#5	2.5	7.6	10.1	13.4	17.1	20.8	24.5	28.2	31.9	35.6	39.3

Series 45 MHP – Adjustable High Pressure: 0 to 100 psi (6.9 bar) Maximum Discharge Pressure

MODEL TUBE FEED RATE CONTROL SETTING: Outputs per day in U.S. Gallons @ 60Hz (left) & Liters @ 50Hz (right)

		L	1	2	3	4	5	6	7	8	9	10
45MHP2	#1	0.2	0.6	0.9	1.2	1.5	1.8	2.1	2.4	2.7	3.0	3.3
45MHP10	#2	0.5	1.5	2.0	2.7	3.4	4.1	4.8	5.5	6.2	6.9	7.6
45MHP22	#7	1.1	3.3	4.4	6.0	8.0	10.0	12.0	14.0	16.0	18.0	20.0

Series 85 M – Adjustable Low Pressure: 0 to 25 psi (1.72 bar) Maximum Discharge Pressure

MODEL TUBE FEED RATE CONTROL SETTING: Outputs per day in U.S. Gallons @ 60Hz (left) & Liters @ 50Hz (right)

		L	1	2	3	4	5	6	7	8	9	10
85M1	#1	0.3	0.9	1.2	1.5	1.8	2.1	2.4	2.7	3.0	3.3	3.6
85M2	#2	0.8	2.4	3.2	4.0	4.8	5.6	6.4	7.2	8.0	8.8	9.6
85M3	#3	2.0	6.1	8.0	10.0	12.0	14.0	16.0	18.0	20.0	22.0	24.0
85M4	#4	3.0	9.1	12.1	15.1	18.1	21.1	24.1	27.1	30.1	33.1	36.1
85M5	#5	4.3	13.0	17.3	21.6	25.9	30.2	34.5	38.8	43.1	47.4	51.7

Series 85 MHP – Adjustable High Pressure: 0 to 100 psi (6.9 bar) Maximum Discharge Pressure

MODEL TUBE FEED RATE CONTROL SETTING: Outputs per day in U.S. Gallons @ 60Hz (left) & Liters @ 50Hz (right)

		L	1	2	3	4	5	6	7	8	9	10
85MHP5	#1	0.3	0.9	1.2	1.5	1.8	2.1	2.4	2.7	3.0	3.3	3.6
85MHP17	#2	0.8	2.4	3.2	4.0	4.8	5.6	6.4	7.2	8.0	8.8	9.6
85MHP40	#7	2.0	6.1	8.0	10.0	12.0	14.0	16.0	18.0	20.0	22.0	24.0

Series 100 DM – Adjustable Low Pressure: 0 to 25 psi (1.72 bar) Maximum Discharge Pressure

MODEL TUBE FEED RATE CONTROL SETTING: Outputs per day in U.S. Gallons @ 60Hz (left) & Liters @ 50Hz (right)

		L	1	2	3	4	5	6	7	8	9	10
100DM1	#1	0.3	0.9	1.2	1.5	1.8	2.1	2.4	2.7	3.0	3.3	3.6
100DM2	#2	1.0	3.0	4.0	5.0	6.0	7.0	8.0	9.0	10.0	11.0	12.0
100DM3	#3	2.2	6.7	8.9	11.1	13.3	15.6	17.8	20.0	22.2	24.4	26.6
100DM4	#4	3.5	10.6	14.1	17.6	21.1	24.6	28.1	31.6	35.1	38.6	42.1
100DM5	#5	5.0	15.1	20.1	25.1	30.1	35.1	40.1	45.1	50.1	55.1	60.1

Series 100 DMHP – Adjustable Low Pressure: 0 to 100 psi (6.9 bar) Maximum Discharge Pressure

MODEL TUBE FEED RATE CONTROL SETTING: Outputs per day in U.S. Gallons (left) & Liters @ 50Hz (right)

		L	1	2	3	4	5	6	7	8	9	10
100DMHP5	#1	0.3	0.9	1.2	1.5	1.8	2.1	2.4	2.7	3.0	3.3	3.6
100DMHP20	#2	1.0	3.0	4.0	5.0	6.0	7.0	8.0	9.0	10.0	11.0	12.0

OUTPUT SPECIFICATIONS

Series 100 MDC – Adjustable Low Pressure: 0 to 25 psi (1.72 bar) Maximum Discharge Pressure

MODEL TUBE FEED RATE CONTROL SETTING: Outputs per day in U.S. Gallons @ 60Hz (left) & Liters @ 50Hz (right) for primary feed rate only

MODEL	TUBE	L		1		2		3		4		5		6		7		8		9		10	
100MDC1	#1	0.2	0.6	0.3	0.9	0.6	1.8	0.9	2.7	1.2	3.6	1.5	4.5	1.8	5.5	2.1	6.4	2.4	7.3	2.7	8.2	3.0	9.1
100MDC2	#2	0.5	1.5	1.0	3.0	2.0	6.1	3.0	9.1	4.0	12.1	5.0	15.1	6.0	18.2	7.0	21.2	8.0	24.2	9.0	27.3	10.0	30.5
100MDC3	#3	1.1	3.3	2.2	6.6	4.4	13.3	6.6	20.0	8.8	26.6	11.0	33.3	13.2	40.0	15.4	46.6	17.6	53.3	19.8	60.0	22.0	66.6
100MDC4	#4	1.7	5.1	3.5	10.6	7.0	21.2	10.5	31.8	14.0	42.4	17.5	53.0	21.0	63.6	24.5	74.2	28.0	84.8	31.5	95.4	5.0	106.0
100MDC5	#5	2.5	7.6	5.0	15.1	10.0	30.3	15.0	45.4	20.0	60.6	25.0	75.7	30.0	90.9	35.0	106.0	40.0	121.1	45.0	136.3	50.0	151.4

Series 100 MDCHP – Adjustable High Pressure: 0 to 100 psi (6.9 bar) Maximum Discharge Pressure

MODEL TUBE FEED RATE CONTROL SETTING: Outputs per day in U.S. Gallons @ 60Hz (left) & Liters @ 50Hz (right) for primary feed rate only

MODEL	TUBE	L		1		2		3		4		5		6		7		8		9		10	
100MDCHP5	#1	0.2	0.6	0.3	0.9	0.6	1.8	0.9	2.7	1.2	3.6	1.5	4.5	1.8	5.5	2.1	6.4	2.4	7.3	2.7	8.2	3.0	9.1
100MDCHP20	#2	0.5	1.5	1.0	3.0	2.0	6.1	3.0	9.1	4.0	12.1	5.0	15.1	6.0	18.2	7.0	21.2	8.0	24.3	9.0	27.3	10.0	30.3

Series 170 DM – Adjustable Low Pressure: 0 to 25 psi (1.72 bar) Maximum Discharge Pressure

MODEL TUBE FEED RATE CONTROL SETTING: Outputs per day in U.S. Gallons @ 60 Hz (left) & Liters @ 50Hz (right)

MODEL	TUBE	L		1		2		3		4		5		6		7		8		9		10	
170DM1	#1	0.5	1.5	1.0	3.0	2.0	6.1	3.0	9.1	4.0	12.1	5.0	15.1	6.0	18.2	7.0	21.2	8.0	24.2	9.0	27.3	10.0	30.3
170DM2	#2	1.7	5.1	3.4	10.3	6.0	18.2	9.5	28.8	13.6	39.1	17.0	51.5	20.4	61.8	23.8	72.1	27.2	82.4	30.6	92.7	34.0	102.6
170DM3	#3	4.0	12.1	8.0	24.2	16.0	48.5	24.0	72.7	32.0	96.9	40.0	121.1	48.0	145.4	56.0	169.8	64.0	193.6	72.0	218.0	80.0	242.2
170DM4	#4	6.0	18.2	12.0	36.3	24.0	72.7	36.0	109.0	48.0	145.3	60.0	181.7	72.0	218.0	84.0	254.4	96.0	290.7	108.0	327.0	120.0	363.4
170DM5	#5	8.5	25.7	17.0	51.5	34.0	86.0	51.0	154.4	68.0	205.9	85.0	257.4	102.0	308.9	119.0	360.4	136.0	411.8	153.0	463.3	170.0	514.8

Series 170 DMHP – Adjustable High Pressure: 0 to 100 psi (6.9 bar) Maximum Discharge Pressure

MODEL TUBE FEED RATE CONTROL SETTING: Outputs per day in U.S. Gallons @ 60 Hz (left) & Liters @ 50Hz (right)

MODEL	TUBE	L		1		2		3		4		5		6		7		8		9		10	
170DMHP9	#1	0.5	1.5	1.0	3.0	2.0	6.1	3.0	9.1	4.0	12.1	5.0	15.1	6.0	18.2	7.0	21.2	8.0	24.2	9.0	27.3	10.0	30.3
170DMHP34	#2	1.7	5.1	3.4	10.3	6.0	18.2	9.5	28.8	12.9	39.1	17.0	51.5	20.4	61.8	23.8	72.1	27.2	82.4	30.6	92.7	34.0	102.6

Series 170 MDC – Adjustable Low Pressure: 0 to 25 psi (1.72 bar) Maximum Discharge Pressure

MODEL TUBE FEED RATE CONTROL SETTING: Outputs per day in U.S. Gallons @ 60Hz (left) & Liters @ 50Hz (right) for primary feed rate only

MODEL	TUBE	L		1		2		3		4		5		6		7		8		9		10	
170MDC1	#1	0.3	0.9	0.5	1.5	1.0	3.0	1.5	4.5	2.0	6.1	2.5	7.6	3.0	9.1	3.5	10.6	4.0	12.1	4.5	13.6	5.0	15.1
170MDC2	#2	0.8	2.4	1.7	5.1	3.4	10.3	5.1	15.4	6.8	20.6	8.5	25.7	10.2	30.9	11.9	36.0	13.6	41.2	15.3	46.3	17.0	51.5
170MDC3	#3	2.0	6.1	4.0	12.1	8.0	24.2	12.0	36.3	16.0	48.5	20.0	60.6	24.0	76.7	28.0	84.8	32.0	96.9	36.0	109.0	40.0	121.1
170MDC4	#4	3.0	9.1	6.0	18.2	12.0	36.3	18.0	54.5	24.0	75.7	30.0	90.8	36.0	109.0	42.0	127.2	48.0	145.3	54.0	163.5	60.0	181.7
170MDC5	#5	4.3	13.0	8.5	25.7	17.0	51.5	25.5	77.2	34.0	103.0	42.5	128.7	51.0	154.4	59.5	180.0	68.0	205.9	76.5	231.6	85.0	257.4

Series 170 MDCHP – Adjustable High Pressure: 0 to 100 psi (6.9 bar) Maximum Discharge Pressure

MODEL TUBE FEED RATE CONTROL SETTING: Outputs per day in U.S. Gallons @ 60Hz (left) & Liters @ 50Hz (right) for primary feed rate only

MODEL	TUBE	L		1		2		3		4		5		6		7		8		9		10	
170MDCHP9	#1	0.3	0.9	0.5	1.5	1.0	3.0	1.5	4.5	2.0	6.1	2.5	7.6	3.0	9.1	3.5	10.6	4.0	12.1	4.5	13.6	5.0	15.1
170MDCHP34	#2	0.8	2.4	1.7	5.1	3.4	10.3	5.1	15.4	6.8	20.6	8.5	25.7	10.2	30.9	11.9	36.0	13.6	41.2	15.3	46.3	17.0	51.5

MOTOR PARTS

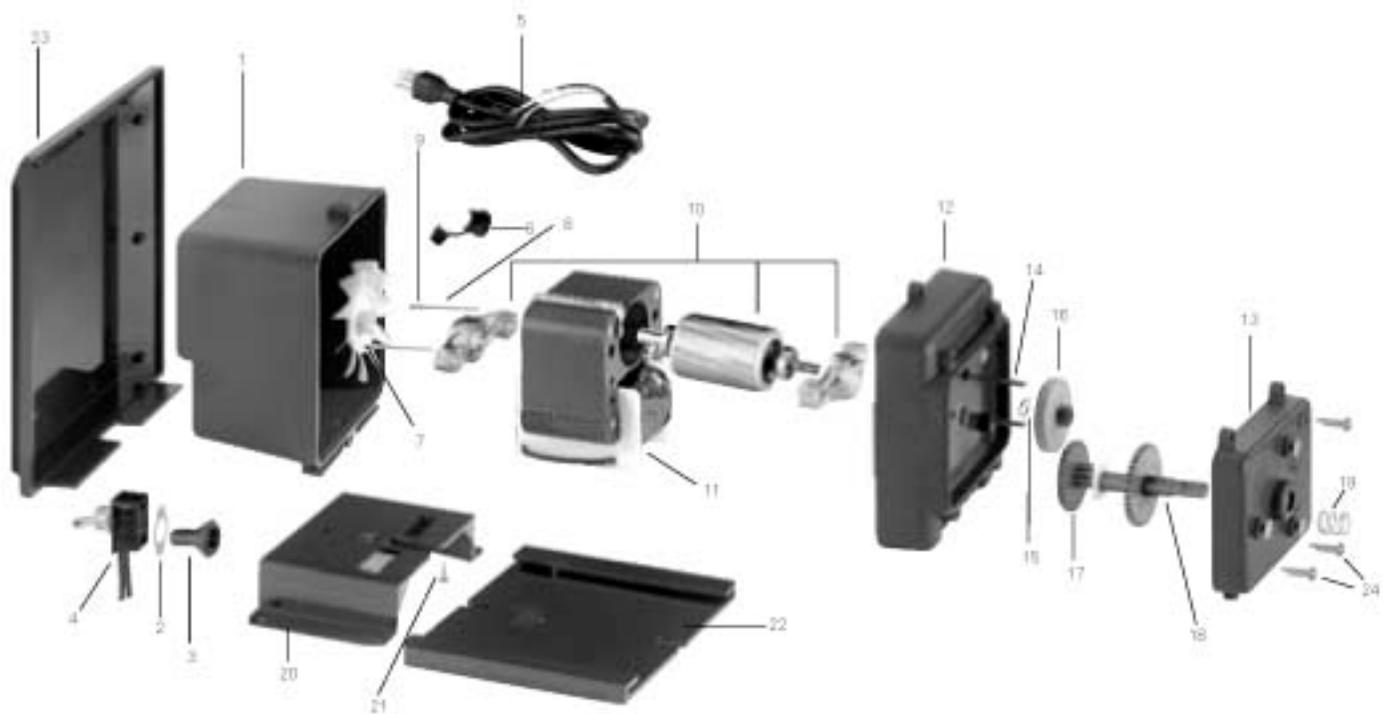

Gear Motor Parts

	UM	Part No.		UM	Part No.
1- Motor Cover with Cord (120v)	EA	PM6A0BL	12- Gear Case	EA	PM6K0BL
Motor Cover with Cord (220v)	EA	PM6A0OL	13- Gear Case Cover	EA	PM6R0BL
2- On-Off Switch Plate	EA	MP6D000	14- Gear Posts	EA	PM6M000
3- Switch Boot	EA	MP6C000	15- Thrust Washer	EA	MP6P000
4- Toggle Switch	EA	PM6E000	16- Phenolic Gear (26 RPM - Series 45 & 100)	EA	MP6N040
Wire Connector <i>not shown</i>	EA	PM6E001	Phenolic Gear (44 RPM - Series 85 & 170)	EA	MP6N080
5- Power Cord 120v	EA	MP6B010	17- Metal Reduction Gear (26 RPM - Series 45 & 100)	EA	MP6O040
Power Cord 220v	EA	MP6B020	Metal Reduction Gear (44 RPM - Series 85 & 170)	EA	MP6O080
6- Strain Relief Bushing	EA	MP6V000	18- Motor Shaft w/Gear (Adjustable Rate Models)	EA	MP6Q00D
7- Motor Fan	EA	PM6F000	Motor Shaft w/Gear (Single Head - Fixed Rate Models)	EA	ME6Q0LD
8- Coil Screw "G"	EA	PMS000G	Motor Shaft w/Gear (Double Head - Fixed Rate Models)	EA	DM6Q0LD
9- Lock Washer "F"	EA	PMS000F	19- Pressure Spring	EA	MP6T000
10- Rotor Assembly with Bearings, Brackets and Tolerance Rings	EA	PMBRPL2	20- Motor Base	EA	MP70000
11- Coil 120v 60Hz	EA	MP6J115	21- Motor Base Screw "D"	EA	PMS000D
Coil 220v 60Hz	EA	MP6J225	22- Mounting Bracket	EA	MP80000
Coil 230v 50Hz <i>International</i>	EA	MP6J223	23- Rain Roof	EA	MP90000
Coil 250v 50Hz <i>International</i>	EA	MP6J222	24- Cover Screw "B" (Package of 10)	PK	UCCPS0B
Motor Shaft Cup Bearing <i>not shown</i>	EA	PM6K001	Cover Screw "B" (Package of 24)	PK	MCCPS0B
			Coil Ground Screw "E" <i>not shown</i>	EA	PMS000E

All parts fit all Classic Series pumps unless otherwise noted.

FEED RATE CONTROLS AND PARTS

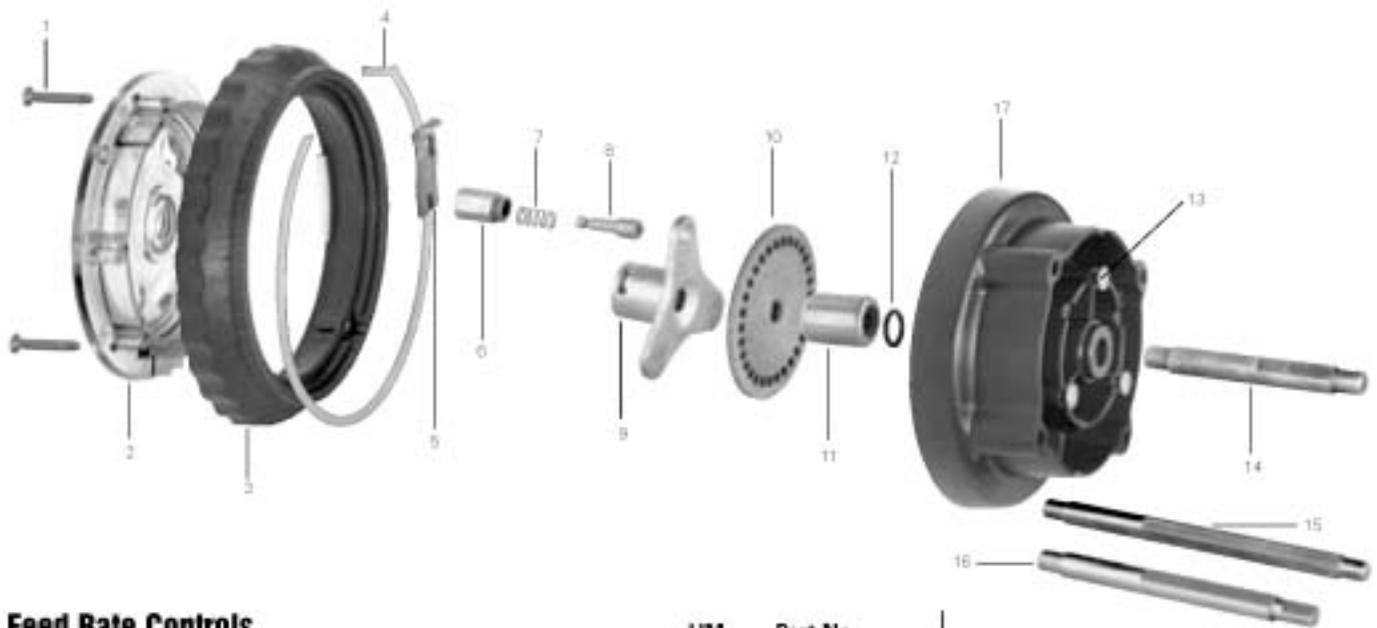

Feed Rate Controls

	UM	Part No.
Single Head Feed Rate Control w/Shaft	EA	FC5040D
Double Head Feed Rate Control w/Shaft	EA	DM5040D
Dual Head Dual Control Feed Rate Control w/Shaft	EA	DM504DC

Feed Rate Parts

	UM	Part No.
1- FRC Screw "A"	EA	FCS000A
2- Feed Rate Mounting Plate	EA	FC5N000
3- Dial Ring	EA	FC5M040
4- Variable Cam (Package of 2)	PK	UCFC5H0
Variable Cam (Package of 5)	PK	MCFC5H0
Index Pin Assembly with Lifter (Package of 1) <i>not shown</i>	PK	UCFC5AY
Index Pin Assembly with Lifter (Package of 2) <i>not shown</i>	PK	MCFC5AY
5- Index Pin Lifter (Package of 2)	PK	UCFC5L1
Index Pin Lifter (Package of 5)	PK	MCFC5L1
6- Index Pin Holder	EA	FC5L003
7- Index Pin Spring	EA	FC5L005
8- Index Pin	EA	FC5L002
9- Index Spider	EA	FC5K00D
10- Index Plate (Package of 1)	PK	UCFC5ID
Index Plate (Package of 5)	PK	MCFC5ID
11- Roller Clutch	EA	FC5F000
12- O-Ring Seal 3/8"	EA	FC5E000
13- Mounting Rivet "C"	EA	FCS000C
14- Main Shaft for Single Head-Adjustable Rate (Package of 1)	PK	UCFC5AD
Main Shaft for Single Head-Adjustable Rate (Package of 2)	PK	MCFC5AD
15- Main Shaft for Double Head Adjustable Rate	EA	DM5A00D
16- Main Shaft for Dual Head Dual Control – Adjustable Rate	EA	DM5A0DC
17- Feed Rate Housing w/Roller Clutch, Seal and Rivets	EA	FC5D00S



Patented Mechanical Control
Stenner's unique control mechanism allows output to be scaled from 5% to 100% with a simple turn of the dial. Numbers on the dial are in 10% increments, and each graduation marking represents a 2.5% step.

All parts fit all Classic Series pumps unless otherwise noted.

PUMP HEADS AND PARTS

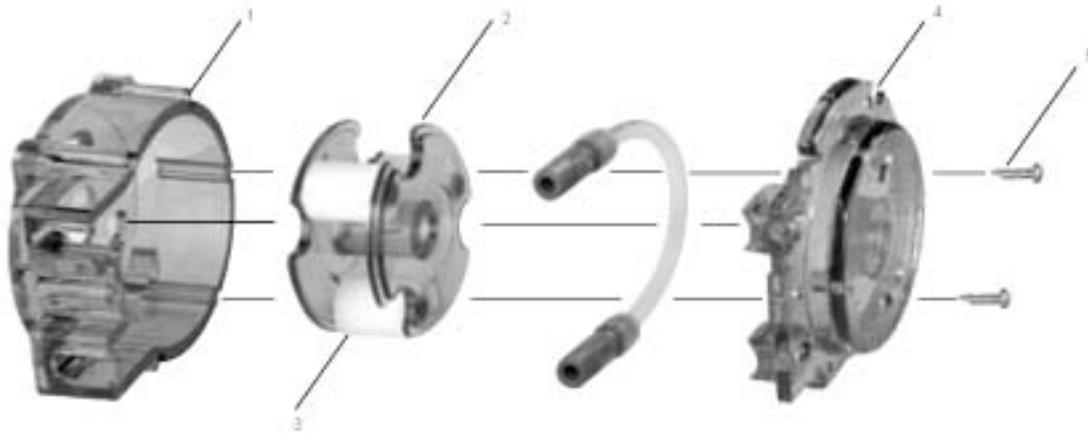

Prime Point

Never use lubrication grease or oil on the pump tube, pump head or roller assembly. Some types of grease and oil are incompatible with plastic parts and could cause failure.

Pump Heads (pump tube included)

	UM	Part No.
#1 Pump Head (Package of 1)	PK	UCTHC1D
#1 Pump Head (Package of 2)	PK	MCTHC1D
#2 Pump Head (Package of 1)	PK	UCTHC2D
#2 Pump Head (Package of 2)	PK	MCTHC2D
#3 Pump Head (Package of 1)	PK	UCTHC3D
#3 Pump Head (Package of 2)	PK	MCTHC3D
#4 Pump Head (Package of 1)	PK	UCTHC4D
#4 Pump Head (Package of 2)	PK	MCTHC4D
#5 Pump Head (Package of 1)	PK	UCTHC5D
#5 Pump Head (Package of 2)	PK	MCTHC5D
#7 Pump Head (Package of 1)	Single Head Only	PK UCTHC7D
#7 Pump Head (Package of 2)	Single Head Only	PK MCTHC7D

Pump Head Parts

	UM	Part No.
1- Tube Housing Only (Package of 1)	PK	UCCP400
Tube Housing Only (Package of 2)	PK	MCCP400
2- Roller Assembly – (Package of 1)	PK	UC3ASYD
Roller Assembly – (Package of 4)	PK	MC3ASYD
3- Standard Roller	EA	CP33000
4- Tube Housing Cover Bushing Included (Package of 1)	PK	UCCP100
Tube Housing Cover Bushing Included (Package of 4)	PK	MCCP100
5- Cover Screw "B" (Package of 10)	PK	UCCPS0B
Cover Screw "B" (Package of 24)	PK	MCCPS0B
Adapter Tube Housing Cover (Package of 1) <i>not shown</i>	PK	UCDM1A0
Adapter Tube Housing Cover (Package of 2) <i>not shown</i>	PK	MCDM1A0
Roller Shaft Bushing <i>not shown</i>	EA	CP31RSB
Tube Housing Cover Bushing Only <i>not shown</i>	EA	CP100CB

All parts fit all Classic Series pumps unless otherwise noted.

PUMP TUBES AND ADAPTER PUMP HEADS

PUMP TUBE ASSEMBLY NOTES:

- Stenner pump tubes (except #7) are interchangeable with all Stenner metering pumps. Pump output range can be changed by using a different pump tube.
- Pump tube fittings are stamped with numbers, 1-5 are rated for 0-25 psi back pressure and 1,2, & 7 are rated for 0-100 psi back pressure.
- Note: #7 pump tubes only fit single-head pumps for high-pressure applications.

Pump Tubes (ferrules included)

	UM	Part No.
#1 Pump Tube (Package of 2)	PK	UCCP201
#1 Pump Tube (Package of 5)	PK	MCCP201
#2 Pump Tube (Package of 2)	PK	UCCP202
#2 Pump Tube (Package of 5)	PK	MCCP202
#3 Pump Tube (Package of 2)	PK	UCCP203
#3 Pump Tube (Package of 5)	PK	MCCP203
#4 Pump Tube (Package of 2)	PK	UCCP204
#4 Pump Tube (Package of 5)	PK	MCCP204
#5 Pump Tube (Package of 2)	PK	UCCP205
#5 Pump Tube (Package of 5)	PK	MCCP205
#7 Pump Tube (Package of 2)	PK	UCCP207
#7 Pump Tube (Package of 5)	PK	MCCP207

Pump Tubes – International (6mm ferrules included)

#1 Pump Tube (Package of 2)	PK	UCCP21CE
#1 Pump Tube (Package of 5)	PK	MCCP21CE
#2 Pump Tube (Package of 2)	PK	UCCP22CE
#2 Pump Tube (Package of 5)	PK	MCCP22CE
#3 Pump Tube (Package of 2)	PK	UCCP23CE
#3 Pump Tube (Package of 5)	PK	MCCP23CE
#4 Pump Tube (Package of 2)	PK	UCCP24CE
#4 Pump Tube (Package of 5)	PK	MCCP24CE
#5 Pump Tube (Package of 2)	PK	UCCP25CE
#5 Pump Tube (Package of 5)	PK	MCCP25CE
#7 Pump Tube (Package of 2)	PK	UCCP27CE
#7 Pump Tube (Package of 5)	PK	MCCP27CE

Adapter Pump Heads (pump tube included)

	UM	Part No.
#1 Adapter Pump Head (Package of 1)	PK	UC1ATC1
#1 Adapter Pump Head (Package of 2)	PK	MC1ATC1
#2 Adapter Pump Head (Package of 1)	PK	UC1ATC2
#2 Adapter Pump Head (Package of 2)	PK	MC1ATC2
#3 Adapter Pump Head (Package of 1)	PK	UC1ATC3
#3 Adapter Pump Head (Package of 2)	PK	MC1ATC3
#4 Adapter Pump Head (Package of 1)	PK	UC1ATC4
#4 Adapter Pump Head (Package of 2)	PK	MC1ATC4
#5 Adapter Pump Head (Package of 1)	PK	UC1ATC5
#5 Adapter Pump Head (Package of 2)	PK	MC1ATC5

All parts fit all Classic Series pumps unless otherwise noted.

Prime Point

Schedule a regular pump tube maintenance change-out to prevent chemical damage to the metering pump or possible chemical spills.



#1 & #2 Pump Tube



#3 & #4 Pump Tube



#5 Pump Tube



#7 Pump Tube



Adapter Pump Head

PARTS



Connecting Nut 1/4"



Connecting Nut 3/8" with Adapter



Ferrules



Ceramic Weight with Clip



Injection Fitting 1/4"



Injection Check Valve 1/4"

Miscellaneous Parts

	UM	Part No.
Connecting Nut 1/4" (Package of 10)	PK	UCAK100
Connecting Nut 1/4" (Package of 24)	PK	MCAK100
Connecting Nut 3/8" with Adapter (Package of 2)	PK	UCADPTR
Connecting Nut 3/8" with Adapter (Package of 5)	PK	MCADPTR
Injection Point Cap 1/4" (Package of 5)	PK	UCAK101
Injection Point Cap 1/4" (Package of 24)	PK	MCAK101
Ferrule 1/4" (Package of 10)	PK	UCAK200
Ferrule 1/4" (Package of 24)	PK	MCAK200
Ferrule 6mm (Package of 24) <i>International</i>	PK	MCAK2CE
Ceramic Weight w/ 1/4" clip (Package of 1)	PK	UCMACW0
Ceramic Weight w/ 1/4" clip (Package of 5)	PK	MCMACW0
Ceramic Weight w/ 3/8" clip (Package of 1)	PK	UCMAC38
Ceramic Weight w/ 3/8" clip (Package of 5)	PK	MCMAC38
Ceramic Weight w/ 6mm clip (Package of 1) <i>International</i>	PK	UCMACCE
Suction/Discharge Tubing UV Black 20' x 1/4"	EA	AK4002B
Suction/Discharge Tubing White 20' x 1/4"	EA	AK4002W
Suction/Discharge Tubing UV Black 100' x 1/4"	EA	AK4010B
Suction/Discharge Tubing White 100' x 1/4"	EA	AK4010W
Suction/Discharge Tubing UV Black 1000' x 1/4"	EA	AK4100B
Suction/Discharge Tubing White 1000' x 1/4"	EA	AK4100W
Suction/Discharge Tubing UV Black 20' x 3/8"	EA	MALT02B
Suction/Discharge Tubing White 20' x 3/8"	EA	MALT002
Suction/Discharge Tubing UV Black 100' x 3/8"	EA	MALT10B
Suction/Discharge Tubing White 100' x 3/8"	EA	MALT010
Suction/Discharge Tubing UV Black 1000' x 3/8"	EA	MALTB10
Suction/Discharge Tubing White 1000' x 3/8"	EA	MALT100
Suction/Discharge Tubing White 20' x 6mm <i>International</i>	EA	AK20W6M
Foot Valve Strainer	EA	MAFVSST
Foot Valve Strainer 3/8"	EA	MAFVST3
Suction Line Strainer with Ferrule & Nut 1/4"	EA	MASST00
Suction Line Strainer with Ferrule & Nut 3/8"	EA	MASST03
Grease (8 oz. tube)	EA	MAGCSGR

Check Valve Parts

	UM	Part No.
Injection Fitting w/ Nut & Ferrule 1/4" (Package of 1)	PK	UCAK300
Injection Fitting w/ Nut & Ferrule 1/4" (Package of 5)	PK	MCAK300
Injection Fitting w/ Nut & Ferrule 6mm (Package of 1) <i>International</i>	PK	UCAK3CE
Injection Check Valve 1/4" (Package of 1)	PK	UCDBINJ
Injection Check Valve 1/4" (Package of 5)	PK	MCDBINJ
Injection Check Valve 3/8" (Package of 1)	PK	UCINJ38
Injection Check Valve 3/8" (Package of 5)	PK	MCINJ38
Injection Check Valve 6mm (Package of 1) <i>International</i>	PK	UCINJCE

All parts fit all Classic Series pumps unless otherwise noted.

Check Valve Parts...Continued

	UM	Part No.
Check Valve Duckbill Only (Package of 2)	PK	UCCVDB0
Check Valve Duckbill Only (Package of 5)	PK	MCCVDB0
Check Valve Body Only 1/4"	EA	CVF1/4
Check Valve Body Only 3/8"	EA	CVF3/8
Check Valve Injection Fitting Only 1/4"	EA	CVIJ1/4
Check Valve Injection Fitting Only 3/8"	EA	CVIJ3/8
Check Valve O-Ring	EA	CVIJOR

Accessory Kits

Accessories in each kit are based on pressure rating (25 psi or 100 psi), connection size (1/4", 3/8" or 6mm) and suction/discharge color. Double Head or Dual Control models will have two kits per metering pump.

- (3) Connecting nuts (1/4" or 3/8")
- (3) Ferrules
- (1) Injection check valve (0-100 psi) or (1) Injection Fitting (0-25 psi)
- (1) Ceramic weight with clip
- (1) 20' roll of 1/4", 3/8" or 6mm suction/discharge tube (white or UV black)
- (1) Spare pump tube
- (1) Installation and maintenance manual

High Pressure (0-100 psi) Choose #1, 2 or 7 pump tube

	UM	Part No.
Accessory Kit with #__ Tube & 1/4" White Suction/Discharge	EA	HPACK_
Accessory Kit with #__ Tube & 1/4" UV Black Suction/Discharge	EA	HPACK_B
Accessory Kit with #__ Tube & 3/8" White Suction/Discharge	EA	MAHPK_
Accessory Kit with #__ Tube & 3/8" UV Black Suction/Discharge	EA	MAHPK_B
Accessory Kit with #__ Tube & 6mm White Suction/Discharge <small>International</small>	EA	CEHPK_

Low Pressure (0-25 psi) Choose #1-5 pump tube

	UM	Part No.
Accessory Kit with #__ Tube & 1/4" White Suction/Discharge	EA	CPACK_
Accessory Kit with #__ Tube & 1/4" UV Black Suction/Discharge	EA	CPACK_B
Accessory Kit with #__ Tube & 3/8" White Suction/Discharge	EA	MAACK_
Accessory Kit with #__ Tube & 3/8" UV Black Suction/Discharge	EA	MAACK_B
Accessory Kit with #__ Tube & 6mm White Suction/Discharge <small>International</small>	EA	CEACK_

All parts fit all Classic Series pumps unless otherwise noted.



Check Valve Duckbill



Check Valve O-Ring



Check Valve Body Only 1/4"



Check Valve Body Only 3/8"

LIMITED WARRANTY AND SERVICE POLICY

Damaged or Lost Shipments

UPS and prepaid truck shipments: Check your order immediately upon arrival. All damage must be noted on the delivery receipt. Call Stenner Customer Service at 800-683-2378 for all shortages and damages within seven (7) days of receipt.

Returns

Stenner offers a 30-day return policy. Except as otherwise provided, no material will be accepted for return after 30 days from purchase. To return merchandise at any time, call Stenner at 800-683-2378 for a Returned Goods Authorization (RGA) number. A 15% re-stocking fee will be applied. Include a copy of your invoice or packing slip with your return.

Limited Warranty

G. H. Stenner & Co., Inc. will for a period of one (1) year from the date of purchase (proof of purchase required) repair or replace – at our option – all defective parts. G. H. Stenner & Co., Inc. is not responsible for any removal or installation costs. Pump tube assemblies and rubber components are considered perishable and are not covered in this warranty. Pump tube will be replaced each time a pump is in for service, unless otherwise specified. The cost of the pump tube replacement will be the responsibility of the customer. G. H. Stenner & Co., Inc. will incur shipping costs for warranty products shipped from our factory in Jacksonville, Florida. Any tampering with major components, chemical damage, faulty wiring, weather conditions, water damage, power surges, or products not used with reasonable care and maintained in accordance with the instructions will void the warranty. G. H. Stenner & Co., Inc. limits its liability solely to the cost of the original product. We make no other warranty expressed or implied.

Disclaimer

The information contained in this manual is not intended for specific application purposes. G. H. Stenner & Co., Inc. reserves the right to make changes to prices, products, and specifications at any time without prior notice.



3174 DeSalvo Road
Jacksonville, Florida 32246
sales@stenner.com

www.stenner.com

Phone: 904-641-1666
US Toll Free: 800-683-2378
Fax: 904-642-1012

Hours of Operation (EST):
Mon. – Thu. 7 AM – 5 PM
Friday 7 AM – Noon