

WATERGROUP

WGR Series

Reverse Osmosis System

Installation, Operation, and Service Manual

WGR-150

WGR-300

WGR-450

WARNING

This Reverse Osmosis System contains a preservative solution to prevent microbiological growth and freezing which if ingested, may cause irritation of the gastrointestinal tract, colic, diarrhea or other similar symptoms. Therefore the unit should be flushed for 2 hours prior to use. The water should be disposed of immediately.

Table Of Contents

Introduction To Reverse Osmosis (RO).....	3
Common Terms & Definitions.....	3
How Reverse Osmosis Works.....	4
Factors Affecting Performance.....	4
Pressure.....	4
Temperature.....	4
Recovery.....	5
Feed water Concentration.....	5
Bacteria.....	5
Hydrolysis.....	5
WATERGROUP WGR Series Specifications.....	6
System Components.....	7
1. Feed Water Pressure Gauges.....	7
2. System Pressure Gauge.....	7
3. Process Pump.....	7
4. Operating Pressure Control.....	7
5. Pump Motor.....	7
6. Low Pressure Switch.....	8
7. Tank Full Switch.....	8
8. Float Switch (optional).....	8
9. Pressure Regulator.....	8
10. Pre-Filter.....	8
11. Carbon Filter.....	8
12. Inlet Solenoid Valve.....	9
13. Manual Flush Valve.....	9
14. Pre-Filter Isolation Valve.....	9
Installation Instructions.....	10
Location.....	10
Water Supply Connection.....	10
Product Water Connection.....	10
Reject Water Connections.....	10
Electrical Connections.....	11
Float Switch Connections.....	11
Start-up Procedure.....	12
Pre-Start Check List.....	12
Start-Up.....	12
Maintenance.....	13
Pump.....	13
Reverse Osmosis Membranes.....	13
Flushing Membrane.....	13
Membrane Removal and Replacement.....	13
TDS Reading.....	14
Filters.....	14
Trouble Shooting.....	15
Warranty.....	17
Parts List.....	18

Introduction To Reverse Osmosis (RO)

Common Terms & Definitions

Feed Water - The water that is introduced to the RO membrane for purification.

Product Water - The purified water produced by the RO unit.

Waste Water - The water that does not pass through the RO membrane. This water is to be directed to a drain.

Membrane - The fabric that the feed water passes through to become product water. It is usually a large surface area sheet that is spiral wound into a tube shape. It has channels for product flow and removal once the feed water has passed through the membrane.

Module - This is the completed package with the RO membrane installed inside the pressure vessel.

Gallons per Day (GPD) - RO systems are normally sized with this rating. A 450 GPD rating means this unit could produce 450 gallons per day of purified water at a given temperature.

TDS - Total Dissolved Solids. This is a measure of product water purity, measured in parts per million.

Parts per Million (ppm) - The measure of TDS. The parts of Total Dissolved Solids per one million parts of water (i.e. one pound of mineral salts dissolved in one million pounds of water will give one part per million of TDS).

Percent Recovery - The amount of feed water that passes through the membrane to become product water (i.e. If 1000 gallons of feed water are introduced to the RO system and 500 gallons of product water are produced then the percent recovery would be 50%).

Percent Rejection - The amount of total dissolved solids or chemicals rejected by the RO membrane.

Turbidity - Suspended biological, inorganic and organic particles in water which may be in sufficient amount to make the water seem cloudy.

How Reverse Osmosis Works

Osmosis is the process by which water moves across a semi-permeable membrane from a low concentration of solute to a high concentration of solute. Reverse osmosis depends on the presence of a barrier or membrane that is selective so that solvent of a solution can pass through the membrane while other components of the solution cannot. The osmotic pressure is the pressure required to stop the flow of solvent through a semi-permeable membrane separating two solutions of different concentrations. To separate water from dissolved solids by reverse osmosis, the applied pressure must be greater than the osmotic pressure.

Reverse osmosis is the finest level of filtration available. The RO membrane acts as a barrier to all dissolved salts and inorganic molecules, as well as organic molecules with molecular weight greater than approximately 100. Water molecules on the other hand pass freely through the membrane creating a purified product stream. Rejection of dissolved salts is typically 95% to greater than 99%.

Factors Affecting Performance

Permeate flux and salt rejection are the key performance parameters of the reverse osmosis process. They are mainly influenced by variable parameters such as; pressure, temperature, recovery, and feed water salt concentration.

Pressure

Increased feed water pressure will increase permeate flux and decrease the permeate TDS. With excessive pressure the membrane may become deformed or compacted and a decrease in product flow will result.

Temperature

Increased temperature will increase permeate flux, which increases salt passage. It is also important to note that every unit is rated for a product flow temperature of 77°F (25°C). With a temperature decrease, the product flow will decrease. On average the membranes lose about 2% production for every degree below 77°F.

Recovery

The recovery is the ratio of the permeate flow to the feed flow. When recovery is increased, the permeate flux will decrease and the salt passage will increase.

Feed water Concentration

Increased TDS or salt concentrations will decrease permeate flux and increase salt passage. This can also lead to surface coating or fouling by the salt.

Bacteria

If bacteria is allowed to grow on the membrane it will digest the top layer of the membrane and reduce the ability of the membrane to reject salt.

Hydrolysis

This is the effect of chemicals in the feed water on the membrane. This happens when the water temperature is high and the pH of the water is above 7 and below 2.5. To achieve optimum membrane life, a pH between 5 and 6 should be maintained.

WATERGROUP WGR Series Specifications

Model	Membrane Element	Number of Elements	Motor HP*
WGR-450	FILMTEC - TW30-2521	1	1/3
	FILMTEC - TW30-2514	1	
WGR-300	FILMTEC - TW30-2521	1	1/3
WGR-150	FILMTEC - TW30-2514	1	1/4

*(115 V, 60 HZ, 1 pH)

Filters	Size	Type
Sediment Filter	10"	5 μ m
Carbon Filter	10"	GAC

Operating Limits

Membrane Type	Thin Film Composite
Maximum Operating Pressure	200 psi
Feed Line Pressure Min./Max.	30-85 psi
pH Range, Continuous	2 - 11
Feed Water Hardness	<10 gpg
Feed Water Iron	<0.1 ppm
Feed Water Manganese	<.05 ppm
Feed Water Hydrogen Sulfide	must be removed
Chlorine Tolerance	0 ppm
Organics Tolerance	0 ppm
Oil Tolerance	0 ppm
Maximum Allowable Back Pressure	40 psi
Operating Temperature	40-110 °F
Maximum Feed Turbidity	1 NTU
Maximum Feed Silt Density Index	SDI 5
Maximum TDS	2000 ppm

Note: Operating in excess of these conditions may result in more frequent cleaning or premature failure of the membrane. The limited warranty will become void if failure or reduced performance is due to improperly treated feed water

System Components

1. Feed Water Pressure Gauges

The inlet pressure gauge reads the feed water pressure. The second pressure gauge, after the sediment filter and carbon filter, reads the water pressure entering the process pump. As the filters become clogged, a pressure drop will develop across the filters. A pressure drop of 7 psi or more will indicate the need to check or replace filters.

2. System Pressure Gauge

This gauge indicates the water pressure that is being discharged by the pump and applied to the first R.O. membrane. The recommended system operating pressure is 200 psi. This should not be exceeded.

3. Process Pump

The R.O. unit uses a rotary vane positive displacement pump. It has a brass external housing with stainless steel internal components. Maximum discharge pressure for the pump is 200 psi.

4. Operating Pressure Control

The maximum system operating pressure is controlled by a built in by-pass in the positive displacement pump. The pump is factory pre-set for 200 psi. In the event an adjustment is required, turn the slot blade screw to the right for higher pressure and to the left to decrease the pressure.

5. Pump Motor

The electrical service required for the motors is 120 V, 60 HZ, single phase. Verify that available power exactly matches the voltage, hertz, and phase on the motor name plate before connecting any power to the unit. Connecting the unit to a power source which does not match the unit power rating exactly may cause damage and void the warranty.

6. Low Pressure Switch

The low pressure switch will automatically shut down the system should the feed water pressure drop below 15 psi. The system will re-start when the pressure rises to 25 psi. Operating the system below feed water pressure of 20 psi will cause pump damage.

7. Tank Full Switch

The system is designed for pressurized storage tank system. The system will shut down when the storage tank pressure reaches 50 psi. It will re-start when the storage tank pressure drops below 30 psi.

8. Float Switch (optional)

The system can be used in conjunction with an atmospheric tank as well. A float switch installed in the tank will measure tank level and turn the RO system on when levels are low and off when levels are high.

9. Pressure Regulator

This valve controls of the amount of concentrate being recycled to the feed inlet of the pump. It is also used to fine tune and adjust the system pressure. **WARNING - DO NOT TURN THE PRESSURE ADJUSTMENT ALL THE WAY OUT. IT WILL COME OFF THE THREADS AND MAY CAUSE INJURY BY SHOOTING UPWARDS.**

10. Pre-Filter

This filter is a 10" sediment filter that removes suspended particles such as dirt or scale down to 5 micron in size.

11. Carbon Filter

This is a 10" granular activated carbon filter. It removes chlorine from the feed water. Chlorine will attack and destroy thin film composite membranes.

12. Inlet Solenoid Valve

This 1/2" normally closed solenoid valve opens to allow feed water into the system when feed pressure rises above 25 psi and shuts off when pressure falls below 15 psi to ensure that damage does not occur to the pump.

13. Manual Flush Valve

This 1/4" ball valve can be manually opened when the unit is in operation to fast flush the membranes. The waste water is diverted through a bypass around the waste water valve and recycle valve to drain.

NOTE: Open and close valve slowly as system pressure is reduced and increased greatly during operation of the flush valve.

14. Pre-Filter Isolation Valve

This 1/4" ball valve is the inlet connection for the feed water to the system. It allows the feed water to be turned off directly on the unit.

Installation Instructions

Important: The WGR system must comply with all local plumbing, sanitation, and electrical codes. Obtaining permits and meeting codes is the responsibility of the installer.

Location

The WGR system should be positioned in a suitable location near inlet water, drains, and electrical outlet. The unit should be located indoors on a solid level base which can support the weight of the unit. Allow enough space for servicing of the unit and removal of the membranes.

Install the unit away from direct sunlight in a well ventilated location. Ensure that the system is protected from weather or excessive dust.

Dimensions: height -- 30"
width -- 15"
Depth -- 18"

Water Supply Connection

Caution: Use only Non-Ferrous materials when connecting the water supply to the WGR system. Iron is detrimental to the membrane and causes fouling and pre-mature failure of the membrane.

The water supply connection is 1/4" FNPT on pre-filter isolation valve. Run 1/2" or 3/8" softened water supply line to the valve.

Product Water Connection

The WGR system comes with 10 ft of blue 3/8" tubing running from the product water flow meter. This tubing is to be connected to the storage tank using 3/8" compression tubing fittings.

Reject Water Connections

The WGR system comes with 10 ft of black 3/8" tubing running from the waste water flow meter. This tubing should be run to a suitable drain (floor drain or stand pipe) This connection should include a proper air gap to prevent possible

back flow. (Consult local plumbing codes) Ensure that the drain line tubing is fastened securely. When the system goes into fast flush mode, considerable pressure is applied and the tubing may come loose.

Electrical Connections

Verify that the available power exactly matches the voltage, hertz, and phase specified on the systems name plate before connecting any power to the unit.

Caution: Connecting the unit to a power source which does not exactly match the unit power rating exactly may cause damage and void the warranty.

Float Switch Connections

A float switch can be supplied by the manufacturer for this system. The float switch will come with a plug in that the RO unit plugs into. The other end of the piggy back then is plugged into the wall outlet. This will cut power to the RO unit when the atmospheric tank is full and restore power when tank is empty. The mechanical float switch works on a 45 degree angle for pump on and off levels.

Optional

A float switch may be connected to this system for use with an atmospheric tank. Remove the pressure switch covers from both the low pressure and tank full switches. Disconnect the black wire at both ends of the cable connecting the two pressure switches. Connect the black and white wires of the float switch to the pressure switch where the old black ones were. Replace the pressure switch covers.

Start-up Procedure

Before running the RO system the granular activated carbon filter has to be flushed. To do this place the carbon filter into the first filter housing and leave the second filter housing removed. Place a bucket under the second filter top to catch runoff. Open the pre filter isolation ball valve and flush for 2 minutes. Throw waste water away. Once the carbon filter has been washed install it in the second housing and replace the sediment filter into the first housing.

Pre-Start Check List

1. Sediment filter and Carbon filters in place.
2. Minimum inlet pressure 30 psi.
3. System is plugged into proper electrical supply.
4. Black waste water and blue product water lines are connected to drain and storage tank.
5. Carbon filter has been flushed to remove excess carbon.
6. Open pressure regulator almost completely. **WARNING - DO NOT TURN THE PRESSURE ADJUSTMENT ALL THE WAY OUT. IT WILL COME OFF THE THREADS AND MAY CAUSE INJURY BY SHOOTING UPWARDS.**

Start-Up

1. Open pre-filter isolation valve.
2. Check that the manual flush valve is in the open position. The valve is open when the handle is in line with the valve.
3. Immediately monitor the system pressure gauge to insure that the system does not exceed 200 psi.
4. With pump running, slowly close the manual flush valve. Immediately monitor the system pressure gauge to insure that the system does not exceed 200 psi.
5. With pump running, slowly close the pressure regulator until the system pressure reaches 150 psi. Observe that as the regulator is closed, the system pressure increases. Do not let the system pressure go over 200 psi. If necessary, open the regulator to lower system pressure. By continuing this fine tuning process, the desired system pressure can be achieved
6. To check the operation of the low pressure switch, slowly close the pre-filter isolation valve. The system should shut down at 15 psi. Slowly open the valve and the system should initiate start-up at 25 psi.
7. Leave the system running until the storage tank fills to ensure proper operation of the tank full switch.
8. The system should stabilize after 20-30 minutes of operation.

Maintenance

Pump

The process pump requires no regular maintenance. When the pump becomes noisy or 190 psi system operating pressure cannot be maintained, the pump should be replaced. At operating pressures above 190 psi, the life of the pump is reduced. If the feed water is very high in TDS the bypass pressure regulator on the pump may be scaling up causing water to bypass in the pump. Remove the acorn nut on the bypass and clean any scale off. If pressure does not return to normal, replace the pump.

Reverse Osmosis Membranes

The condition of the membranes is indicated by comparing the current permeate water quality (TDS) and production to the baseline permeate quality and production values that were established upon initial installation.

Flushing Membrane

Organic and or mineral sludge tends to build up on the surface of the membrane that can reduce its performance. Open the manual flush valve located on the back of the system slowly and let the unit fast flush for five minutes. Once a week flushing is helpful. In some cases, once a day flushing may be desired to control odor from organic build up.

Membrane Removal and Replacement

Disconnect all piping connected to the membrane at the point closest to the membrane. Remove the membrane and housing from the RO unit. Remove the 'U' bolt at the bottom of the membrane. The end cap will only have one hole. This should be the high pressure end. This end has a brine seal which forces the water to pass through the inside of the membrane. Carefully remove the end cap from the vessel using a pulling/twisting motion.

Remove the membrane from the pressure vessel by pulling on the product water tube. If additional force is required, pliers in tape wrapped could be used for removal. Check the internal and external 'o' rings for wear or damage. If damage is evident they must be replaced

Re-install membrane in the same manner as it was removed. Slide end cap back into the membrane and replace the 'U' bolt. Replace all piping that was removed. Test membrane for any leaks. Once all leaks are repaired, restart the unit using normal start-up procedures.

TDS Reading

After initial installation, check and note the TDS of the product water using a portable hand held TDS meter. Subsequent readings should be compared to this reading to determine whether any potential problems are developing. Over a period of time, a gradual increase in product water TDS can be expected. Rapid increases require further attention.

Product water TDS can increase by one or more of the following factors;

1. Increase in feed water TDS
2. Membrane is fouled with mineral salts due to a recovery rate that is too high.
3. Carbon filter is exhausted and no longer removing chlorine. Chlorine will permanently damage the membrane.
4. Membrane is fouled with biological contamination such as algae or bacteria.

Filters

When a large pressure differential (7 psi or more) develops across the 5 micron sediment filter and the granular activated carbon filter, they should be replaced.

The activated carbon filter reduces volatile organic compounds and removes chlorine. When the permeate water shows the first sign of objectionable taste or odor, the carbon filter is nearly expended. It should be changed every 3-6 months or sooner if chlorine is detected after the cartridge filter.

Trouble Shooting

Problem	Probable Cause	Solution
R.O. UNIT WILL NOT START	No electrical power to control circuit	Check power supply, circuit breakers, fuses etc.
	Storage tank full	Drain portion of water from storage tank
	Low feed pressure	Check feed water supply
	Pump motor	Check or replace
	Pressure or float switch defective	Check or replace
LOW FEED PRESSURE	Feed water valve turned off	Check
	Feed water solenoid defective	Check or replace
	Obstructed feed line	Check
	Upstream pre-treatment	Check
	Inlet feed pressure	Check
NO HIGH SYSTEM PRESSURE	System pressure gauge broken	Check and replace
	Pump impellers worn	Check and replace
	Low water volume to pump	Check
	Malfunctioning pump	Check, replace if necessary
NO REJECT WATER	Clogged drain line	Check and clean
NO PRODUCT WATER	Low pump pressure	Check and adjust
	Membrane plugged	Check, clean, or replace
	Low water temperature	Check
LOW FLOW RATE	Membrane fouled	Check, clean, or replace
	Product water check valve stuck	Replace
HIGH PRODUCT	Membrane expended	Replace

WATER TDS	<p>Insufficient brine flow</p> <p>Increase in feed water TDS</p> <p>Membrane brine seal not sealed against membrane housing</p>	<p>Replace or flush concentrate valve</p> <p>Check</p> <p>Check brine seal, use care when re-installing</p>
BAD TASTING WATER	<p>Filter Cartridges exhausted</p> <p>Tank and system contaminated</p> <p>Tank diaphragm ruptured</p> <p>Cartridge not flushed completely</p>	<p>Replace</p> <p>Replace filters and sanitize the tank</p> <p>Re-sterilize tank</p> <p>Flush one or two tanks of pure water through</p>
CLOUDY WATER	<p>Dissolved air in feed water is concentrated in the product water</p>	<p>Usually clears up as condition of feed water changes. Letting water stand for a few minutes will allow the air to dissipate</p>

Warranty

WATERGROUP warrants that each WGR system has been factory tested to perform in accordance with published specifications at the time of delivery. The company further warrants that a WGR system will continue to make potable water for a period of 1 year with the exception of the membrane which is prorated over a period of 24 months, providing the user supplies feed water meeting minimum standards and adopts and implements the maintenance program recommended in the WGR operation manual.

Expendable or consumable products, filter cartridges, chemicals, etc. which by nature have a shorter life expectancy than twelve months are not covered under this warranty.

The company's liability under this warranty is limited to the repair or replacement at the company's discretion of systems or components found defective solely as to materials or workmanship during the warranty term. The replacement will be on an exchange basis from the factory direct or arranged through WGR dealer or distributor (no labor, transportation or mileage charges will be reimbursed). If a complete system is returned to the factory (freight prepaid), WATERGROUP COMPANIES will repair or replace the unit at WATERGROUP COMPANIES discretion free of charge (except transportation) if the unit is determined to be defective under this warranty.

This warranty does not extend to any system or components which failed due to (1) damage from mishandling, misuse, substandard feed water, improper maintenance procedures, or neglect, (2) improper installation (3) incorrect electrical supply. This warranty is void if serial numbers are mutilated or missing.

Our obligations under this warranty are limited to repair or replacement of defective parts and we assume no liability whatsoever for incidental or consequential damage.

Parts List

Drawing Part #	Description	Item #
1	Powder coated steel bracket	92270
2	Pressure gauge, 0-300 psi	101051
3	Pressure switch, 15 - 25 psi	101031
4	Pressure switch, 30 - 50 psi	101032
5	Pressure gauge, 0 - 100 psi	101047
6	5 micron sediment filter, 10"	92091
7	Radial flow carbon filter, 10"	92081
8	Brass pressure regulator	965646
9	150 gpd flow restrictor	92462
10	300 gpd flow restrictor	92463
11	450 gpd flow restrictor	92464
12	Manual Flush Ball valve, 1/4" npt	80702
13	Solenoid valve, 1/2" npt	80307
14	Membrane housing, SS, 14"	92030
15	Membrane housing, SS, 21"	92029
16	Pump, po201, 68 gph	74906
17	Pump, po2501, 85 gph	74907
18	Electric motor, 1/4 hp	100785
19	Electric motor, 1/3 hp	100786
20	Membrane, 14", thin film composite	92011
21	Membrane, 21", thin film composite	92007

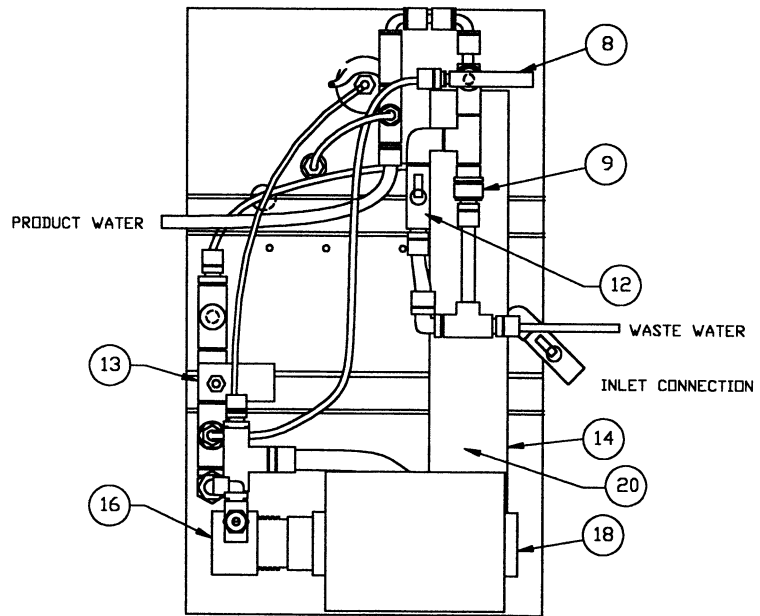
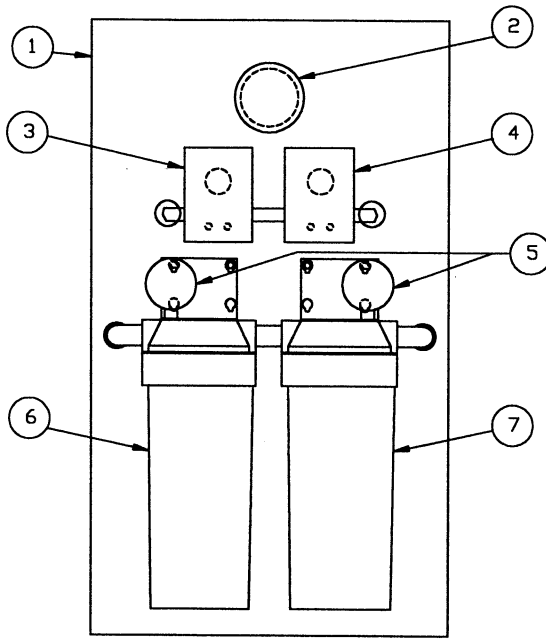

DESIGNED BY: T. HUGHES			
DRAWN BY: J. NICHOLS			
CHECKED BY:			
DATE: 29 JULY, 1997			
MATERIAL:	TITLE: WGR - 150 SCHEMATIC		
SCALE:			
TOLERANCES:	SIZE:	NO. R-1080 SH. 1 OF 1 SHEETS	REV.

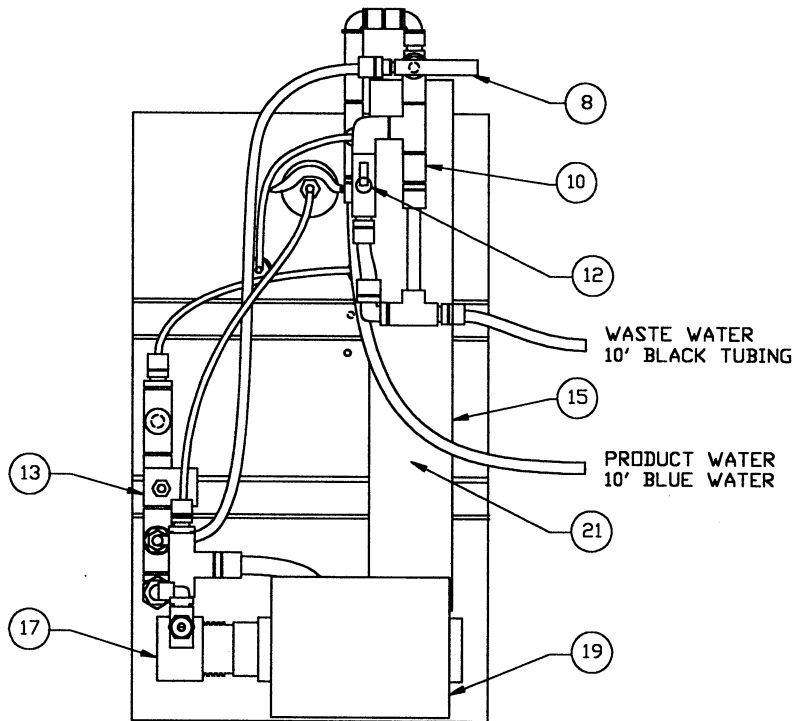
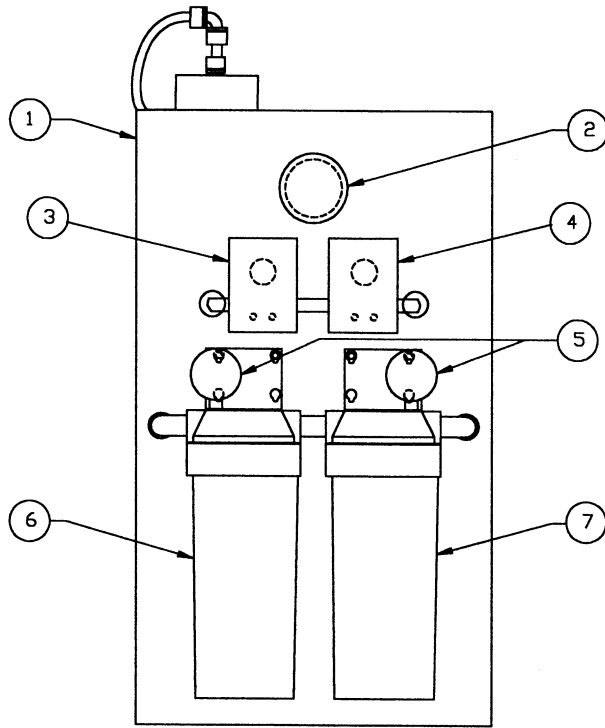

DESIGNED BY: T. HUGHES					
DRAWN BY: J. NICHOLS					
CHECKED BY:					
DATE: JULY 29, 1997	TITLE: WGR - 300 SCHEMATIC				
MATERIAL:					
SCALE: NTS					
TOLERANCES:					
SIZE:	NO. R-1081	SH. 1	OF 1	SHEETS	REV.

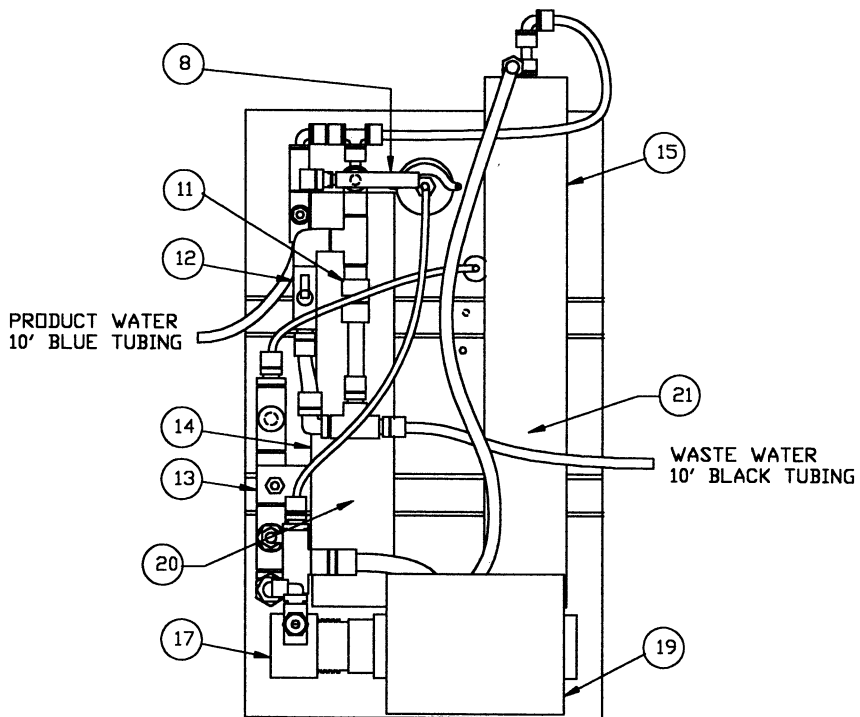
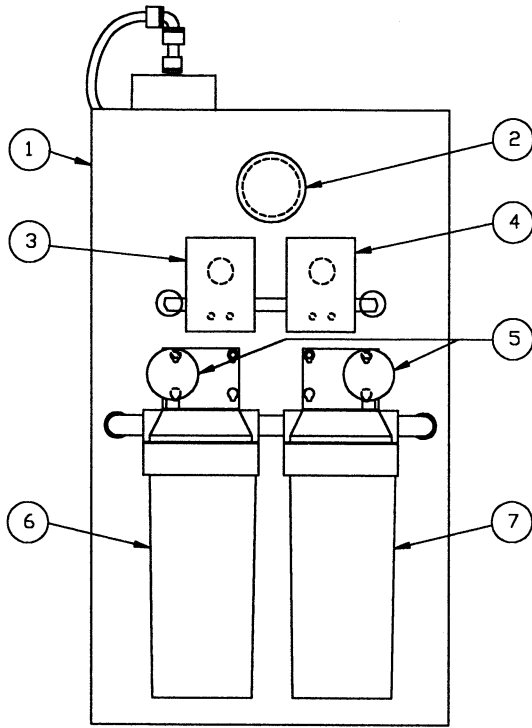

DESIGNED BY: T. HUGHES			
DRAWN BY: J. NICHOLS			
CHECKED BY:			
DATE: JULY 29, 1997			
MATERIAL:	TITLE: WGR - 450 SCHEMATIC		
SCALE: NTS			
TOLERANCES:	SIZE:	NO. R-1080 SH. 1 OF 1 SHEETS	REV.

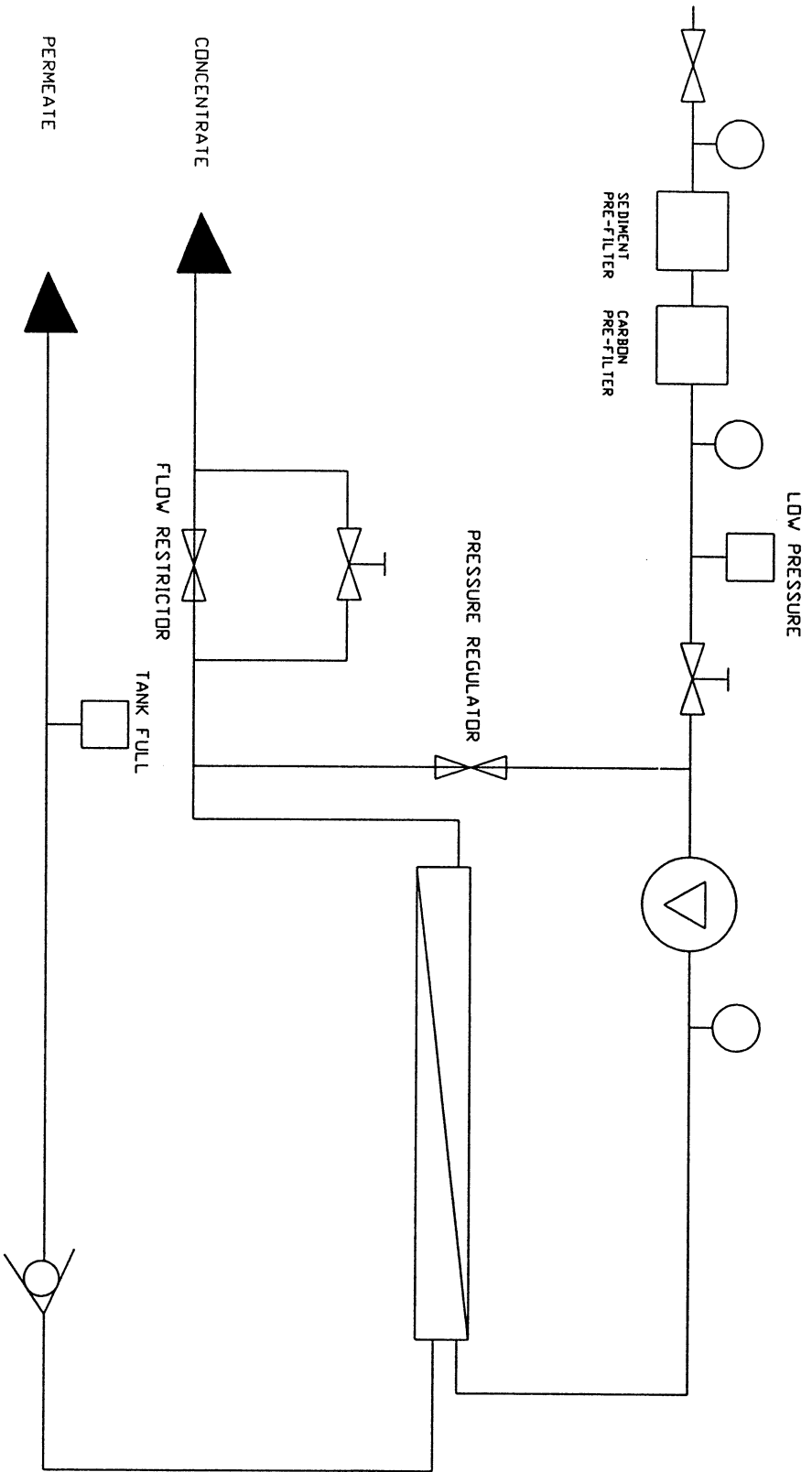

- LEGEND**
- PROCESS PUMP
 - PRESSURE GAUGE
 - ISOLATION VALVE
 - SOLENOID VALVE
 - NEEDLE VALVE
 - PRESSURE SWITCH
 - FLOW METER
 - PRE-FILTER
 - CHECK VALVE
 - CONDUCTIVITY PROBE



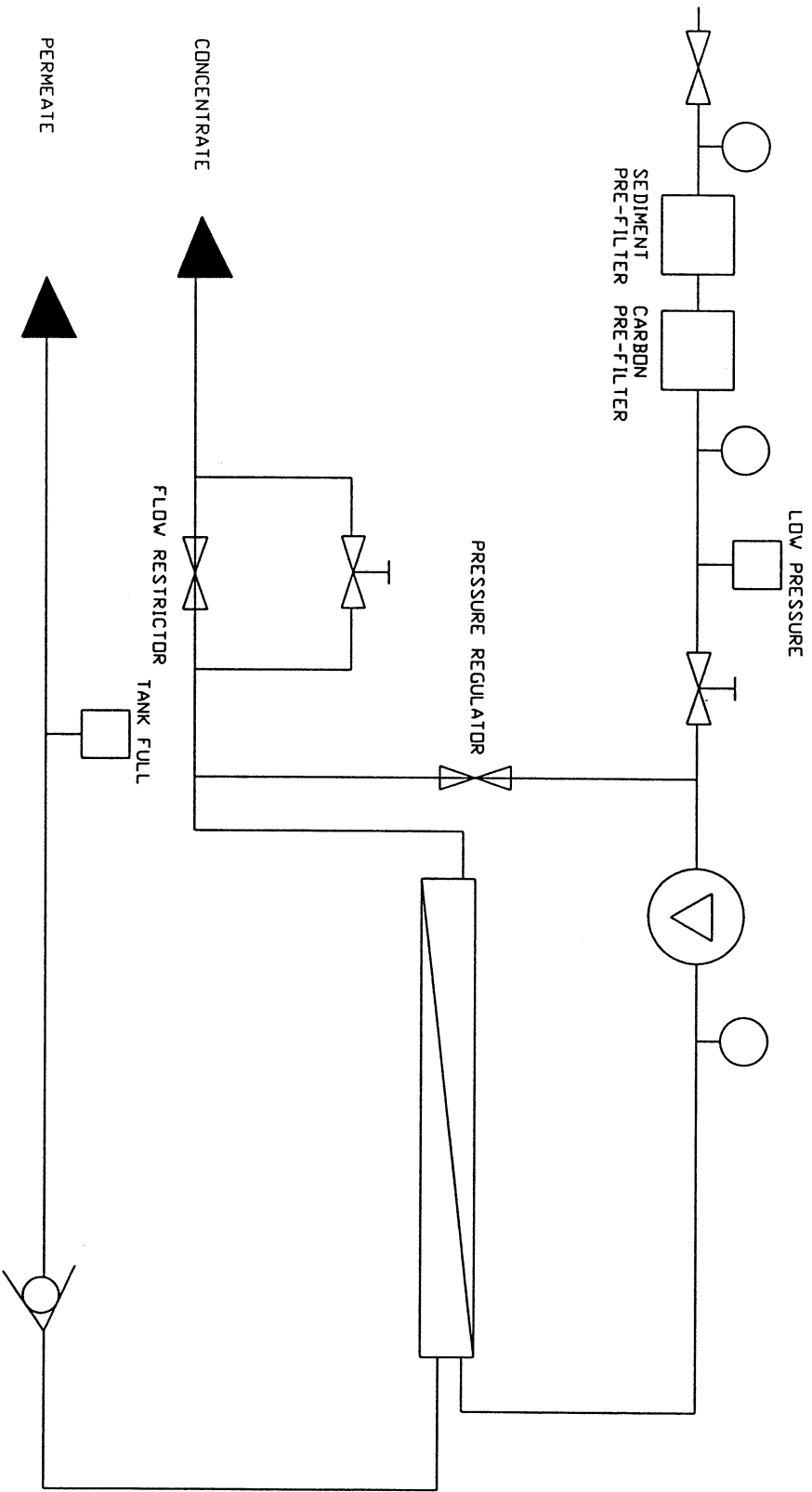







DESIGNED BY: T. HUGHES	TITLE: 150 GPD COMMERCIAL REVERSE OSMOSIS PIPING & INSTRUMENTATION				
DRAWN BY: J. NICHOLS					
CHECKED BY:	SIZE: ND _R -1070	SH. 1	DF. 1	SHEETS	REV.
DATE: 01/07/97	TOLERANCES:				
MATERIAL:	SCALE: NTS				



- LEGEND**
- PROCESS PUMP
 - PRESSURE GAUGE
 - ISOLATION VALVE
 - SOLENOID VALVE
 - NEEDLE VALVE
 - PRESSURE SWITCH
 - FLOW METER
 - PRE-FILTER
 - CHECK VALVE
 - CONDUCTIVITY PROBE

DESIGNED BY: T. HUGHES	TITLE: GPD COMMERCIAL REVERSE OSMOSIS 300 PIPING & INSTRUMENTATION					
DRAWN BY: J. NICHOLS						
CHECKED BY:						
DATE: 01/07/97						
MATERIAL:						
SCALE: NTS	SIZE:	NO. R-1071	SH. 1	OF 1	SHEETS	REV.
TOLERANCES:						

LEGEND

-  PROCESS PUMP
-  PRESSURE GAUGE
-  ISOLATION VALVE
-  SOLENOID VALVE
-  NEEDLE VALVE
-  PRESSURE SWITCH
-  FLOW METER
-  PRE-FILTER
-  CHECK VALVE
-  CONDUCTIVITY PROBE

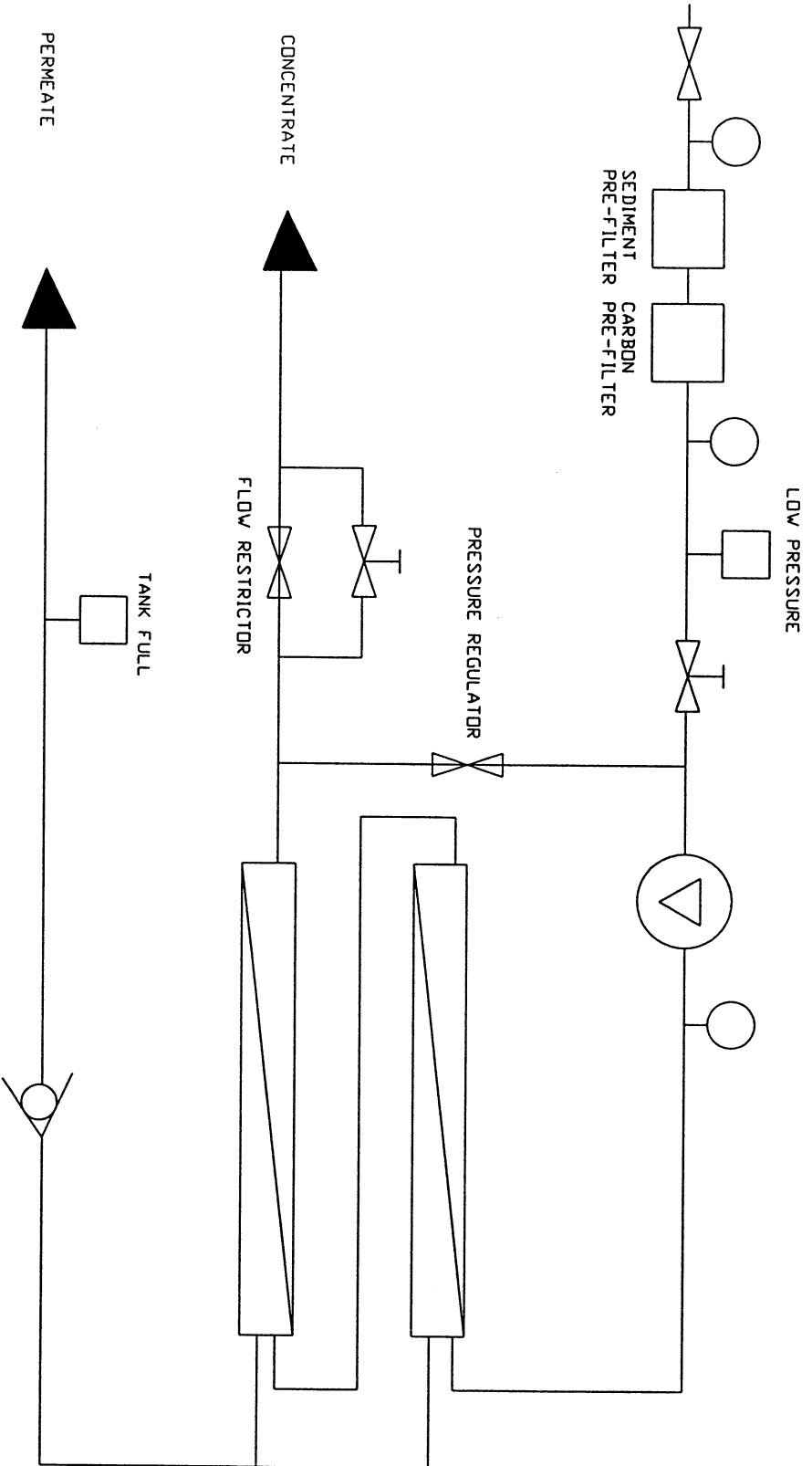

DESIGNED BY: T. HUGHES	TITLE: 450 GPD COMMERCIAL REVERSE OSMOSIS PIPING & INSTRUMENTATION		
DRAWN BY: J. NICHOLS			
CHECKED BY:	DATE: 01/07/97	SIZE:	ND. R-1069
MATERIAL:	SCALE: NTS	SH. 1	OF 1
TOLERANCES:		SHEETS	REV.

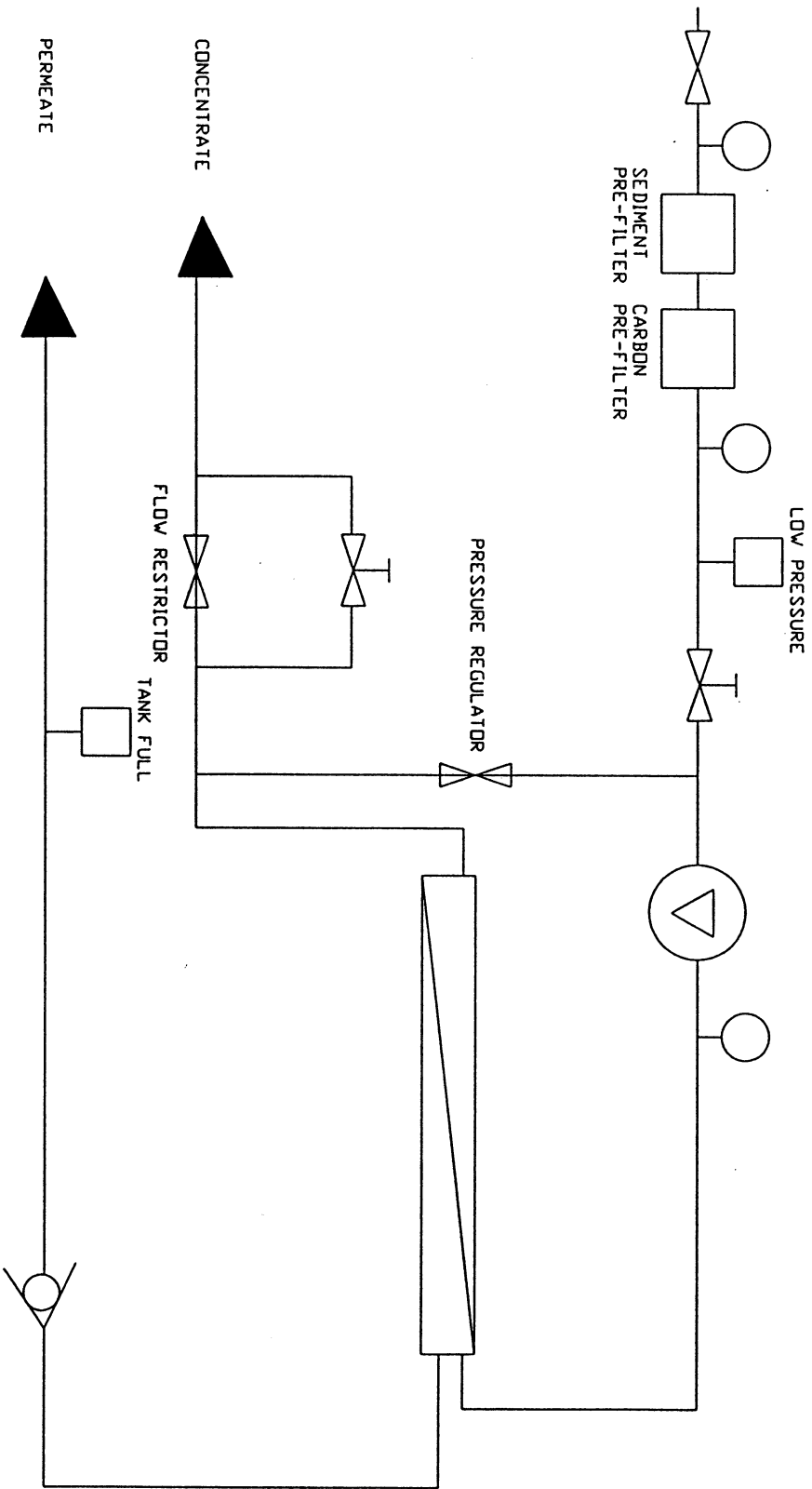

LEGEND

- PROCESS PUMP
- PRESSURE GAUGE
- ISOLATION VALVE
- SOLENOID VALVE
- NEEDLE VALVE
- PRESSURE SWITCH
- FLOW METER
- PRE-FILTER
- CHECK VALVE
- CONDUCTIVITY PROBE

DESIGNED BY: T. HUGHES	TITLE: 300 GPD COMMERCIAL REVERSE OSMOSIS PIPING & INSTRUMENTATION		
DRAWN BY: J. NICHOLS			
CHECKED BY:	DATE: 01/07/97	SIZE:	ND-R-1071 SH. 1 OF 1 SHEETS
MATERIAL:			REV.
SCALE: NTS			
TOLERANCES:			

- ### LEGEND
- PROCESS PUMP
 - PRESSURE GAUGE
 - ISOLATION VALVE
 - SOLENOID VALVE
 - NEEDLE VALVE
 - PRESSURE SWITCH
 - FLOW METER
 - PRE-FILTER
 - CHECK VALVE
 - CONDUCTIVITY PROBE

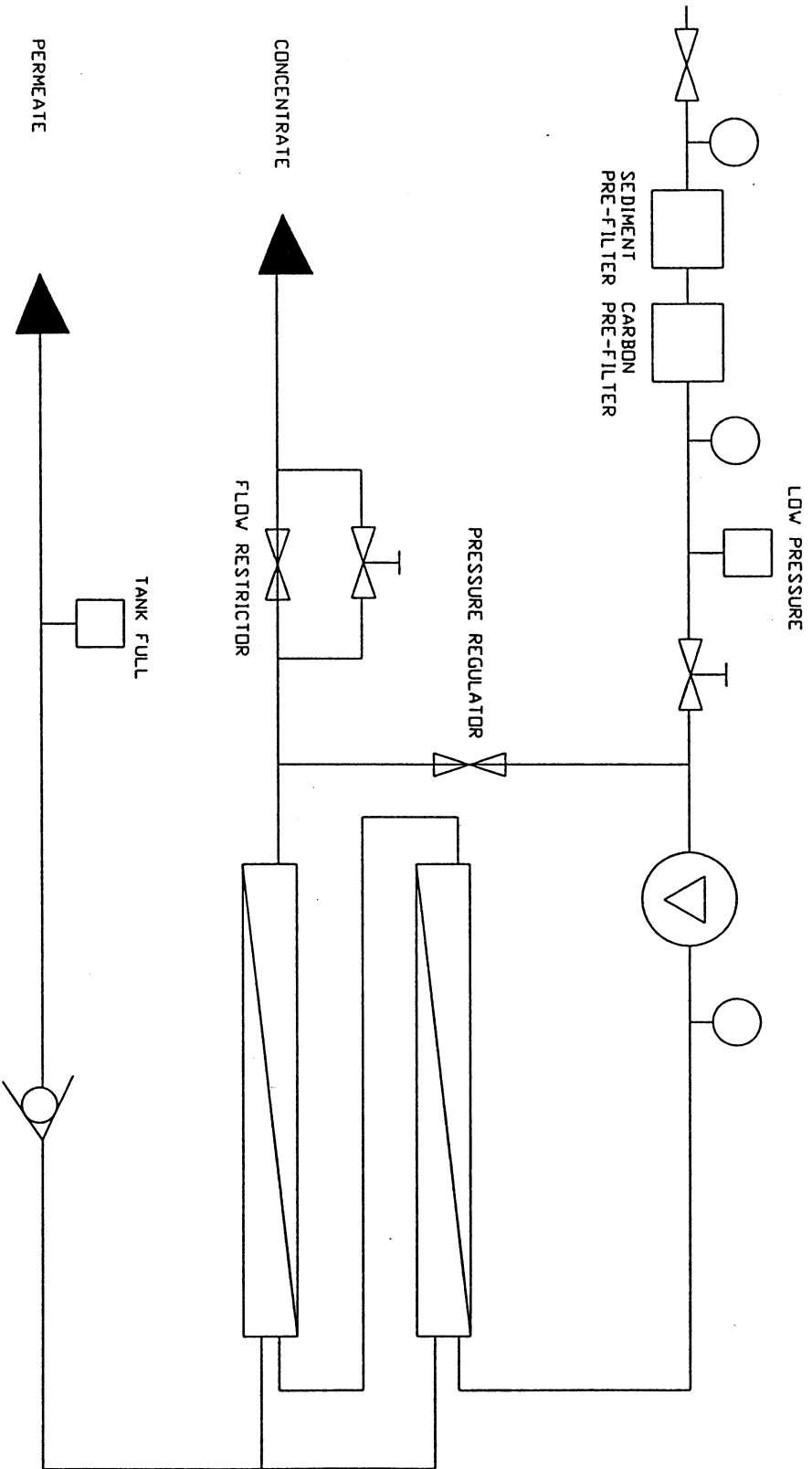

DESIGNED BY: T. HUGHES	TITLE: 450 GPD COMMERCIAL REVERSE OSMOSIS PIPING & INSTRUMENTATION					
DRAWN BY: J. NICHOLS						
CHECKED BY:						
DATE: 01/07/97	SIZE:	NO. R-1069	SH. 1	DF. 1	SHEETS	REV.
MATERIAL:						
SCALE: NTS						
TOLERANCES:						